

Model

# KGK JET CCS-R

Continuous Ink Jet Printer for Industrial Use

## Instruction Manual

Basic

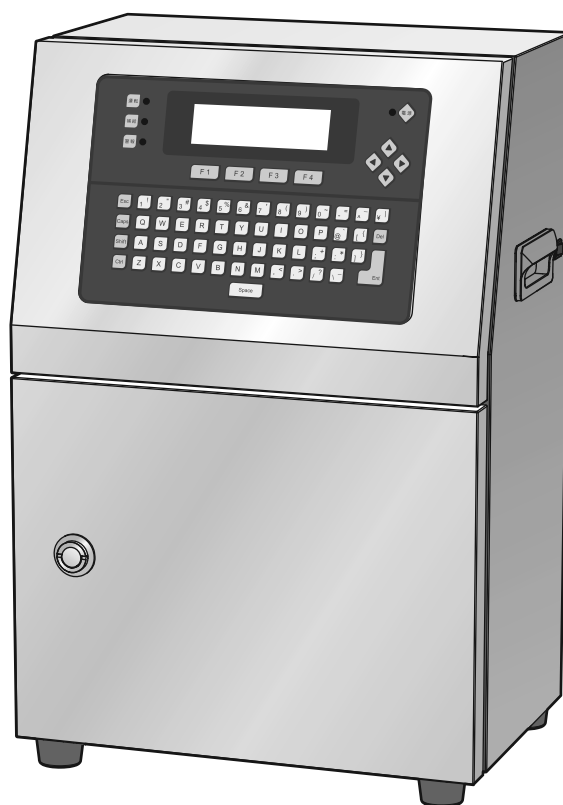

Thank you very much for purchasing this product.

Please make sure to read this manual thoroughly for correct operation.

Further, please store this manual in a location with easy access. This manual will be of use if you are unsure of how to operate the machine, or if a malfunction should occur.

**KGK** KGK Co., Ltd.

# Introduction

---

The KGKJET CCS-R continuous ink jet printer for industrial use is designed to enable a broad range of uses as a high-speed marking machine on various production lines.

Also, the appliance ensures no difficult maintenance work, which is required for existing ink jet printers, by completely eliminating nozzle clogging due to ink dry. Consequently, time and work for printing preparation has been drastically reduced.

## About this Manual

---

This manual is exclusive for the KGKJET CCS-R.

This manual is described for using other than JAPAN and CHINA.

This manual shall not be reproduced in part or in whole without our prior permission. Every effort has been made to prepare this manual. However, if you have any questions or find any errors, please contact us.

This manual is subject to change for improvement etc. without notice.

## Liabilities

---

We shall not be liable for any damage caused by fault, malfunction or defect of this product.

We shall not be liable for the mounting of consumables, options, or parts other than the parts recommended by our company.

Nor shall we be liable for any unauthorized remodeling of the equipment.

All company and product names in this manual are trademarks or registered trademarks of their respective owners.





In this manual, TM and (R) mark are not specified.

---

# Safety Precautions

Read the "Safety Precautions" thoroughly before use of this appliance and handle it correctly to achieve the best performance. This manual describes safety guidelines as follows to prevent bodily injury and property damage from occurring.

## Explanation of Symbols

 <b>Danger</b>	Disregarding this mark when handling may cause fatal or serious bodily injury.
 <b>Warning</b>	Disregarding this mark when handling may cause bodily injury or material damage.
 <b>Caution</b>	Disregarding this mark when handling may cause poor performance or breakdown of this product.
 Prohibition	This symbol describes "Prohibited" actions that must never be performed.
 edict	This symbol describes "Compulsory" actions that must be performed.

## Information Pertaining to Particular Dangers for Man

### **Danger**



Refrain from looking into printing head while the inkjet system is operating. Ink from printing head may go into your eyes.  
After eye contact, rinse opened eye for several minutes under running water and consult doctor. After swallowing, symptoms persist consult doctor.

## Installation Sites

Incorrect installation environment of appliance may cause an accident or fault. Be sure to read these precautions and install the appliance correctly.

Do not install the appliance in the following places. Doing so may cause fire, accident, malfunction of appliance, print defect, etc.

### **Danger**



**Enclosed or narrow spaces with poor ventilation etc., and sites where solvent vapor cumulates easily**  
There is a danger of solvent poisoning. There is also a danger of fire.

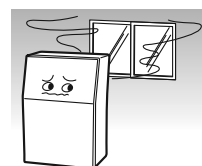

**! Danger**



**Place near source of fire**

There is a danger of fire. Use of fire within 10m around the appliance is strictly prohibited.

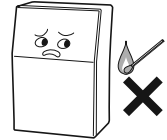

**Installation in places at high temperatures is prohibited.**

Do not install the appliance in places subject to direct sunlight or high temperatures for use. Doing so may cause fire.



**Dusty places**

Do not install the machine in dusty places for use. Troubles may occur in the internal circuits due to dust, resulting in fire.



**! Warning**



**Installation in places subject to oscillation or in unstable places.**

Do not install the machine in place where oscillation directly transmits to the machine or in unstable places such as wobbling place. The machine may drop to cause bodily injury.



**Plugging up the vent hole is prohibited.**

Do not plug up the vent hole. The temperatures may rise, resulting in fire, because inside heat is not released.



**Place with terrible noise**

You cannot hear alarm buzzer, etc., resulting in delay for response in emergency case.



**Place with much electromagnetic noise from other peripheral equipment.**

Welding works are strictly prohibited within 10 m around the machine. Do not bundle the power cord and other power lines together. Insulate the print head so that it does not contact a conveyer, etc. directly. There is a possibility of malfunction.



**Place with corrosive gas atmosphere such as acid.**



**Sites outside the ambient temperature range of 0 to 40 and relative humidity range of 10% to 80% RH**



**Use only 100VAC±10%, 50/60Hz power supply**



**Make sure to ground securely**

Use a D type ground.

---

## Caution



**Place with much electromagnetic noise from other peripheral equipment.**

Welding works are strictly prohibited within 10 m around the machine.  
There is a possibility of malfunction.



**Isolate the photoelectric sensor**

If the photoelectric sensor is made of metal case, use the plastic mounting parts to insulate from the conveyer, etc.



**Isolate the print head**

Insulate the print head so that it does not contact a conveyer, etc. directly.



**Do not bundle the power supply wires and other wires together**

---

## Power Supply

---

### Danger



**Use of power supply other than specified voltage is prohibited.**

Use only 100VAC $\pm$ 10%,50Hz/60Hz or 220VAC $\pm$ 10%,50Hz power supply.  
Do not use the power supply other than specified voltage.  
Doing so may cause fire or electrical shock.



**Prohibitions when handling the power supply cable**

Do not damage, alter, nor heat power cables, nor put heavy items on them.  
The power supply cables may be damaged to cause fire and electrical shock.

---

## Inspections

---

### Danger



**Only trained and qualified service personnel shall remove the covers on the frontal side and back side of the main body. It is dangerous because it contains many high-voltage areas in it.**



**The machine may be damaged by removing and installing power cords, communication cables and I/O cables with power ON. Follow the procedures described in this manual during installation, moving, opening the machine cover, or connecting the machine.**

■ **Connecting**

- 1** Turn OFF all appliances including an external connection sequencer, PC, etc.
- 2** Unplug the device from the outlet.
- 3** Connect the cable to the machine.
- 4** Plug in each appliance.
- 5** Turn ON the power switches of each appliance.

■ **Removal**

- 1** Turn OFF all appliances including an external connection sequencer, PC, etc.
- 2** Unplug the machine from the outlet.
- 3** Remove all cables connecting to this machine.

**In Case of Emergency**

---

 **Danger**



**If the machine emits smoke**

If the machine emits smoke and gives off a strange smell, turn off the power and plug off as soon as possible, and contact us. Continuous use may cause fire.



**If that foreign objects enter machine**

If foreign objects ( water, dust, etc. ) enter the machine, turn OFF the power and unplug from the outlet as soon as possible, and contact us. Continuous use may cause fire.

---

---

## Precautions for Handling

### Danger



**Use a container made of conductive material and connect it to ground, if, during test print or maintenance, print drops are collected in the container.**

Print drops are electrically charged in a very small amount. If print drops accumulate, without connecting the container to ground, the amount of electric charge can become so big to cause fire.

In normal situations, however, the print substrate moves on the container, hence there is no such a big amount of accumulation of electric charge to cause fire.

---

### Caution



**Perform test printing before use; otherwise it may lead to unsatisfactory printing or poor ink adhesion depending on the conditions of the target ( such as material properties, static charges, and the condensation or oil on the target ) or target feeding status ( such as a zig-zag movement and feed speed ) .**



**The combined use of this product and other equipment may prevent this product from delivering its full functions and/or performance, depending on the operating conditions or environment. Fully examine those points before adopting it.**



**When you change the printing-contents or printing-condition by UI-operation or communication-processing during printing, the gap of printing-position and no-printing are more likely to occur, because the load of CPU for control becomes higher.  
(When input the printing-order while making printing data. etc.)**

---

# Reading this Manual

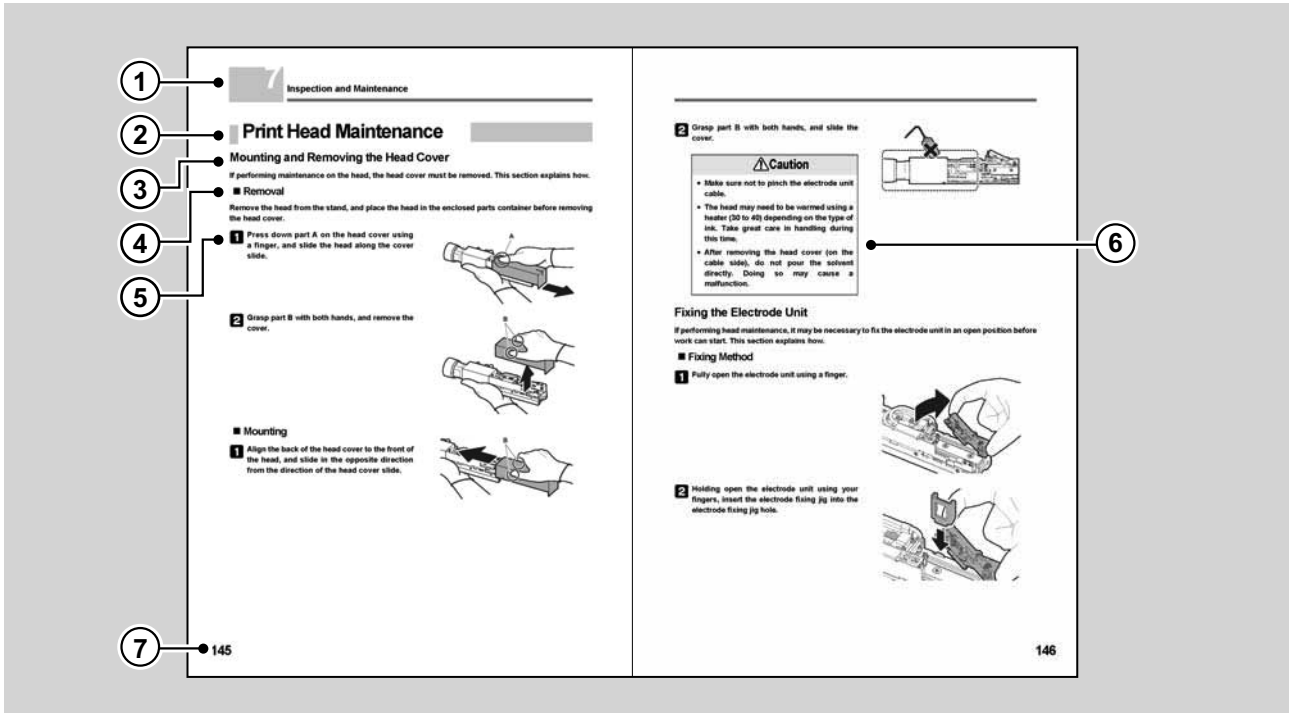

No.	Item	Explanation
	Chapter heading	
	Headline	
	Sub-headline	
	Bullet point	
	Operations and work procedure	Explains how to call function settings screens and the operations flow, etc.
	Supplement	Useful information such as operations advice and precautions, etc.
	Page	



# Contents

## **Introduction 1**

---

Safety Precautions	2
Explanation of Symbols	2
Information Pertaining to Particular Dangers for Man	2
Installation Sites	2
Power Supply	4
Inspections	4
In Case of Emergency	5
Precautions for Handling	6
Reading this Manual	7

## **Main Characteristics 17**

---

## **Preparations before Use 19**

---

Checking Package Contents	19
Product Configuration	22
Basic Configuration	22
Optional Configurations	23

## **Part Names 25**

---

CCS-R Main Unit	25
Appearance	25
Interior	26
Control Panel	27
Print Head	28
Interior Appearance	28

## **Basic Use 29**

---

Operation Flow	29
Turn ON the Power Supply	29
Operating the Head	30
Printing	30
Stopping the Head	30
Turning OFF the Power Supply	31

<b>Settings</b>	<b>32</b>
Setting the Printing of Number	32
Setting the Print Conditions	32
Setting the Print Data	34
<b>Creating Print Data</b>	<b>38</b>
Creation Flow	38
Selecting Message Numbers	39
Setting the Layout Conditions	39
Registering Fixed Characters	40
Changing Character Properties	44
Registering Blanks (blank data) at User-set Distances	44
Entering Characters Not on the Control Panel	45
Registering Numbering Characters	49
Registering Date Characters	50
Registering Barcode	52
Saving Message Numbers	54

## **Advanced Use 55**

---

<b>Character / Printing Calibration</b>	<b>55</b>
Characters Used	55
Character Height	55
Horizontal Dot Pitch	55
Density	55
Interspacing	55
Print Position	55
Print Speed	56
Print Style	56
Filter	57
Repeat Printing	60
Multiple Size Printing	60
Character Spacing Setting	60
<b>Calendar Module</b>	<b>61</b>
Calendar Characters	61
Calendar Character Replacement	66
Day of the Week Setting	67
PM Switchover Timing Setting	67
Setting the Method to Calculate Expiry Date Displays	67
Start of week number setting	64

# Contents

5

Numbering Module _____	68
Numbering Character Replacement _____	68
Changing the Current Numbering Value _____	68
Barcode Module _____	69
Printable Barcode _____	69
Setting Items of Each Code _____	72
Characters Registerable _____	73
About Code 128 _____	75
Barcode Module Details setting _____	75
Barcode Setting _____	77
Interval Module _____	78
User Fonts _____	78
Creation Flow _____	78
Selecting User Font Storage Numbers _____	78
Editing User Fonts _____	80
Entering Explanatory Text _____	85
Saving the Edited Contents _____	85
Managing Consumables _____	86
Operations Explanation _____	86
Settings Procedure _____	87
Other Functions _____	88
Speed Tracking Printing _____	88
Interval Operation _____	88
Tracking Function _____	88
Forced Printing _____	88
Operations Log Display _____	88
I/O Test _____	89
System Status Display _____	89
External I/O _____	89
I/O Signals _____	89
Communications _____	89

## Explanation of Display Screens 91

---

Screen Configuration Table _____	91
Screens Explanation _____	93
Main Menu _____	93
Unit Information _____	94
Unit Information [Detail] (Unit Test) _____	96
Editing _____	97
Select Message _____	98
Print Condition _____	99
Counter Value _____	101
Repeat Print Condition _____	102
Edit Module _____	103
Calendar Module Editing _____	105
Calendar Offset Editing _____	105
Numbering Module Editing _____	106
Barcode Module Editing _____	107
Barcode Module Details _____	107
Interval Module Editing _____	109
Edit Message (Message Selection) _____	110
Message Editing _____	111
Message Layout _____	112
Text Module Editing _____	113
Character Properties _____	113
Config _____	114
System Clock _____	115
Interval Running _____	116
Unit Config _____	118
CHG Detect Rectify _____	119
Interspacing Type _____	121
Head Heater Config _____	121
Encoder Config _____	122
Photo Sensor Monitoring _____	123
Transmit Config _____	124
I/O Output Condition _____	125
Priority Management _____	126
Calendar Config _____	127
Shift-code Config _____	128

# Contents

6

Operation Config _____	129
Level Config _____	130
Change Password _____	131
No. Date Renewal _____	132
Replace-character Selection _____	132
Replace-character Edition (1) _____	133
Replace-character Edition (2) _____	133
Barcode Config _____	134
Service _____	135
System Status _____	136
Work Log _____	136
History Code Reference _____	137
Unit Log _____	137
Measurement Log _____	138
Exp. Management (1) _____	139
Exp. Management (2) _____	139
Forced Print _____	140
Bleed Process _____	141
Forced Mixing _____	141
Recirculation Process _____	142
Draining Process _____	143
I/O Test _____	144
Head Parameter _____	145

## Inspection and Maintenance 147

---

Periodic Inspections _____	147
Daily Inspections _____	148
Checking Electrode Unit and Gutter Dirt _____	148
Checking the Remaining Ink and Solvent Amounts, and Waste liquid Amounts _____	149
Checking the Insulation Tape Inside the Head Cover	150
Weekly Inspections _____	151
Checking Ink Pressure _____	151
Check Sedimentation of Pigment Components in the Ink Tank _____	151
Monthly Inspections _____	152
Checking the Extractor Air Filter _____	152
Checking Service Life _____	153
Inspecting Under Harsh Conditions _____	154
Attention to Stopping Pigment Ink Unit _____	154

<b>Maintenance</b>	<b>155</b>
<b>Screens Used in Maintenance Work</b>	<b>156</b>
<b>Displaying the Screens</b>	<b>156</b>
<b>Unit Information Screen</b>	<b>158</b>
<b>Unit Test Screen</b>	<b>160</b>
<b>Print Head Maintenance</b>	<b>161</b>
<b>Mounting and Removing the Head Cover</b>	<b>161</b>
<b>Fixing the Electrode Unit</b>	<b>162</b>
<b>Cleaning the Electrode Unit</b>	<b>163</b>
<b>Cleaning the Gutter and the Ink Outlet</b>	<b>166</b>
<b>Cleaning the Nozzle</b>	<b>169</b>
<b>Adjusting the Ink Flow Direction</b>	<b>172</b>
<b>Adjusting the Fully-closed Nozzle Sealing</b>	<b>175</b>
<b>Replacing the Nozzle Gasket in the Nozzle Palette</b>	<b>179</b>
<b>Cleaning the Gutter Slide Unit</b>	<b>181</b>
<b>Checking and Adjusting the Clearance     between the Gutter and Nozzle</b>	<b>181</b>
<b>Replacing the Head Filter</b>	<b>182</b>
<b>Bleed Processing</b>	<b>185</b>
<b>Main Unit Maintenance</b>	<b>186</b>
<b>Replenishing Ink and Solvents</b>	<b>186</b>
<b>Disposal the Waste Liquid</b>	<b>188</b>
<b>Adjusting Ink Pressure</b>	<b>189</b>
<b>Adjusting Pump Pressure</b>	<b>186</b>
<b>Replacing the Ink Filter</b>	<b>192</b>
<b>Replacing the Large Circulation Filter</b>	<b>194</b>
<b>Cleaning and Replacing the Extractor Air Filter</b>	<b>196</b>
<b>Replacing the Air Pump</b>	<b>198</b>
<b>Replacing the Backup Battery</b>	<b>200</b>
<b>Replacing the Diaphragm unit</b>	<b>201</b>
<b>Long-term Storage of Pigment Ink Machine</b>	<b>204</b>
<b>Pigment Ink Machine Restart     after Long-term Storage</b>	<b>206</b>
<b>Dispose this Product</b>	<b>207</b>
<b>Periodic Replacement Parts</b>	<b>209</b>
<b>Recommended Spare Parts</b>	<b>210</b>

# Contents

8

## Troubleshooting 211

---

Q&A	211
Printing Trouble	211
Print Head Trouble	213
Main Unit Trouble	216
Display Panel Trouble	217
Error Codes and History Codes	219
Code Tables	219
History Code Details	221
Error Code Details	221
Warning Code Details	225
Alarm Code Details	228
Guarantee	235

9

## Specifications 237

---

General Specifications	237
Model-Dependent Specifications (CCS-R Specifications)	238
Characters and Print Specifications	239
Standard Fonts	239
Messages	239
Multi-Step Printing	240

10

## Appendix 247

---

Dimensional Drawing	247
Unit	247
Print Head	248
Position of Label	249
Unit	249
Print Head	252



# 1 Main Characteristics

The KGKJET CCS-R (hereinafter called the "CCS-R") is a continuous ink jet printer for industrial use that can print high-quality 26-dot characters.

The main features are described below.

## ■ Nozzle sealing system

The automatic nozzle sealing system seals the nozzle at the time of terminating operation and eliminates nozzle clogging caused by ink dry in the nozzle. It reduces solvent consumption, because automatic cleaning with solvent is not required at the time of startup and termination.

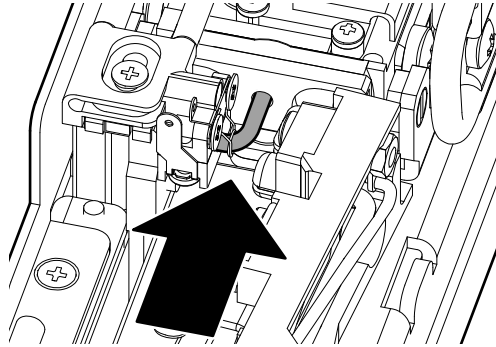

## ■ 26-dot high quality characters

Character height is up to 26 dots, font type is up to 24 x 24 dots and number of lines is up to 4.

For using in JAPAN and CHINA, JIS 1st and 2nd standard Chinese characters, Katakana, Hiragana, alphanumeric characters and symbols can be printed.

For using in other country, Latin and Arabic alphanumeric characters and symbols can be printed.

With standard built-in simplified Chinese fonts, it is suitable for international usage environment.

User characters can be registered.



---

## ■ Circulating ink automatically during operation stop

The machine has the interval mechanism to circulate the ink automatically during operation stop. Therefore there is no worry about nozzle clogging caused by ink dry during long holidays. The time to start and end the interval mechanism can be set arbitrarily using a timer.

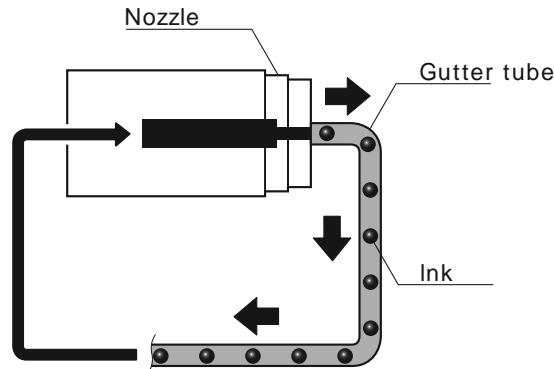

Nozzle sealed with the gutter

## ■ Design taking safety into consideration

The housing has the dust-proof and waterproof (IP24) mechanism and is designed taking safety, such as high voltage protection, into consideration.

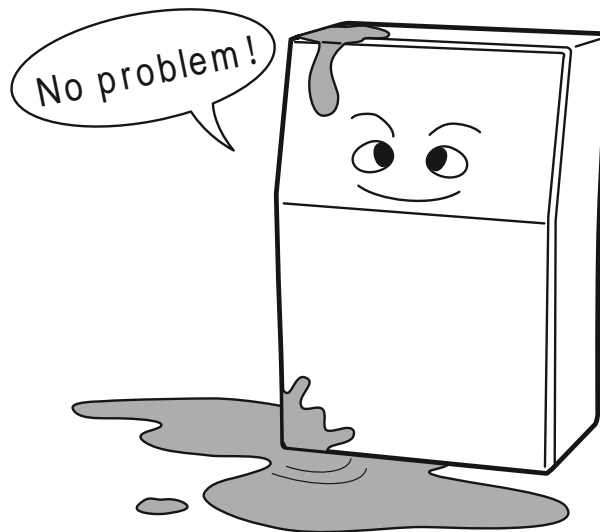

## ■ Responsive support

We have developed the hardware and software, therefore we can provide you with responsive customer support.

## ■ Pigment sedimentation prevention function by pump circulation (pigment ink machine only)

In the pigment ink machine, this function stirs the ink using pump circulation to prevent sedimentation of the pigment components in the ink. This function starts up when the power is turned on. In combination with the interval function, it eliminates problems due to sedimentation of pigments when the machine is idle for long periods.

# 2 Preparations before Use

## Checking Package Contents

One set of CCS-R includes the following:

### ■ CCS-R Main Unit

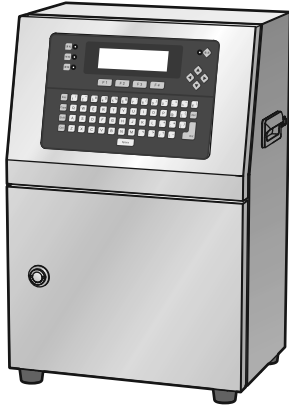

### ■ Instruction Manual

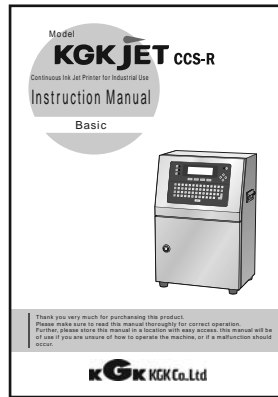

### ■ Maintenance Set

#### Washing bottle

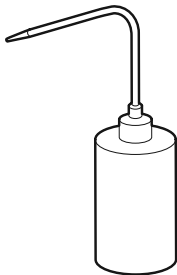

#### Blower



#### Safety goggles

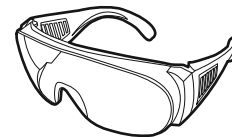

#### KayDry wiper



#### Container

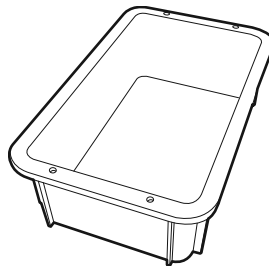

#### Phillips screwdrivers No. 0 / No. 1 / No. 2

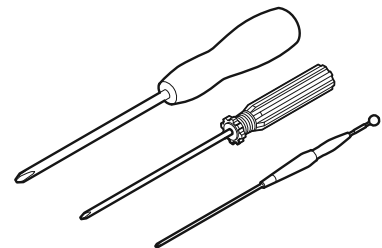

#### Slotted screwdriver 5.5 x 0.7

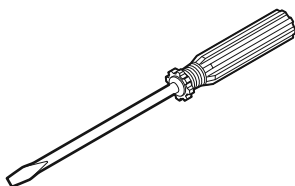

#### Wrench set



#### Clearance gauges (0.2mm / 0.3mm thick)

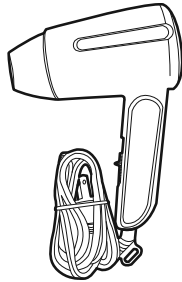
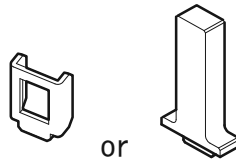
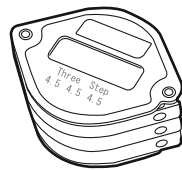

**Dryer****Electrode fixing jig****Tweezers****Stirrer  
(pigment ink machine only)****Magnifier**

### ■ Spare parts of replacement

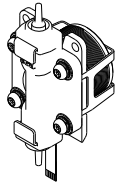
**Diaphragm unit or  
Diaphragm set  
(pigment ink only)**

or

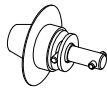

Diaphragm unit

Diaphragm set

Product Name	Remarks	Quantity
CCS-R Main Unit		
Instruction Manual		
Maintenance Set		
Washing bottle	Used with cleaning liquid.	1
Blower	For drying after cleaning the head.	1
Safety goggles		1
KayDry wiper	For cleaning the head.	1
Container		1
Phillips screwdrivers (No.0 / No.1 / No.2)		1 each
Slotted screwdrivers 5.5x0.7		1
Wrench set		1
Clearance gauges (0.2mm / 0.3mm thick)	For adjusting the clearance between gutter and nozzle.	1 each
Dryer	For drying after cleaning the head.	1
Electrode fixing jig	Use to fix the electrode in place.	1
Tweezers		1
Stirrer	Used to stir ink tank. (pigment ink machine only)	1
Magnifier		1

Product Name	Remarks	Quantity
Spare parts of replacement Diaphragm unit or Diaphragm set	Replacement parts for the circulation pump. (pigment ink only)	1

The following tools are not included in this maintenance set, but are very useful to have.

Product Name	Remarks
Hexagon nut spinner (5.5mm)	
Spanner set	
Glass beaker (100ml approx.)	
Ultrasonic cleaner	Used for cleaning clogged nozzles.
Torque driver (adjust to 1.4Nm)	Used when replacing the diaphragm set(CCS3000-MP-DPSET2). (pigment ink only)

# Product Configuration

## Basic Configuration

The standard product configuration comprises the CCS-R main unit, print head, and head cable.

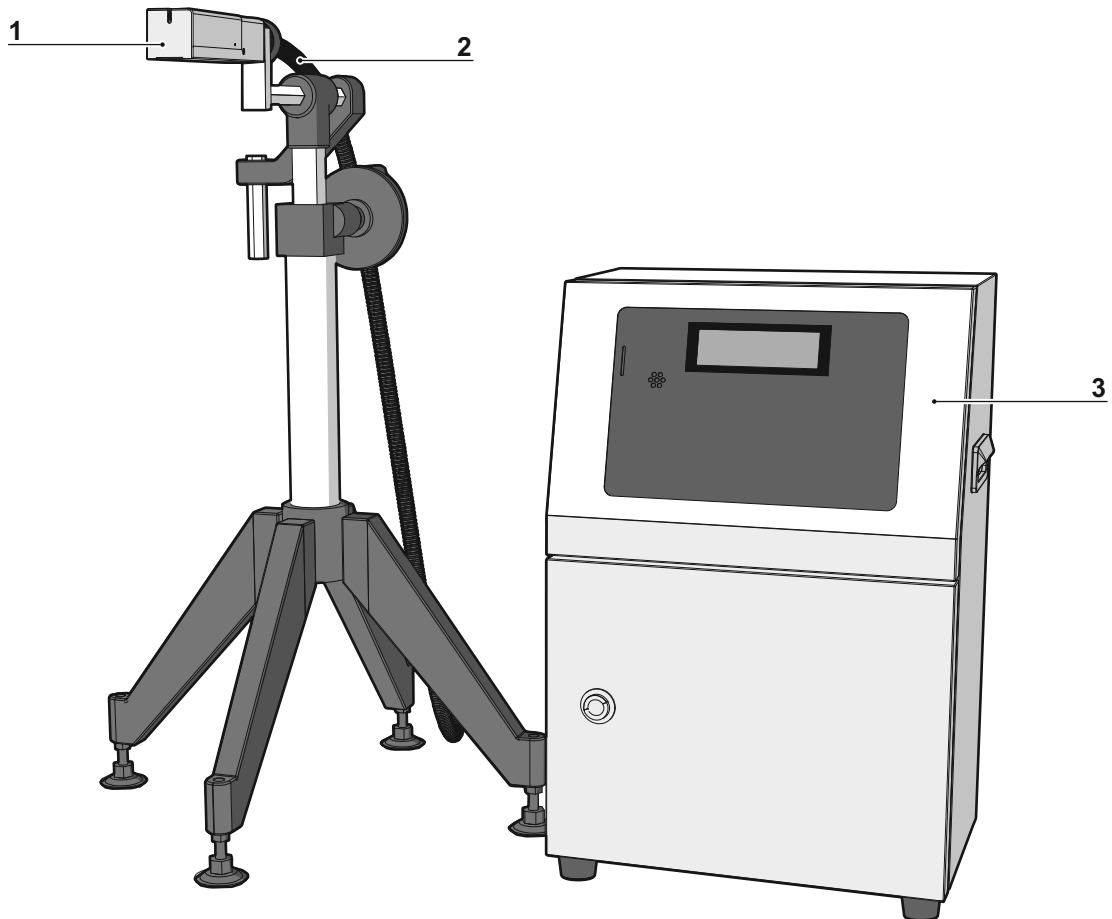

No.	Item	Explanation
1	Print head	Prints characters onto the current print target (i.e., the product to be printed).
2	Head cable	The cable to connect the print head and the ink unit.3.5m in length.
3	CCS-R Main Unit	Includes an ink circulation system to supply ink to the head, and an electronic circuit to operate and control the print head.

## Optional Configurations

Product Name	Remarks
Photoelectric sensor	Diffused reflection type and transmission type of photoelectric sensors are available. The available mounting methods are conveyer mounting and head mounting types.
Rotary encoder set	Enables printing at constant pitch on the conveyer even with fluctuating speeds.
Stand	Both side printing and top face printing directions are available. Both self-standing and mounted types are available.
Communications cable	Communications with a controller are possible using RS-232C cable.
Push button printing switch	Enables the printing to be checked manually.



# 3 Part Names

## CCS-R Main Unit

### Appearance

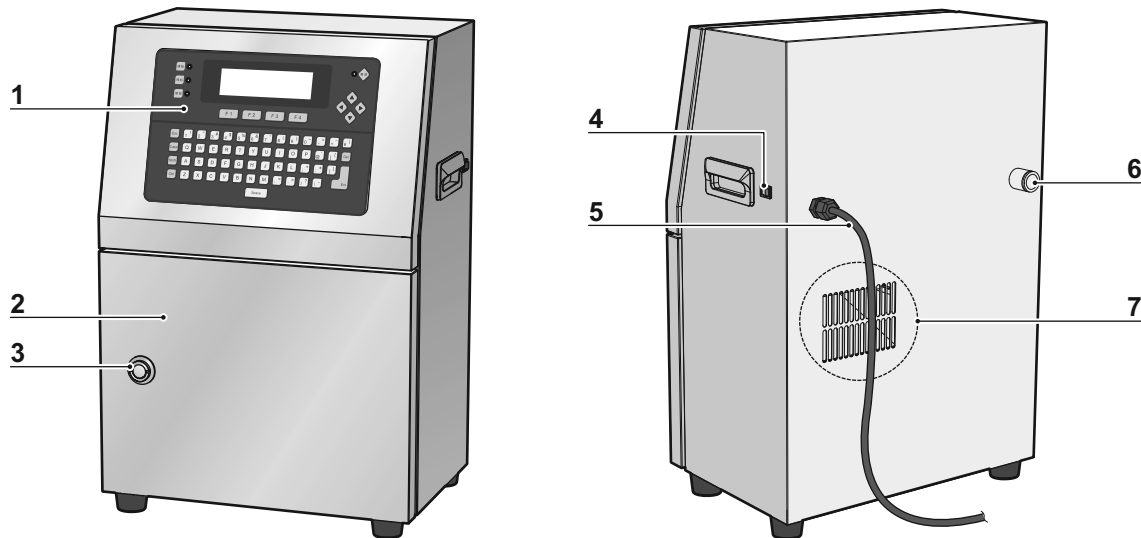

No.	Item	Explanation
1	Control Panel	Displays information on the LCD, and enables items to be selected and characters to be entered using the keyboard.
2	Front Cover	
3	Knob	Turn to open the front cover.
4	Main Power Supply	Turns ON and OFF the main power supply for the CCS-R.
5	Power Cord	
6	Head Cable	Cable to connect the print head with CCS-R main unit. Length is 3.5 m.
7	Air Vent	Air intake for air ventilation and cooling. Do not block off the air vent.

# Interior

Standard unit

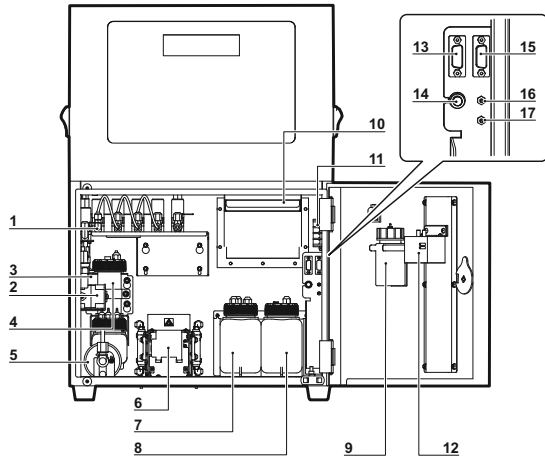

Pigment ink unit

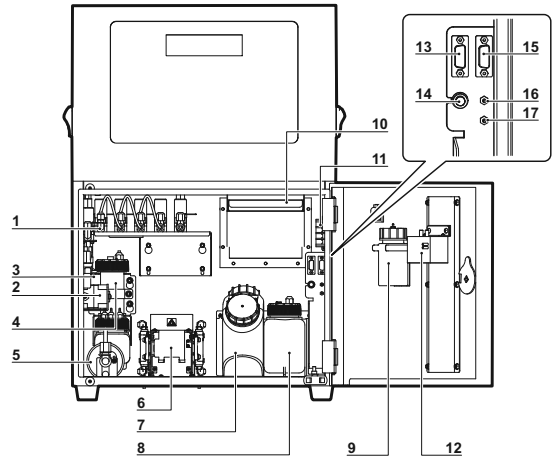

No.	Item	Explanation
1	Valve Unit	Controls the flow of ink.
2	Regulator	Controls the ink pressure.
3	Pressure Sensor	Measures the ink pressure.
4	Main Tank Unit	Measures and adjusts ink viscosity.
5	Filter	Filters impurities from the ink.
6	Ink Pump	Circulates and recovers the ink.
7	Ink Tank Unit	Stores the ink for later use.
8	Solvent Tank Unit	Stores the solvent for later use.
9	Condensate Tank Unit	Stores the waste liquid.
10	Dust Filter	Filters dust during external air intake.
11	Terminal Block	Outputs I/O signals.
12	Air Pump	Sends fresh air to the print head.
13	RS-232C	Used when communicating to upper computer.
14	Photoelectric sensor	Connects photoelectric sensor.
15	Rotary encoder	Connects rotary encoder.
16	Purge	Purge outlet to head.
17	Drain	Condensate tank drain.

## Control Panel



No.	Item	Explanation
1	Operation Lamp	Flashes during warmup, and then is lit green when printing is enabled.
2	Supply Lamp	Lit orange when either the remaining ink or solvent is low.
3	Warning Lamp	Lit red if a malfunction occurs.
4	Function Keys	Performs the corresponding process when <b>F1</b> to <b>F4</b> is displayed on screen.
5	Power Supply Switch	Turns ON and OFF the power supply. Lit green while the power supply is ON.
6	LCD	Displays information. Use <b>&lt;</b> or <b>&gt;</b> to adjust contrast.
7	Moving Keys	Moves the cursor in the selected direction.
8	Input Keys	Use to enter the settings and print details, and to determine items.

# Print Head

## Interior Appearance

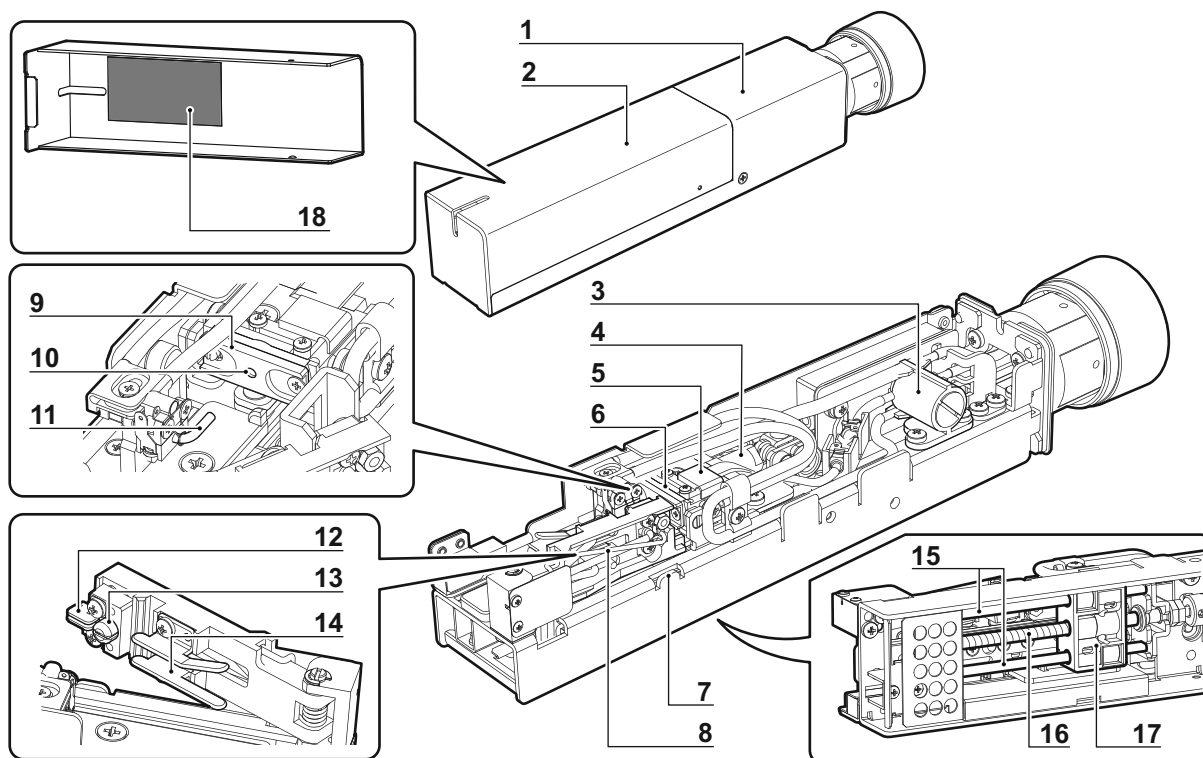

No.	Item	Explanation
1	Print Head	
2	Print Head Cover	
3	Ink Filter Case	Filters impurities from the ink circulating through the print head.
4	Piezo	
5	Heater	Warms the ink if environmental temperature is low.
6	Gun	
7	Electrode Fixing Jig	The hole for inserting the electrode fixing jig.
8	Electrode Unit	
9	Nozzle Plate	Fixes the nozzle gasket for the nozzle sealing.
10	Nozzle	Sprays pressurized ink.
11	Gutter	Recovers the ink.
12	Charge Electrode	Charges to a negative voltage according to the amount of deflection of the ink particles.
13	Detector Electrode	Detects whether the ink particles are charged.
14	Deflection Electrode	Applies high voltage to deflect the ink particles.
15	Slide Shaft	
16	Slide Screw	
17	Slide Unit	
18	Insulation tape	Prevents leakage of high voltage from deflection electrodes to the printhead cover.

# 4 Basic Use

## Operation Flow

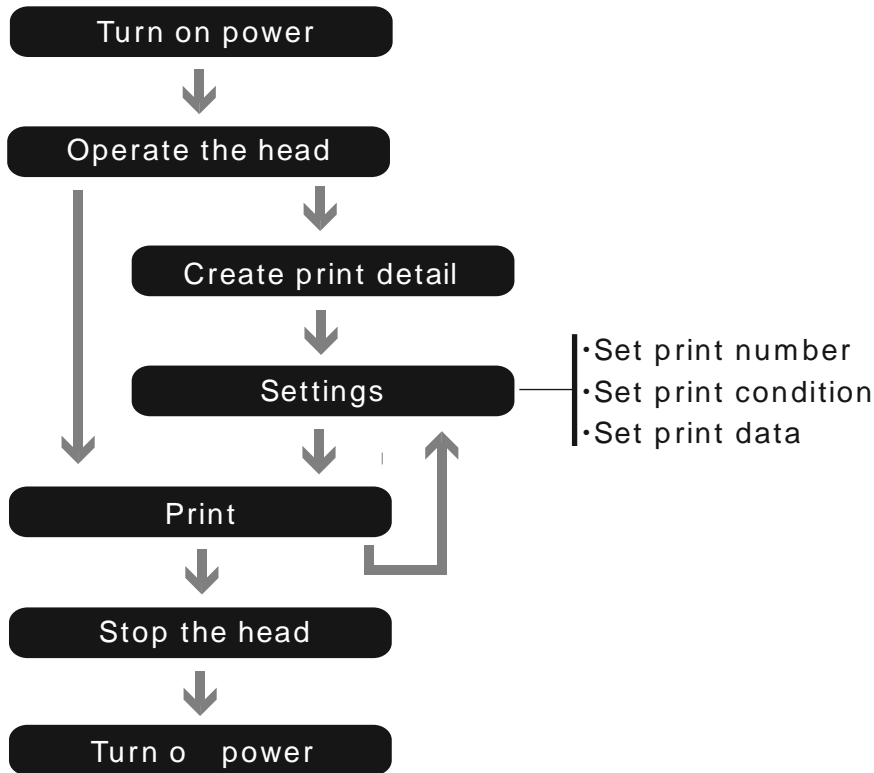

## Turn ON the Power Supply

- 1** Press and hold the "Power" key in the top right of the control panel for approx. 1 second.

### Reference

If the device does not start even when the "Power" key is pressed, turn ON the breaker on the right side of the unit.

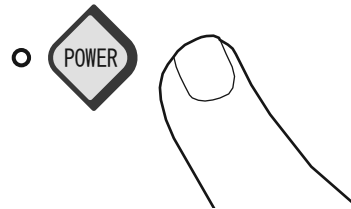

- 2** The unit will take approx. 1 minute to complete startup after the power supply has been turned ON, so please wait.
- 3** When the unit startup has been completed, the "Main Menu" will be displayed.

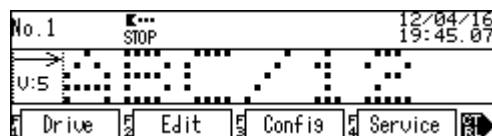

## Operating the Head

- 1 Press the **F1** (Drive) key in the "Main Menu".

The icon that displays the head status will change from STOP to RUN, and the **F1** display will change (from Drive to Stop).

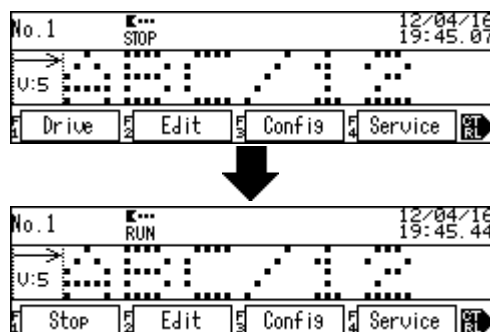

- 2 The operations LED on the top left of the control panel will start to flash.  
(This shows that the head is getting ready.)  
When the LED stops flashing and remains constantly lit, printing can be performed.

## Printing

- 1 Printing is performed by entering external print commands (from a photoelectric sensor).

### Reference

The operation LED also flashes during printing.

## Stopping the Head

- 1 Press the **F1** (Stop) key in the "Main Menu".

The icon that displays the head status will change from RUN to STOP, and the **F1** display will change (from Stop to Drive).

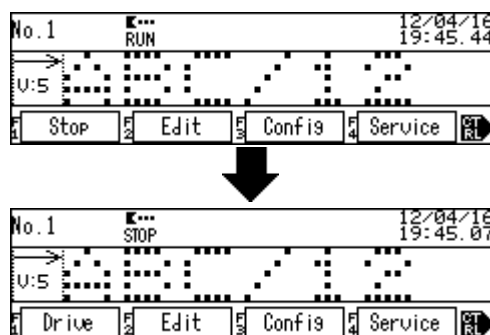



## Turning OFF the Power Supply

- 1** Press the  key in the "Main Menu" to change the function key allocations.

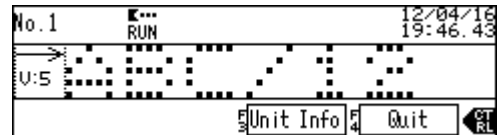
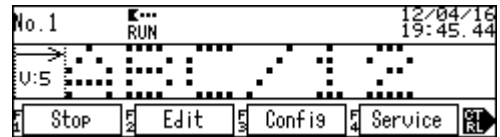
Press the  (Quit) key.



- 2** A check message will be displayed, so press the   key, select "YES", and then press the  key.



### Reference

- Even if the head is operating, the power supply will turn OFF after the nozzle has been capped.  
(If printing, the power supply will be turned OFF after the current character has finished printing. Take care if the rotary encoder is being used.)
- Press and hold the "POWER" key on the top right of the control panel for approx. 1 second to turn OFF the power supply.  
(No check message will be displayed.)

# Settings

## Setting the Printing of Number

**1** Press the **F2** (Edit) key in the "Main Menu".

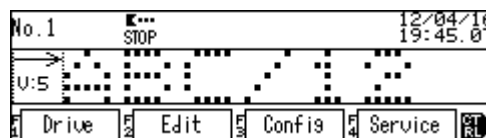

**2** The edit functions will be displayed. Press the **▲▼** keys and select "Select Message", and then press the **Ent** key.

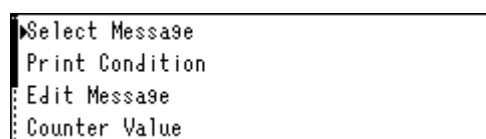

**3** The message selection screen will be displayed. Press the **▲▼** key corresponding to the number of the message to be printed.

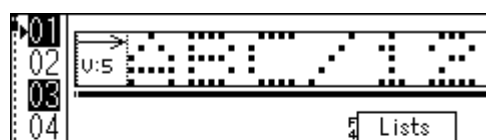

When the selection has been completed, press the **Ent** key.



**4** A check message will be displayed, so press the **◀▶** key, select "YES", and then press the **Ent** key.



## Setting the Print Conditions

**1** Press the **F2** (Edit) key in the "Main Menu".

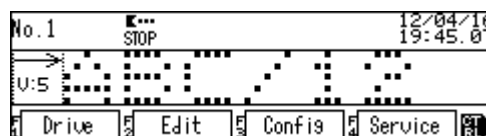



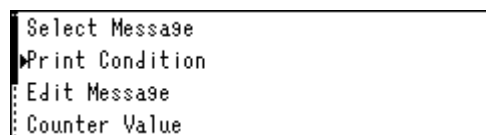

**2** The edit functions will be displayed, so press the **▲▼** keys to select "Print Condition", and then press the **Ent** key.





### 3 Edit the print conditions for the required items.

Press the   keys to select the item to be edited.

Press the  to  keys or the   key to change the values and selected items.

#### Reference

Select the value input type for the edit items (i.e., change the values by pressing the  to  keys). The entry range will be displayed in the bottom right of the screen.

```
Char. Height [ 17 ]
Horizontal Pitch [ 0.60 ]
Density [ 1 ]
Default 2 COPY 3 Sel M9. 4
```



```
Char. Height [ 17 ]
Horizontal Pitch [ 0.60 ]
Density [ 1 ]
Default 2 COPY 3 Sel M9. 4
```



```
Char. Height [ 17 ]
Horizontal Pitch [ 0.60 ]
Density [ 2 ]
Default 2 COPY 3 Sel M9. 4
```

### 4 When the editing has been completed, press the key.

### 5 A check message will be displayed, so press the key, select "YES", and then press the key.

```
Char. Height 17
Horizontal Pitch 0.60
Density 2
Save data? < YES
```

## ■ Edit Items

Edit Items	Explanation	Settings Range
Char. Height	Adjusts the size of the top/bottom orientation of the characters.	1 to 29
Horizontal Pitch	Sets the pitch between adjoining dots along the character width. Used to determine the character width.	0.10 to 10.00 [mm]
Density	Density can be increased by overprinting once again from the top characters that have already been printed.	1 to 4
Interspacing	Used to improve the print quality. The greater the number, the better the quality. * Can be edited only when "Manual" has been selected for "Interspacing type settings". When "Auto" has been selected, set the optimum "interspacing" from other settings. And display "interspacing" with a decimal convenience because a change of "interspacing" makes it plain.	0 to 15 ("Manual") 0.0 to 15.0 ("Auto")
Prt. Position	Sets the distance from after the print command has been entered (photoelectric sensor) to the start of printing.	0.0 to 13107.1 [mm]
Prt. Speed	By setting the conveyer speed beforehand, the details of the items set by the distance such as print position and horizontal dot pitch, etc., are correctly reflected in the print results. * When using the rotary encoder, enter the maximum speed when the conveyer is operating.	1.0 to 500.0 [m/min.]



Edit Items	Explanation	Settings Range
Prt. Direction	Sets whether to print the printing information from the start (forwards) or from the end (back).	Forward / Back
Prt. Orientation	Reflects the top and bottom orientation of the characters.	Normal / Down
OFF Filter	Set to prevent misoperation due to print command chattering. After printing has been completed, prevents print commands from being received between the set distance. * Set to 0.0 if not in use.	0.0 to 13107.1 [mm]
ON Filter	Set to prevent misoperation due to print command chattering. Waits only for the set distance after the print command has been received, and then checks the print command again. If the print command is ON, printing is performed, and if the print command is OFF, printing is not performed. * Set to 0.0 if not in use.	0.0 to 13107.1 [mm]

## Setting the Print Data

This section explains the procedure for changing, for example, the contents of message from "ABC/12" to "123/12".

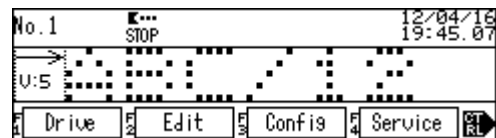

**1** Press the  (Edit) key in the "Main Menu".

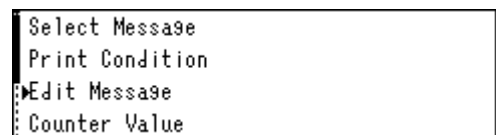

**2** The edit functions will be displayed, so press the   keys and select "Edit Message", and then press the  key.



**3** The message selection screen will be displayed.

Press the   keys corresponding to the number of the message to be edited.

(When the screen is first displayed, the number of the message currently being printed is selected.)



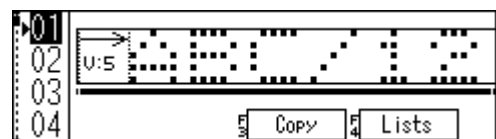





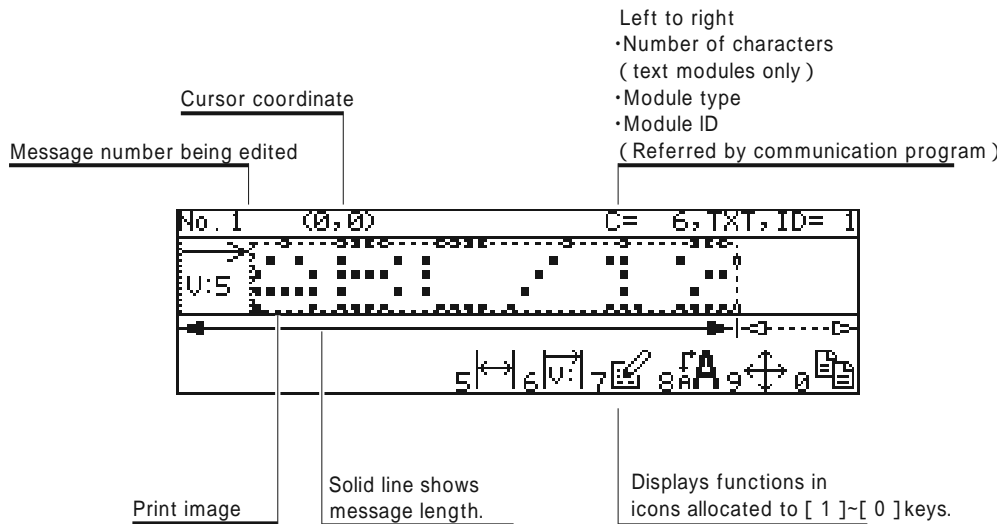





Press the  key to start editing.



- 4** When the message editing screen has been displayed, move the cursor to the module to be changed (in units of print data), and select the module (enclosed in the dotted lines).

Once selected, press the  key.



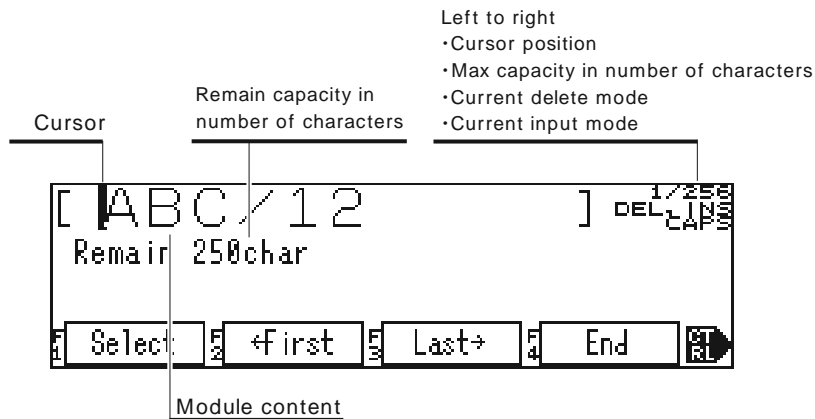

Key	Explanation
	Moves the cursor. * Press  at the same time to make big movements.
	Deletes a selected data ( module and layout ) .
	Terminates the editing.
	Creates a new text module (printing of fixed data).
	Inserts a new calendar module (printing of date/time).
	Inserts a new numbering module (printing of number).
	Inserts a new barcode module (printing of barcode).
	Inserts interval module (printing of space).
	Creates a new layout.
	Edits existing data (modules and layouts).
	Changes the properties of existing text, calendars, numbering, and barcode modules.
	Moves the existing data position.
	Copies the module data to the user-defined position.

## 5 Edits the module details.



Key	Explanation
	Moves the cursor.
	Back space (Deletes the character immediately before the cursor.) Alternatively, deletes the character at the cursor position.
	Turns ON and OFF the Caps Lock. (i.e., the mode for entering capital letters when the [A] to [Z] keys are pressed.)
(Character keys)	Enters characters. Press the  key at the same time to enter either English capital letters or key symbols displayed in the top right.
	Returns to the previous screen.
(Select)	Selects and enters characters not on the control panel. (Change "select character mode" and "direct input mode")
(<First)	Moves the cursor position to the start.
(Last>)	Moves the cursor position to the end.
(End)	Terminates the inputs.
	Switches the display between the function key above and the function key below.
(DEL/BS)	Switches processing (delete mode) when the  has been pressed. The current delete mode is displayed in the top right of the screen.
(OVW/INS)	Switches the processing (entry mode) when a character has been entered. The current entry mode is displayed in the top right of the screen. <ul style="list-style-type: none"> <li>• OVW : Overwrites the character to the cursor position when a character is entered.</li> <li>• INS : Inserts one character at the cursor position when a character is entered.</li> </ul>

- 6** Press the   keys to move the cursor to immediately before (i.e., to the right of) the character to be deleted.

Press the  key to delete the unnecessary character.

Enter the new characters.

#### Reference

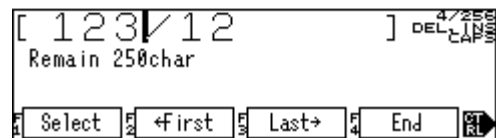
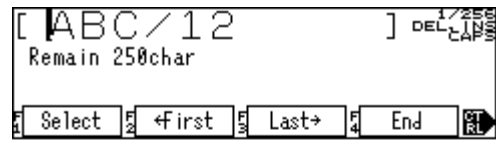

If entering characters that are not on the control panel, press the  (Select) key and select the desired characters.

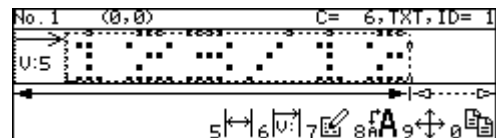

- 7** When editing has been completed, press the  (End) key.

- 8** The message edit screen will be displayed. Press the  key to finish editing the message.



- 9** A check message will be displayed once again, so press the   keys to select "Yes" and then press the  key.



This completes changes to the print data.

# Creating Print Data

## Creation Flow

Print data are created using the following flow.



This section explains how to register the following data as an example.

Message No.: 02

Print data:

NET. 1Kg

Number of scan dots : 16  
Font size : 16x12  
Character spacing : 1

Used by 08.04.05  
LOT Nr... 01234567

Number of scan dots : 20  
Font size : 9x7  
Character spacing : 1  
\* "0 8.0 4.0 5" date character,  
"0 1 2 3 4 5 6 7" numbering character

Interval (blank) : 45mm



Barcode type:ITF  
Height:17  
Bearer bar:Yes  
OCR:Yes

## Selecting Message Numbers

**1** Press the **F2** (Edit) key in the "Main Menu".

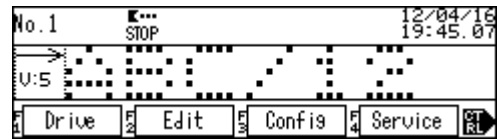

**2** The edit functions will be displayed, so press the **▲▼** keys to select "Edit Message" and then press the **Ent** key.

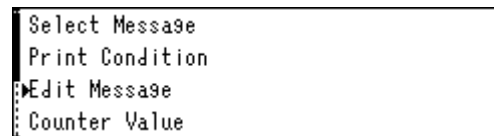

**3** The message selection screen will be displayed. Press the **▲▼** keys, and select No."02" as the location (message number) to which to save the print data.

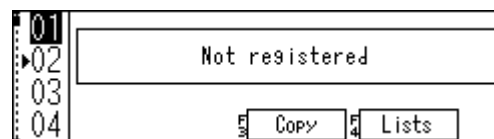

Press the **Ent** key to start editing.

## Setting the Layout Conditions

**1** The layout edit screen will be displayed, so edit the following conditions. When editing has been completed, press the **Ent** key.

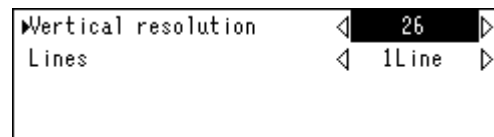

- Vertical: 16 dots
- Lines: 1

Item	Explanation	Selection Item Entry Range
Vertical resolution	Describes the vertical resolution. The greater the value the more detailed and large characters can be used, but this option cannot be used with fast print speeds, and print quality may be poor.	26, 24, 22, 20, 16, 15, 12, 11, 10, 9, 7, and 5 dots
Lines	Sets the number of vertical print lines. If "free" is selected, the character positions can be distributed freely.	1 to 4 lines and free

Note:As for 11 and 15 dots of the vertical resolution, needs DSP version D2-12-00 later.

Note:The relationship between the number of vertical dots and the number of print lines, which are layout edit items are described in the following diagrams.

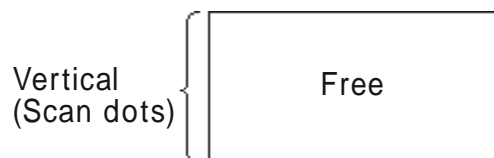
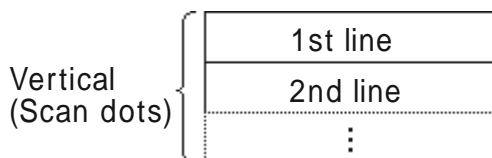

Number of scan dots: 20 dots, No. of print lines: In the case of one line.

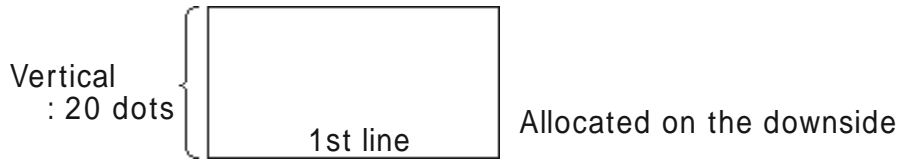

Number of scan dots: 20 dots, No. of print lines: In the case of two lines.

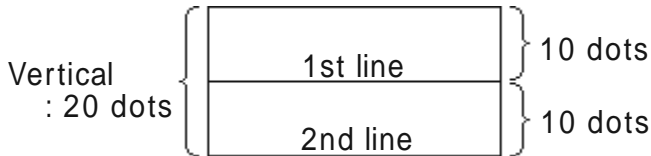

## Registering Fixed Characters

- The message edit screen will be displayed. There is no need to change the character positions on this occasion, so just press the A key.

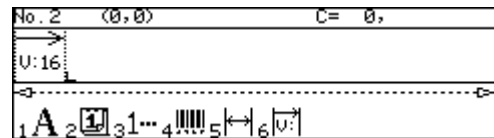

### ■ The Message Edit Screen

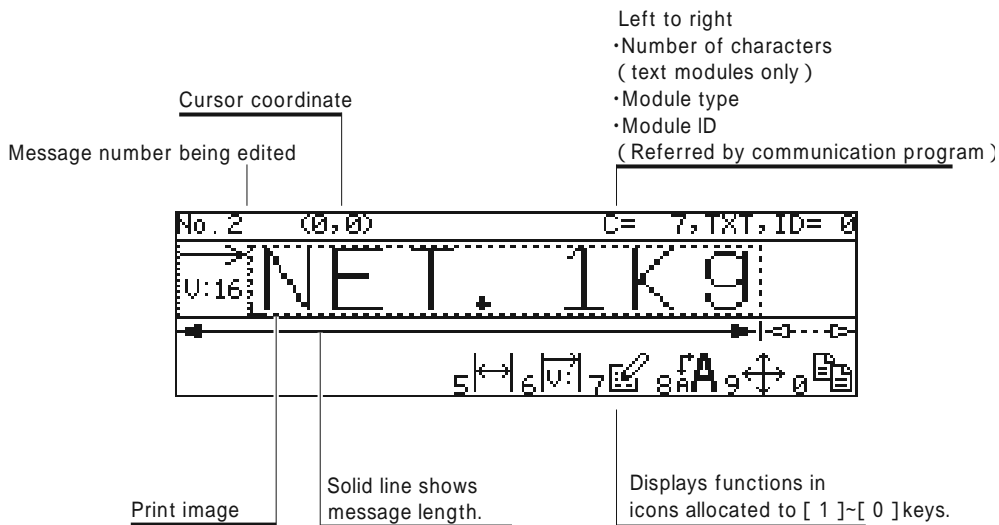

Key	Explanation
	Moves the cursor. * Press the  key at the same time to make big movements.
	Deletes a selected data ( module and layout ) .
	Terminates the editing.
A	Creates a new text module (printing of fixed data).
	Inserts a new calendar module (printing of date/time).

Key	Explanation
3 # 1...	Inserts a new numbering module (printing of number).
4 \$	Inserts a new barcode module (printing of barcode).
5 %	Inserts interval module (printing of space).
6 &	Creates a new layout.
7	Edits existing data (modules and layouts).
8 (	Changes the properties of existing text, calendars, and numbering modules.
9 )	Moves the existing data position.
0 ~	Sends the module copy data to the user-defined position.

### Module Types

Display	Explanation
TXT	Displays the text module.
CAL	Displays the calendar module.
NUM	Displays the numbering module.
BAR	Displays the barcode module.
INT	Displays the interval module.

### Reference

#### Message Editing Limits

- The maximum number of modules that can be registered to one message is 32.
- The maximum number of characters (text module characters only) is 512.
- The maximum number of characters that can be registered to a text module is 256.
- If editing messages using the control panel, modules cannot be allocated to overlap.

- 1** Enter by pressing "NET.1Kg" and the "CHAR" keys on the control panel. Hold down the key while typing to enter small letters.

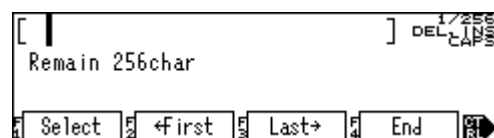

- 2** When editing has been completed, press the (End) key.





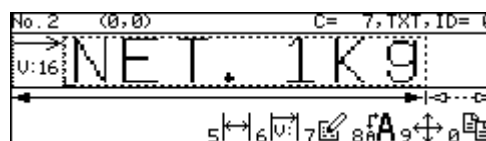

**3** This completes the "NET.1Kg" entry.

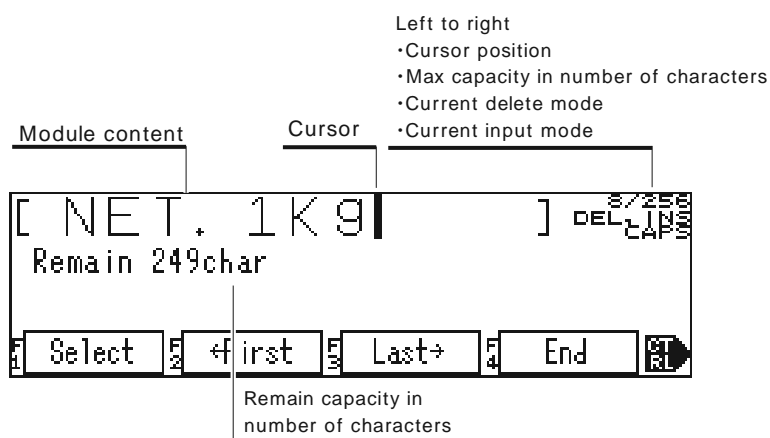

## ■ Character Entry Screen





Key	Explanation
	Moves the cursor.
	Back space (Deletes the character immediately before the cursor.) Alternatively, deletes the character at the cursor position.
	Turns ON and OFF the Caps Lock. (i.e., the mode for entering capital letters when the [A] to [Z] keys are pressed.)
(Character keys)	Enters characters. Press the  key at the same time to enter either English capital letters or key symbols displayed in the top right.
	Returns to the previous screen.
(Select)	Selects and enters characters not on the control panel. (Change "select character mode" and "direct input mode")
(Offset)	Displayed only when editing calendar modules. Used to enter the offset amount (i.e., the difference between the system clock and the print time).
(Code Type)	Displayed only when editing barcode modules. Change barcode type to be displayed.
(<First)	Moves the cursor position to the start.
(Last>)	Moves the cursor position to the end.
(Detail)	Displayed only when editing barcode modules. Set barcode module details.

Key	Explanation
 (End)	Terminates the inputs.
	Switches the display between the function key above and the function key below.
 (DEL/BS)	Switches processing (delete mode) when the  has been pressed. The current delete mode is displayed in the top right of the screen.
 (OVW/INS)	Switches the processing (entry mode) when a character has been entered. The current entry mode is displayed in the top right of the screen. <ul style="list-style-type: none"><li>• OVW : Overwrites one character to the cursor position when a character is entered.</li><li>• INS : Inserts one character at the cursor position when a character is entered.</li></ul>

## Changing Character Properties

- 1 The font size (character size) and character spacing (distance between characters), etc., of characters that have already been entered can be changed.

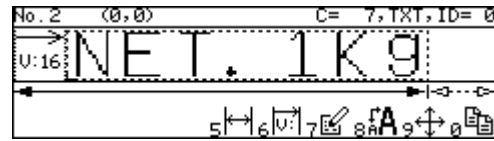

Use the cursor to select the details to be changed, and then press the   key.

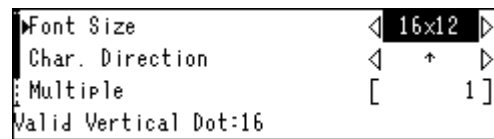

- 2 The character properties edit screen will be displayed, so edit the following conditions. When editing has been completed, press the  key.

- Font size: 16 × 12
- Char. Direction: (unchanged)
- Multiple: 1 (unchanged)
- Char. Space: 1



- 3 A check message will be displayed, so press the   key, select "Yes" and then press the  key.



- 4 This completes the character properties changes.



## Registering Blanks (blank data) at User-set Distances

The space between characters can be inserted by considering the distribution positions, but inserting distances accurately is difficult. At such time, register a blank data to insert a space.

- 1 Press the   key.

### Reference

Blanks are inserted immediately after the layout where the cursor is currently positioned.

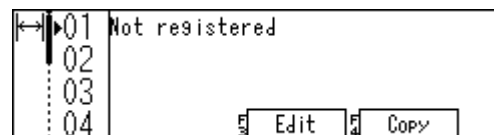

- 2 The blank selection screen will be displayed.  
Select the number of the blank to be edited, and then press the  (Edit) key.

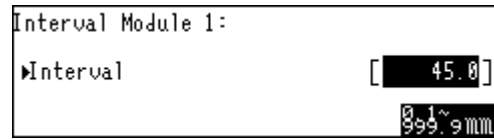

- 3** The blank (interval module) edit screen will be displayed. Edit the distances (intervals), and then press the  key.

- In this example, 45.0 has been entered.



- 4** A check message will be displayed, so press the   key, select "Yes" and then press the  key.



- 5** The blank have been registered, so register this data to the message.

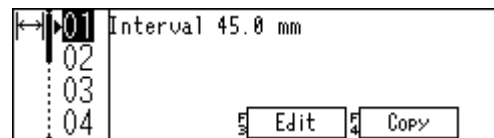

Select the blank registered in the message, and press the  key.



- 6** The blank has been registered to the message.



## Entering Characters Not on the Control Panel

- 1** Firstly, change the layout after the blank space for 2-line printing. Use the cursor to select the layout information, and then press the   key.

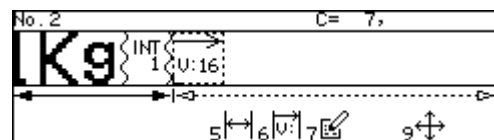

- 2** Refer to the layout settings to change the conditions as described below.

- Vertical: 20 dots
- Lines: 2

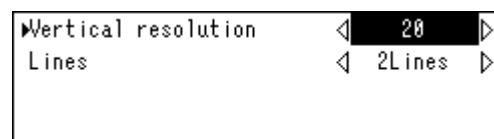

- 3** Move the cursor to the (90,0) position, and enter the LOT No." Press the  A key.

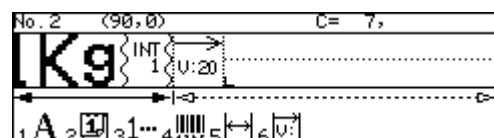

**4** Enter the "LOT Nr" by pressing the character keys on the control panel.

The character key corresponding to the "." is not on the control panel, so press the **F1** (Select) key to select the character.



**5** The characters that can be selected are displayed in the center left of the screen, so press the **F2** key or **F3** key repeatedly until "Sign" is displayed.



**6** Select the "...", and press **Ent** key. When the details have been entered as desired, press the **F4** (End) key.



**7** This completes the "LOT 番号"(mean 'LOT No') entry.

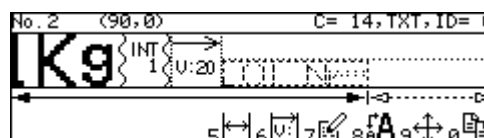

**8** Refer to changing character properties to edit the conditions as described below.

- Font size: 9 x 7
- Char.Direction: (Unchanged)
- Multiple: 1 (Unchanged)
- Char.Space: 1

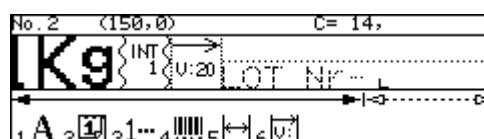

## ■ Character Entry Screen

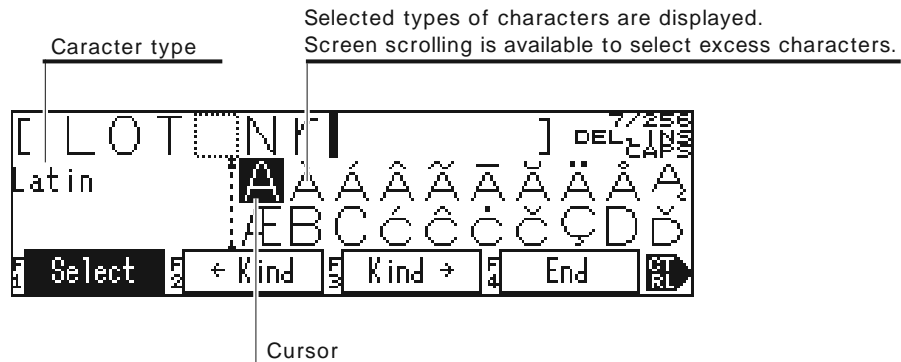

Key	Explanation
	Moves the cursor.
to [A] to [F]	Functions in the character code input mode. Enters a character code.
	Returns to the previous screen.
	Enters the character selected using the cursor.
(Select)	Ends selecting characters, and enables to enter characters using the control panel.
(<Kind)	Displayed only when editing Text module or Calendar module.
(Kind>)	Changes the types of characters that can be selected.
(End)	Terminates the inputs.

During editing Text module or Calendar module if you press the **F2** **F3** key, the selectable character type will be changed as follows.

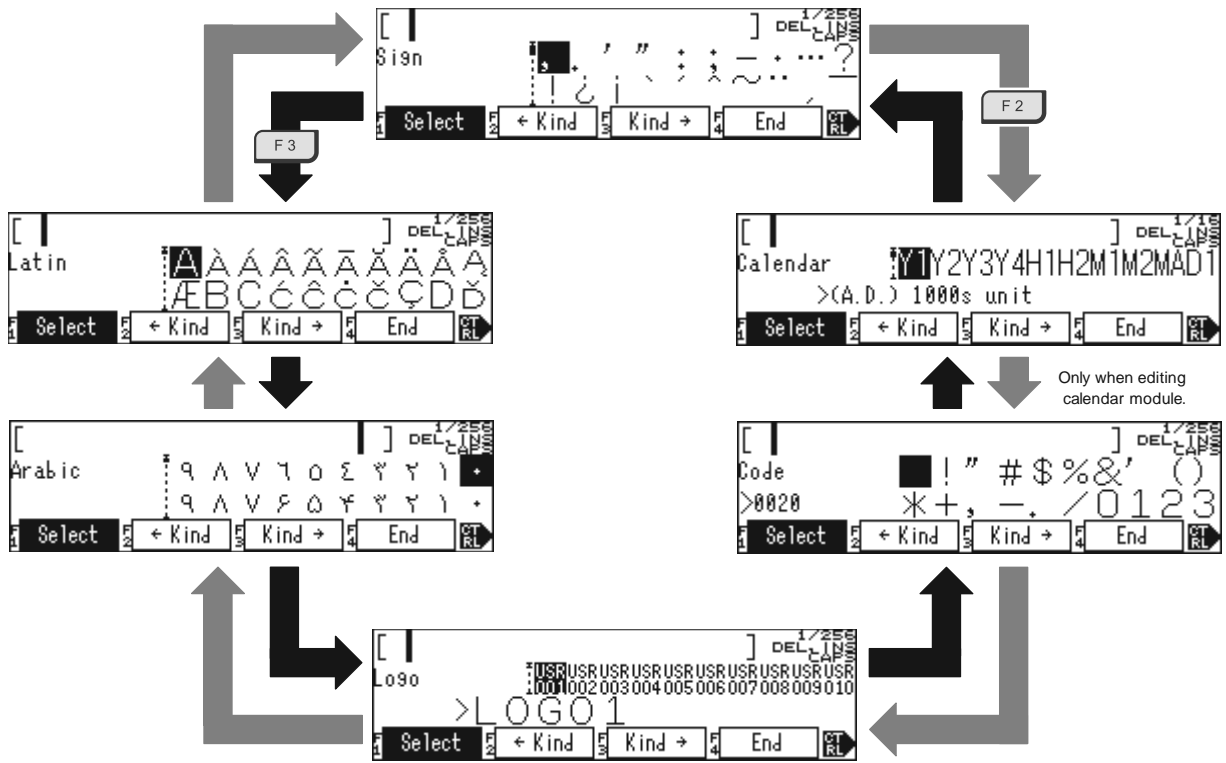

In editing Barcode module, special signs for barcode will be displayed as follows. (Selectable characters change depending on Barcode type)

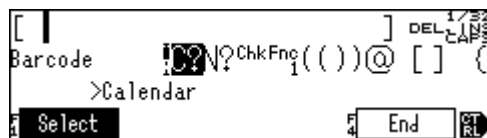

## Registering Numbering Characters

### 1 Register new numbering characters.

Firstly, move the cursor to the registration start position.

- In this example, move the cursor to the (150,0) position.

Next, press the  1... key.

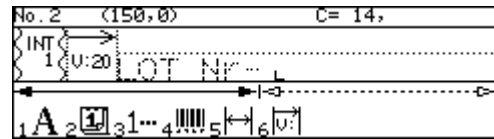

### 2 The numbering character selection screen will be displayed.

Select the number of the numbering character to be edited, and press the  (Edit) key.

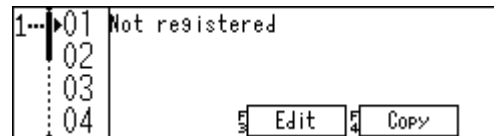

### 3 The numbering character edit screen will be displayed, so edit as described below, and then press the key.

- Figure: 8 (unchanged)
- Start: 1234567
- Increment: +2
- Stop: 99999999
- Repeat: 3
- Date update reset: OFF (unchanged)
- Zero suppress: OFF (unchanged)

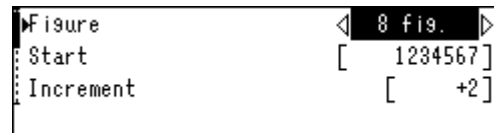

Note: The above settings are printed in the following order.

"1234567" "1234567" "1234567"

"1234569" "1234569" "1234569"

"1234571" "1234571" ...

### 4 A check message will be displayed, so press the key, select "Yes," and then press the key.



### 5 The numbering character have been registered, so register this data to the message.

Select the numbering character registered in the message, and press the  key.

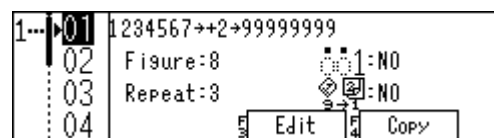

**6** The numbering character has been registered to the message.

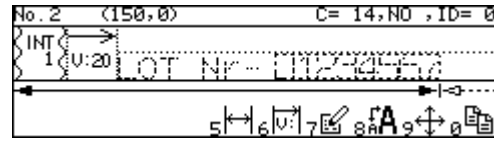

**7** Refer to "Changing Character Properties" to edit the conditions as described below.

- Font size: 9 x 7
- Char.Direction: (Unchanged)
- Multiple: 1 (Unchanged)
- Char.Space: 1

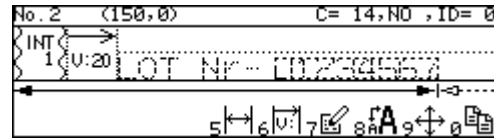

## Registering Date Characters

**1** Register new calendar characters.  
Firstly, move the cursor to the registration start position.

- In this example, move the cursor to the (90,10) position.

Next, press the **[2]** **[1]** key.

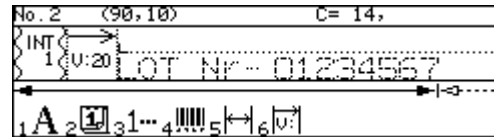

**2** The calendar character selection screen will be displayed.

Select the number of the calendar character to be edited, and press the **[F3]** (Edit) key.

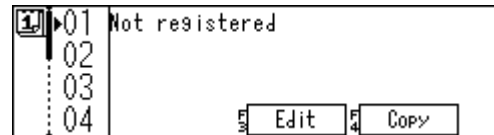

**3** Enter the "Used by" by pressing the character keys on the control panel.

And press the **[F1]** (Select) key to enter the expiration date.

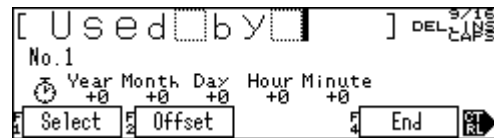

**4** Select "Character type: Calendar".

The calendar symbols (Y1, Y2... etc.) will be displayed as character candidates that can be selected, so enter using the following protocol.

- "Y3" 10s unit for western calendar
- "Y4" 1s unit for western calendar
- ". " Enter [. ] directly from the control panel.
- "M1" 10s unit for months
- "M2" 1s unit for months
- ". " Enter [. ] directly from the control panel.
- "D1" 10s unit for days
- "D2" 1s unit for days

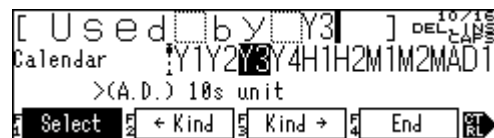

- 5** Entry of the character details has been completed, but if left as is, the current time will be printed, so enter the difference between the current time and the expiration date.

Press the **F2** (Offset) key.

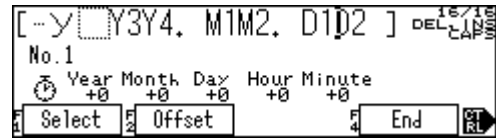

- 6** The offset amount edit screen will be displayed. Enter the difference between the current time and the time to be printed, and press the **Ent** key.

- In this example, use +1 year.



- 7** Entering the calendar characters has been completed, so press the **F4** (End) key to save the settings.

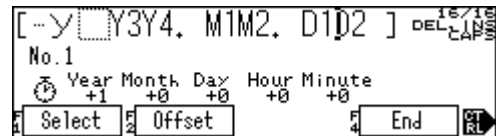

- 8** A check message will be displayed, so press the **◀▶** key, select "Yes," and then press the **Ent** key.



- 9** The calendar character have been registered, so register this data to the message.

Select the calendar character registered in the message, and press the **Ent** key.

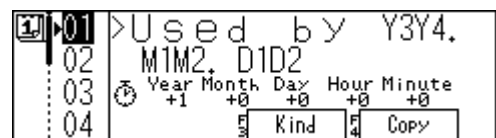

- 10** The calendar character has been registered to the message.

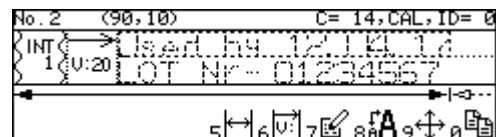

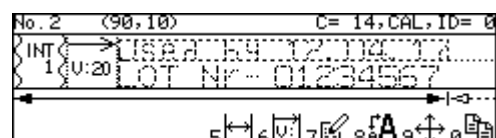

- 11** Refer to changing character properties to edit the conditions as described below.

- Font size: 9 × 7
- Char.Direction: (Unchanged)
- Multiple: 1 (Unchanged)
- Char.Space: 1





## Registering Barcode

- 1** Register new barcodes.

First of all, change back layout of Calendar characters to the one for one line. Press the   key.
- 2** Referring to “Setting the Layout Conditions”, edit conditions as follows.

  - Vertical: 26 dots
  - Lines: 1
- 3** Move the cursor to where registering begins.

Now, move the cursor to the (221, 0) position. Next, press the   key.
- 4** Image for selection for barcode will be shown.

Select the number for the barcode for editing. Press the  (Edit) key.
- 5** Image for editing for barcode (ITF) will be shown.

Input takes place by pressing “0123” and [Character] keys on the operation panel.
- 6** When input is made, press the  (Detail) key.
- 7** Detailed setting image for barcode will be shown.

(Detailed settings image is divided into several groups. Here the setting item for barcode height will be shown.)

Edit conditions as follows.

  - Height: 17

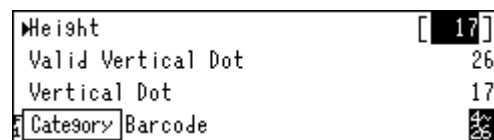
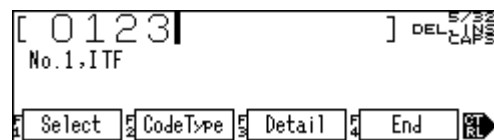
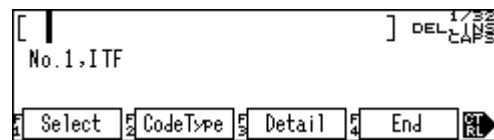
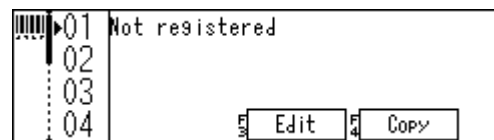
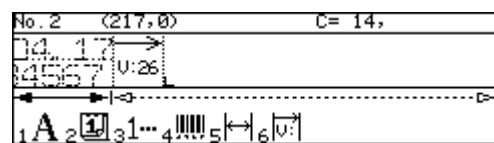
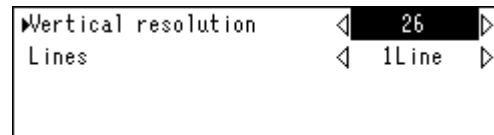
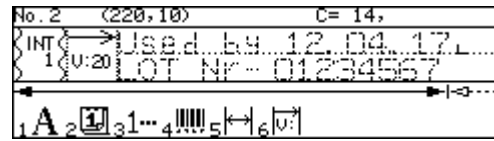

- 8** When the editing is over, press the  (Category) key.

As the setting items for OCR will be shown, edit conditions as follows.

- Append OCR: OK
- Space: 1
- Omit CD: OK
- Divide: Cancel

Append OCR	< OK >
Space	[ 1 ]
Omit CD	< OK >
Category	OCR

#### Reference

To change classification for setting items, press the  (Category) key.

- 9** When editing is over, press the  (Category) key.



As the setting items for Bearer-bar will be shown, edit as follows.

- Append BR-Bar: OK
- BR-Bar Horz.: 4
- BR-Bar Vert.: 10

Append BR-Bar	< OK >
BR-Bar Horz.	[ 4 ]
BR-Bar Vert.	[ 10 ]
Category	BR-Bar

- 10** As the barcode characters have been input, press the  key to store them.

[ 0123 ]	DEL	ESC
No.1,ITF		
OCR, BR-Bar		
Select	CodeType	Detail
End		ENT

- 11** A check message will be displayed, so press the   key, select "Yes", and then press the  key.

Save data?
< YES >

- 12** As the barcode has been registered, register this data in the message.

Select the barcode contents to be registered in the Message and press the  key.

01	>0123	
02	ITF,Vert=26dot	
03	OCR, BR-Bar	
04		Edit Copy



- 13** Now the barcode has been registered in the Message.

No. 2	(217,0)	C= 14, BAR, ID= 0
04	17	
05	U:26	
		
5	6	7
8	9	0

## Saving Message Numbers

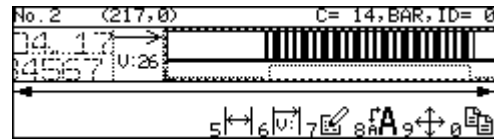
**1** Once the print data have been edited as desired, press the  key in the message edit screen.



**2** A check message will be displayed, so press the   key, select "Yes," and then press the  key.



This completes the creation of the print data.

Afterwards, try actual printing, and reedit or edit the print conditions as required.

# 5 Advanced Use

## Character / Printing Calibration

### Characters Used

The following characters can be used.

Use country	Characters
JAPAN CHINA	Alphabet, numeral, symbols, hiragana, katakana, kanji (JIS No.1 and No.2 standards), simplified Chinese characters (GB2312), and user-defined characters (192 characters max.)
Other	Latin and Arabic alphabet, numeral, symbols, and user-defined characters (192 characters max.)

### Character Height

The character height is set in 29 steps.

The height of the actual characters for the print target is related both to this set value, and the distance from the print head to the print target.

When the distance to the print target is fixed, printing using character height 29 is magnified approximately 3.6 times the height of character size 1. Character height can be set for each message.

### Horizontal Dot Pitch

This function sets the pitch between dots along the width of the characters. The pitch can be set for each message in the range 0.10mm to 10.00mm.

### Density

This function sets the character darkness. Density is added by overprinting immediately after printing one vertical line. Density can be set for each message in the range 1 to 4.

For example, with density 2, immediately after one vertical line has been set, the same content is printed once again immediately.

### Interspacing

This function inserts unused ink droplets when printing between the ink droplets used in printing to improve the print quality. The greater the interspacing, the better the print quality, but the slower the print speed. Interspacing can be set for each message.

Can be edited in the range 0 to 15, only when "Manual" has been selected for "Interspacing type settings". In reality, however, the settable range depends on the number of scan dots, the print speed, and the horizontal dot pitch.

When "Auto" has been selected, set the optimum "interspacing" from other settings. And display "interspacing" with a decimal convenience because a change of "interspacing" makes it plain.

### Print Position

This function sets the distance to the point where print actually starts after print command signal is inputted.

The position can be set for each message in the range 0 to 999.9mm.

## Print Speed

By setting the conveyer speed beforehand, the details of the items set by the distance such as print position and horizontal dot pitch, etc., are correctly expressed in the print results.

Print speed can be set for each message in the range 1.0 to 350.0m per minute. In reality, however, the settable range depends on the number of scan dots, the horizontal dot pitch, and the interspacing.

If the conveyer speed fluctuates greatly, printing can be performed using the rotary encoder speed tracking signals.

## Print Style

This function sets the top/bottom of characters, writing direction and vertical/horizontal/mirror writing.

Configuration of printing style includes the followings:

Print direction, and top and bottom: Set for each message

Writing direction and top/bottom of characters: set for each module

Examples of top/bottom of characters and writing direction:

		Print orientation	
		Normal	Down
Character direction	↑	(Print direction : Forward) → <b>I NKJET</b> ← (Print direction : Back)	(Print direction : Forward) → <b>TEJKN I</b> ← (Print direction : Back)
	↓	(Print direction : Forward) → <b>I NKJET</b> ← (Print direction : Back)	(Print direction : Forward) → <b>TEJKN I</b> ← (Print direction : Back)

Examples of using character direction:

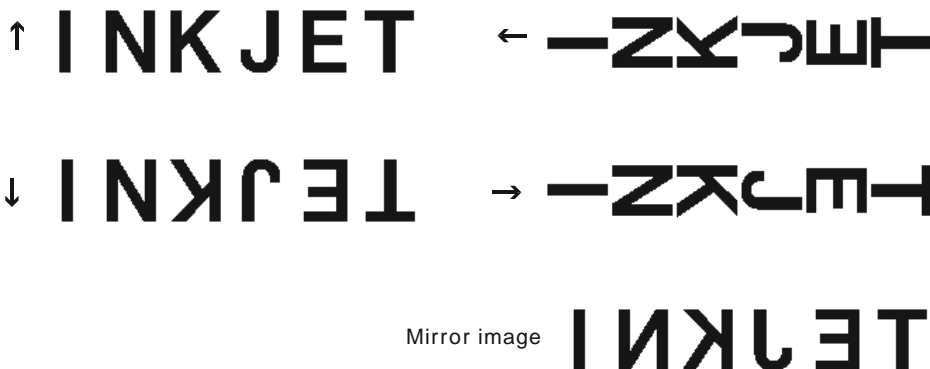

## Filter

Print commands use photoelectric sensors or external signals. If chattering occurs in these signals, trouble such as failure to print, print position error, or skipping numbering, etc., may occur. This occurs due to the chattering timing and a characteristic that ignores print commands entered during CCS-R print operations (print position standby and printing after the print command has been entered). Examples of the nonconformance are described below.

### ■ If the spacing between jobs is too narrow: No printing

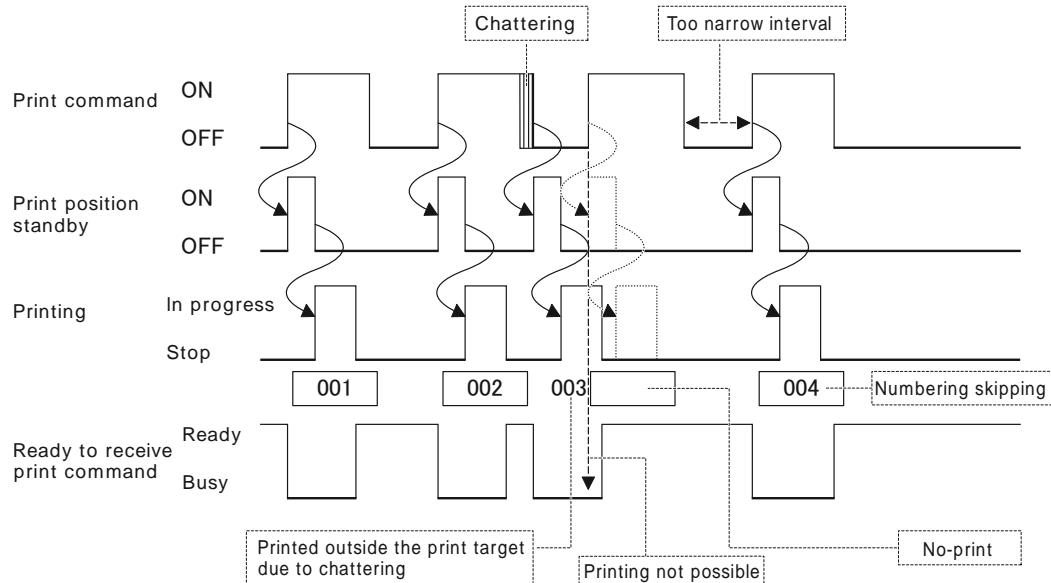

### ■ If the spacing between jobs is even narrower: Print position error

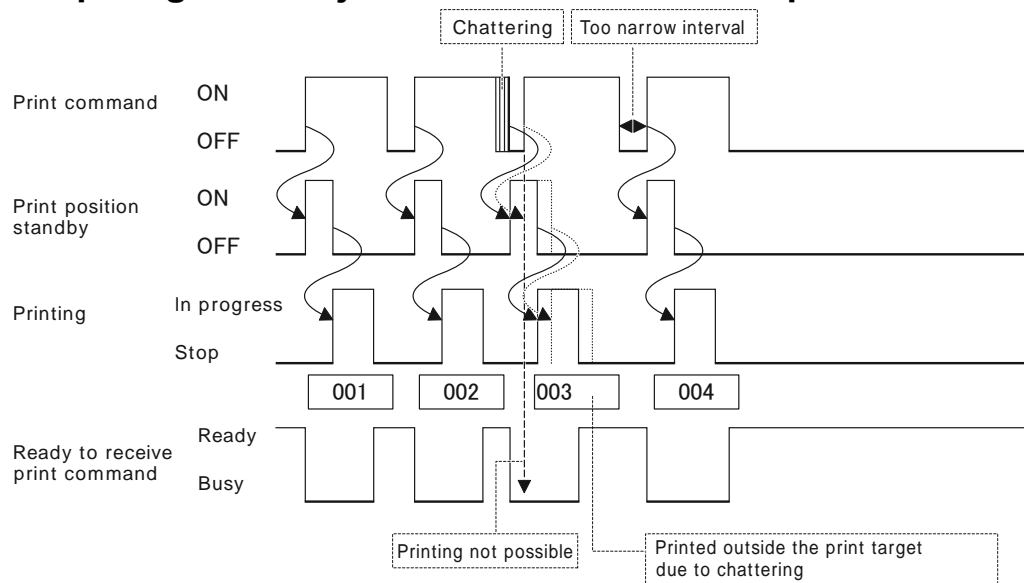

■ If the space between jobs is too great: skipping numbering

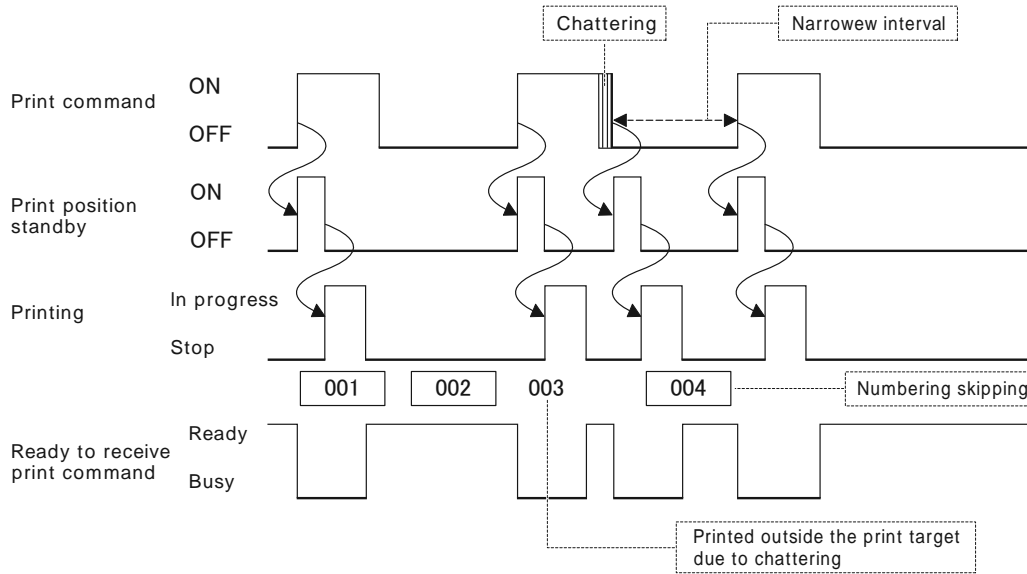

CCS-R is equipped with a "filter" function to prevent this type of trouble. The "filter" functions to remove exceptional print commands by performing compensation within the CCS-R even if chattering occurs in the photoelectric sensors (or external signals). There are two types of compensation, "OFF Filter" and "ON Filter", both of which are set using the distance (in mm), and conform even if a rotary encoder is connected. If not in use, set the value to 0. Further, both the ON and OFF filters can also be used simultaneously.

■ OFF filter operation

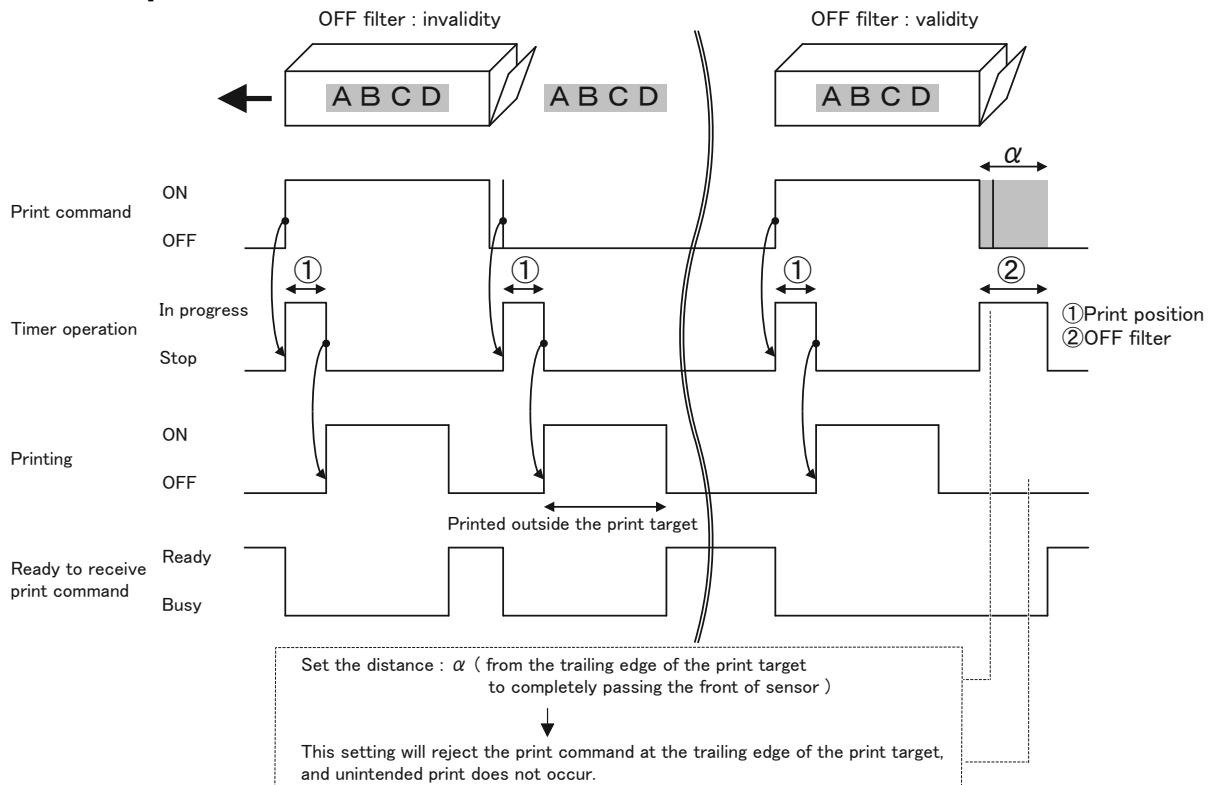

**Internal compensation method:** Aims to prevent troubles such as the misprints described above by ignoring print commands entered over the set distances even if the print command has been completed.

## ■ ON filter operation

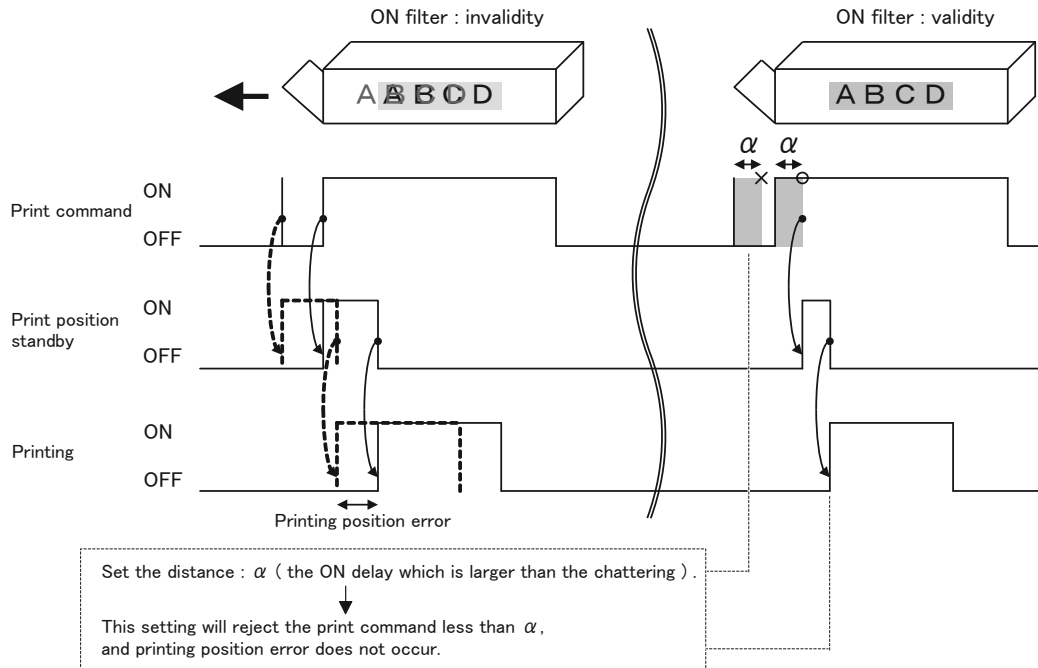

### Internal compensation method:

Aims to prevent the troubles described above by rechecking after the print command has been turned ON and the set distance has been traveled. If the signal is ON, printing is performed, and if the signal is OFF, the print command is ignored.

### ! Caution

- This function is for handling chattering only. Care is required as it is presumed that chattering does not occur as far as possible.
- This function cannot be used with the tracking function.
- With repeat printing, this function is enabled for either the first or last printing only.
- If using the ON delay, the character position setting must be set smaller than the delay setting.
- Set the optimum distance.

If the setting is too great, the next case might not be printed due to the distance between jobs.  
If the setting is too small, the effect will not be realized.

---

## Repeat Printing

This function repeatedly prints the same content to the number of times specified.

The following two types of print conditions can be selected.

**Trigger:** Prints repeatedly the specified number of times after the print command has been turned ON.

The number of times can be set from 1 to 9999.

**While ON:** Prints repeatedly the specified number of times while the print command is turned ON. If the print command is turned OFF before the specified number of times has been reached, however, printing will stop at that point in time. Further, if the print command is turned OFF during printing, the message being printed will finish being printed before the command is turned OFF.

The number of times can be set from 0 to 9999, and infinity (set to 0).

The pitch of the repeats can be set. Here, the pitch specifies the distance from the end of the previous printing to the start of the next printing. The distance can be set from 0.0 to 999.9mm.

Repeat printing can be set separately for each message.

**Calendar update:** Determines whether to refresh the calendar module during repeat printing.

**Numbering update:** Determines whether to update the numbering module during repeat printing.

**Forced end by P.disable:**

Determines whether to end repeat printing using either a print prohibition input signal or the print prohibition key.

## Multiple Size Printing

This function prints by expanding the characters along the horizontal.

The magnification function magnifies in the horizontal direction only; the vertical size does not change. Magnification can be set from x1 to x8 (1 is normal print size) for each module.

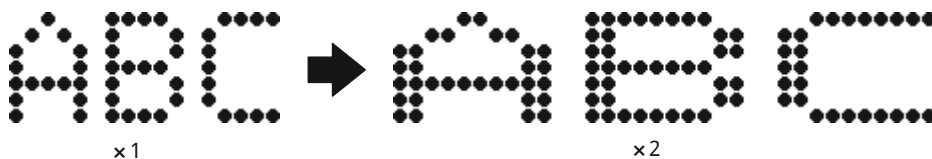

## Character Spacing Setting

This function adjusts the distance between characters.

The set unit is dots, and can be set for each module separately in the range of 0 to 31 dots.

This function can also be set to apply a space of the set distance after the final character of the module.

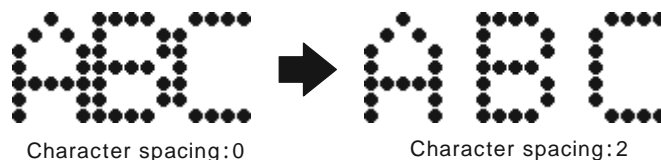

# Calendar Module

This function performs printing while automatically updating the production date and expiration date (i.e., best before), etc.

10 calendar modules can be registered.

The expiration (best before) date is defined using offsets against the production date (for example, one month from the production date), and the expiration date offset can be set in units of years, months, days, hours, and minutes.

## Calendar Characters

Dates and times in the calendar module are expressed using calendar characters.

Calendar characters are printed by being replaced with the characters allocated using the "character allocation setting".

Character	Meaning	Actually Printed	Character	Meaning	Actually Printed
Y1	1000s unit for years (Western calendar)	2 0 0 0 0 1 0 1	m2	1s unit for minutes	1 5 2 3 4 5
Y2	100s unit for years (Western calendar)	2 0 0 0 0 1 0 1	S1	10s unit for seconds	1 5 2 3 4 5
Y3	10s unit for years (Western calendar)	2 0 0 0 0 1 0 1	S2	1s unit for seconds	1 5 2 3 4 5
Y4	1s unit for years (Western calendar)	2 0 0 0 0 1 0 1	DN	Date number	Described separately
H1	10s unit for years (Japanese calendar)	H 1 2 . 1 . 1	MP	AM and PM characters	Described separately
H2	1s unit for years (Japanese calendar)	H 1 2 . 1 . 1	DW	Day of the week	Described separately
M1	10s unit for months	2 0 0 0 0 1 0 1	WN	Week number	Described separately
M2	1s unit for months	2 0 0 0 0 1 0 1	DT	Start, middle, or end of the month	Described separately
MA	Month 1-digit expression	Described separately	DC	Day 1-digit expression	Described separately
D1	10s unit for days	2 0 0 0 0 1 0 1	YX	Western calendar 2-digit expression	Described separately
D2	1s unit for days	2 0 0 0 0 1 0 1	MX	Month 2-digit expression	2 0 0 0 0 1 0 1
T1	10s unit for hours (24-hour clock)	1 5 : 2 3 : 4 5	DX	Day 2-digit expression	2 0 0 0 0 1 0 1
T2	1s unit for hours (24-hour clock)	1 5 : 2 3 : 4 5	TX	Hour 2-digit expression	1 5 2 3 4 5
TA	Hour 1-digit expression	Described separately	mX	Minutes 2-digit expression	1 5 2 3 4 5
t1	10s unit for hours (12-hour clock)	PM 0 3 2 3 4 5	SX	Seconds 2-digit expression	1 5 2 3 4 5
t2	1s unit for hours (12-hour clock)	PM 0 3 2 3 4 5	mA	Minutes 1-digit expression	Described separately
m1	10s unit for minutes	1 5 2 3 4 5	SC	Shift code	Described separately

' ' describes the replacement position of the character symbol.

---

## ■ MA: Month 1-Digit Expression

Prints the months January to December by replacing with 1-digit characters.

The default settings are described below.

Month	1	2	3	4	5	6	7	8	9	10	11	12
Replacement	1	2	3	4	5	6	7	8	9	A	B	C

## ■ TA: Hour 1-digit Expression

Prints the hours from 0 to 23 in the 24-hour clock by replacing with 1-digit characters.

The default settings are described below.

Hour	0	1	2	3	4	5	6	7	8	9	10	11
Replacement	A	B	C	D	E	F	G	H	I	J	K	L
Hour	12	13	14	15	16	17	18	19	20	21	22	23
Replacement	M	N	O	P	Q	R	S	T	U	V	W	X

## ■ DN: Date Number

The date number is also called the Julian date, and is the number of the date throughout the year, starting with 1 as 1 January.

The Julian date is expressed using three digits, and the topmost digit is filled in using 0. (Zero suppression is disabled.)

The Julian date is calculated based on the amount of calendar offset, and when the year changes the date is reset to "001"

January 1st "001"

January 2nd "002"

December 30st "364" (In leap years, 365)

December 31st "365" (In leap years, 366)

January 1st of the follow year "001"

The default replacement settings are common to each of three digits the following settings are made for all (three) digits. (A separate replacement pattern cannot be specified for an individual digit.)

Value	0	1	2	3	4	5	6	7	8	9
Replacement	0	1	2	3	4	5	6	7	8	9

### ■ MP: AM and PM Characters

AM and PM characters express morning and afternoon, and print the one character replaced after being calculated based on the amount of calendar offset.

The default for the changeover time between AM and PM is 12:00, but this can be changed using the calendar settings. (The changeover from PM to AM is fixed at 0:00.)

The default settings are described below. If printing the characters "AM" and "PM", use in combination with "M".

AM/PM	AM	PM
Replacement	A	P

### ■ DW: Day of the Week

Prints the day of the week calculated based on the amount of calendar offset using the single character that has been replaced.

The default settings are described below.

Day of the Week	Sun	Mon	Tue	Wed	Thu	Fri	Sat
Replacement	1	2	3	4	5	6	7

## ■ WN: Week Number

The week number is the number replaced in weekly units, taking 1 January to be Week 1.

The week number is expressed using two digits, and the topmost digit is filled in using 0. (Zero suppression is disabled.)

The week number is calculated based on the amount of calendar offset, and when the year changes the week is reset (i.e., 1 January becomes Week 1 again).

Further, the day of the week on which the week starts can be changed using the calendar settings. (The default is Sunday.)

Example (Start day is Sunday)

January							
Sun	Mon	Tue	Wed	Thu	Fri	Sat	
		1	2	3	4	5	January 1 to 5 Week 1
6	7	8	9	10	11	12	January 6 to 12 Week 2
13	14	15	16	17	18	19	January 13 to 19 Week 3
20	21	22	23	24	25	26	January 20 to 26 Week 4
27	28	29	30	31			January 27 to 31 Week 5 -

Example (Start day is Wednesday)

January							
Wed	Thu	Fri	Sat	Sun	Mon	Tue	
						1	1 January Week 1
2	3	4	5	6	7	8	January 2 to 8 Week 2
9	10	11	12	13	14	15	January 9 to 15 Week 3
16	17	18	19	20	21	22	January 16 to 22 Week 4
23	24	25	26	27	28	29	January 23 to 29 Week 5
30	31						January 30 to 31 Week 6 -

In the default, the following settings are made for all (two) digits. (A separate replacement pattern cannot be specified for an individual digit.)

Value	0	1	2	3	4	5	6	7	8	9
Replacement	0	1	2	3	4	5	6	7	8	9

### ■ DT: Beginning, Middle, and End of the Month

Prints a single character dividing one month into the beginning, middle, and end.

The default settings are described below.

Period	Replacement
1 to 10 of the month	Beginning
11 to 20 of the month	Middle
21st of the month to the end	End

### ■ DC: Day 1-digit Expression

Prints the dates within a month by replacing with single-digit characters and AM or PM.

The default for the changeover time between AM and PM is 12:00, but this can be changed using the calendar settings. (The changeover from PM to AM is fixed at 0:00.)

The default settings are described below.

Date	1	2	3	4	5	6	7	8	9	10	11	12	13	14	15
Replacement	1	2	3	4	5	6	7	8	9	A	B	C	D	E	F

Date	16	17	18	19	20	21	22	23	24	25	26	27	28	29	30	31
Replacement	G	H	I	J	K	L	M	N	O	P	Q	R	S	T	U	V

Both AM and PM are set using the same details.

### ■ YX: Expresses the Year Using 2 Digits

Prints ten-year periods from the base year by replacing with 2-digit characters.

If a period greater than 10 years from the base year has elapsed, the data is printed by returning to year 1 again, and if the number of years that have elapsed from the base year is negative, the data is printed using the absolute value of the elapsed years.

The default settings are described below.

Base Year	2000									
No. of Years Elapsed Since the Base Year	0	1	2	3	4	5	6	7	8	9
Replacement	00	01	02	03	04	05	06	07	08	09

Printing using the default settings is as described below.

Year	1998	1999	2000	2001	2002	2003	2009	2010	2011
Actually Printed	02	01	00	01	02	03	09	00	01

## ■ mA: Minute 1-Digit Expression

Prints the minutes within an hour by replacing with 1-digit characters. The default settings are described below.

Minute	0	1	2	3	4	5	6	7	8	9	10	11	12	13	14
Replacement	0	1	2	3	4	5	6	7	8	9	A	B	C	D	E

Minute	15	16	17	18	19	20	21	22	23	24	25	26	27	28	29
Replacement	F	G	H	I	J	K	L	M	N	O	P	Q	R	S	T

Minute	30	31	32	33	34	35	36	37	38	39	40	41	42	43	44
Replacement	U	V	W	X	Y	Z	a	b	c	d	e	f	g	h	i

Minute	45	46	47	48	49	50	51	52	53	54	55	56	57	58	59
Replacement	j	k	l	m	n	o	p	q	r	s	t	u	v	w	x

## ■ SC: Shift code

One day is divided into max 10 work shift, and can print some characters (1 to 10) for each work shift.

The example of printing are described below.

Range (example)	Print data (example)
0:00 to 5:29	S1
5:30 to 11:59	S2
12:00 to 18:29	S3
18:30 to 23:59	S4

## Calendar Character Replacement

Normally, the production date and the expiry date are printed using Arabic numerals but, for example, printing 99.10 as 99.X is possible by replacing the 10th month (October) with "X".

Replacement for each calendar character unit are possible, such as for the 1000s and the 100s, etc., and all characters that can be printed using this machine can be replaced.

Replaced characters are commonly referenced by all production date modules and expiry date modules.

There is only one type of replacement. Consequently, it is not possible to replace October with "X" in one message, and replace October with "Y" in another message.

Zero suppression is possible depending on the calendar character replacement. However, there is no function to left-align the figures by filling in the blank.

## Day of the Week Setting

This function sets which day of the week to use as the start of the week.

The function is referenced when printing the number of weeks elapsed since the start of the year using the week number character, which is one of the calendar characters.

## PM Switchover Timing Setting

This function enables the PM switchover to be set to an hour and minute of your choosing.

The function is referenced when printing using a single calendar character for AM and PM.

The normal setting is 12:00, and only one type can be set.

## Setting the Method to Calculate Expiry Date Displays

If the date calculated based on the amount of calendar offset does not actually exist, it must be adjusted to an actual date. (For example, if the "offset amount: 1 month" is set to 31 January, then exactly one month later would become the non-existent date of 31 February.)

The machine enables three types of calculation methods (adjustment methods) to be selected.

Calculation Method	Adjustment Method
Start of Month	If the calculated result does not actually exist, adjusts to the first day of the following month.
Carried-over	If the calculated result does not actually exist, the number of days until a date that does exist from the day of calculation is added to the following month.
End of the Month	If the calculated result does not actually exist, adjusts to the last day of that month.

This function is enabled if the offset amount "year" or the "month" is other than zero. If offset amount is specified using the number of days only, the date is calculated just by adding the offset amount to the production date.

For example, if the expiry date offset are one month or 30 days, the expiry dates are calculated as follows:

Production Date	Expiry Date (If is not a leap year)			Expiry Date Setting 30 Days
	Expiry Date Setting One Month			
	Start of Month	Carried-over	End of the Month	
1. 28	2. 28	2. 28	2. 28	2. 27
1. 29	3. 1	3. 1	2. 28	2. 28
1. 30	3. 1	3. 2	2. 28	3. 1
1. 31	3. 1	3. 3	2. 28	3. 2
2. 1	3. 1	3. 1	3. 1	3. 3

---

## Start of week number setting

This function sets the first week of week number.

The function is referenced when printing using a single calendar character for week number.

Settings	Operation
January 1	The first week of a year starts with January 1st.
Week of 1st Sun ~ Week of 1st Sat	The first week of a year is a seven-day period that contains the first given day of the year.

## Numbering Module

This function performs printing while automatically updating the number according to the number of printings made.

The numbering digits can be set between 1 and 8. In addition to the numbering, the following settings are also possible. A maximum of 10 items can be registered.

Initial value, end value, and count up/count down

Increment (how many counting up or counting down.)

Advance (counting up or counting down at that time of how many times the same value is printed.)

Return to initial value when the date is updated, and zero suppression (Convert zero to space.)

### Numbering Character Replacement

Numbering is normally printed using Arabic numerals but, for example, this function can print 11 as AA by replacing the number 1 with the letter "A".

All characters that can be printed by this machine can be allocated by the user to the numbers from 0 to 9.

### Changing the Current Numbering Value

This function changes the current value of the numbering and the incremental advance.

The function is used to set a specific value as the current numbering value if trouble occurs, or to continue printing a numbering run from the previous day, etc.





The current numbering value can be changed separately for each numbering module.

## Barcode Module

Print the bar pattern to correspond to the registered data (numericals and signs) .

- You can register upto ten barcode modules.
- You can freely set the size of the bar element.
- As it is assumed that the barcode printed will be read by a reading device, printing quality is extremely important.
- Readability rate largely depends on printing environment and performance of the reading device. Such being the case it is strongly recommended for the user to conduct the reading test in the user's environment.

### Printable Barcode

Type	Image and Characteristics	Number of digits	Size	Standard for reference
ITF	 <p>Which stands printing codes smaller than others as far as the number of digits is the same.</p>	2 to 32 (even digits)	2	ISO / IEC 16390
Code39	 <p>Alphabets and signs acceptable.</p>	1 to 32	5 (large)	ISO / IEC 16388
NW-7	 <p>Signs printable.</p>	No regulations	3	ANSI / AIM BC3-1995, USS-Codabar
EAN	 <p>Standardized as a prevailing code.</p>	13 or 8 digits (including one CD digit)	1 (small)	ISO / IEC 15420
Code128	 <p>Can handle 1byte and 2byte ASCII signs.</p>	No regulations	4	ISO / IEC 15417

CD : Check digit

Type	Character type	Bar type	Print quality requirement	Risk rate for incorrect readability
ITF	Numericals	2 steps x 2 colors	Normal	High
Code39	Alphanumericals and signs. ( -.\$/+% )	2 steps x 2 colors	Normal	High
NW-7	Numericals and signs. ( -.\$/+ )	2 steps x 2 colors	Normal	Normal
JAN	Numericals	4 steps x 2 colors	High	Normal
Code128	one byte ASCII character (Code area : 00h to 7Fh)	4 steps x 2 colors	High	Low

## ■ Requirements for barcode printing

The followings are the pre-requisites for printing barcodes correctly.

Conditions	Contents
Conveyor	Low speed. The speed at which the substrate passes the printhead should be constant.
	The distance between the printhead and the substrate should be 20 mm or less at all times.
	Conveyor vibration should be minimum. Not applicable to the roller conveyor.
	Vibration should not be conducted to the printhead.
Substrate	The substrate material should be such that the ink may not blur.
	The surface of the substrate should be smooth.
	The substrate material shall have the reflectance that ensures the MRD value specified in each bar code standard (The RL value shall be 50% or more).
Installation environment and others	Be sure that the air blown by the air conditions should not be applied between the printhead and the substrate.
	Space must be secured for maintaining the printhead.
	Environment should be such that the printing plane should be kept from touching by any foreign material after printing and before ink drying.

## ■ Bar density

The bar density of the barcode can be set by the horizontal dot pitch setting for printing conditions. ( Refer to " P32: Setting the print conditions". )

Horizontal dot pitch	Bar density	Ink blurring after printing
A gap formed between bars may cause failure.	When being less dense, MRD value may not be secured and cause poor readability	Bar width consistent, thus good for good readability
10.0	Low (less dense)	Small (bar width consistent)
0.2	High (more dense)	Large (bar width can be widened)
	Causes good readability	As the bar width is inconsistent, it could cause bad readability

As the blurring property depends on the substrate material, be sure to make readability adjustment to the appropriate value by testing.

## Setting Items of Each Code

It is required to make settings as below in addition to data for encoding of barcode.  
 ( Refer to" P107: Barcode Module Details". )

Type	Image	Items to be set
ITF		<ul style="list-style-type: none"> <li>• Bar height</li> <li>• OCR</li> <li>• Distance between characters</li> <li>• OCR division</li> <li>• Bearer bar, Horizontal line width, and Vertical line width</li> </ul>
Code39		<ul style="list-style-type: none"> <li>• Bar height</li> <li>• OCR</li> <li>• Distance between characters</li> <li>• Start-character and stop-character omitted for OCR</li> </ul>
NW-7		<ul style="list-style-type: none"> <li>• Bar height</li> <li>• Change Start-character and Stop-character (SC)</li> <li>• OCR</li> <li>• Distance between characters</li> <li>• SC omitted for OCR / SC made smaller</li> </ul>
EAN		<ul style="list-style-type: none"> <li>• Bar height</li> <li>• OCR</li> <li>• Distance between characters</li> </ul>
Code128		<ul style="list-style-type: none"> <li>• Bar height</li> <li>• OCR</li> <li>• Distance between characters</li> </ul>

## Characters Registerable

Characters registerable for each barcode type are as below.

You can create a barcode pattern by registering these number of characters and module in the barcode module.

Type	Number of data	variable character	Check digit (CD)
ITF	2 to 32 (even number)	Supporting	Modulus 10 / 3
Code39	1 to 32	Supporting	Modulus 43
NW-7	1 to 32	Supporting	Modulus 16
EAN	7 or 12	Supporting	Modulus 10 / 3
Code128	1 to 32	Supporting	Modulus 103

The CD of EAN and Code128 is for internal calculation and will be automatically added.

Sp, for JAN. set the digit to the given number minus one.

### ■ Normal character

Type	Characters registerable															
ITF	0	1	2	3	4	5	6	7	8	9						
Code39	0	1	2	3	4	5	6	7	8	9	-	.	\$	/	+	%
	A	B	C	D	E	F	G	H	I	J	K	L	M	N	O	P
	Q	R	S	T	U	V	W	X	Y	Z	(SP)					
NW-7	0	1	2	3	4	5	6	7	8	9	-	.	\$	/	+	:
EAN	0	1	2	3	4	5	6	7	8	9						
Code128	!	"	#	\$	%	&	'	(	)	*	+	,	-	.	/	0
	1	2	3	4	5	6	7	8	9	:	;	<	=	>	?	@
	A	B	C	D	E	F	G	H	I	J	K	L	M	N	O	P
	Q	R	S	T	U	V	W	X	Y	Z	[	\	]	^	_	`
	a	b	c	d	e	f	g	h	i	j	k	l	m	n	o	p
	q	r	s	t	u	v	w	x	y	z	{		}	~	(SP)	

FNC1

## ■ Variable character

Variable characters such as module type or number can also be registered as barcode.

Variable character	Image display
Calendar module	CAL    CAL 01 ~ 10
Numbering module	NUM    NUM 01 ~ 10

- Others than numbers should be ignored.
- In the event the digit setting barcode may not correspond to the right digit, then add zero in an automatic mode to make adjustment.

## ■ Check digit (CD)

It is possible to add a function in the barcode such that Check digit (CD) may be automatically calculated for addition.

Variable character	Image display
Check digit (CD)	chk Dis

- First CD to calculate from the leading end of the data.
- When more than one CD are registered, calculation will be made for the contents of the CD of the immediate preceding CD and later CDs.

### Caution

- To deal with variable characters allocated ignore such allocation and conversions should take place as a value.
- When the zero-suppress setting has been made in numbering, ignore zero-suppress and encode the leading zero as well.
- Where there are Calendar characters that may not be encoded, ignore them and put forward the latter characters.

MA / DC	Month / Day : one digit
TA / mA	Hour (24h) / Minute : one digit
YX / MX / DX	Year / Month / Day : two digit
TX / mX / SX	Hour / Minute / Second : two digit
MP / DW / DT	am and pm character / Day of the week / Early-Middle-Late Month

## About Code 128

Refer to below for Code 128 in the CCS-series.

### ■ Optimization

In Code 128, some codes of group A duplicate to those in the group B while the codes that will not duplicate are special codes for use for ESC sequence. This is why CCS will not employ the codes of group A.

In other words, CCS uses codes in Group B and code of Group C for connecting numbers in order to keep the code length minimum. This is called optimization.

Where the number continues for more than six digits, they will be switched to the codes in the group C.

As the codes in the group C for two digits of numbers can be described by one character.

So, where the number continues, the code length can be kept minimum.

### ■ Supporting EAN128

In EAN 128, A.I. (application identifier) will be put in the brackets. Such brackets will be shown in OCR but will not be included in the codes. So, in CCS those inside the brackets are treated the same way.

When the codes inside the brackets be included in the codes, then they can be treated as one character by consecutive ((.

As FUNC1 is used as the Delimiter (Terminator) of the variable length data it can be input with CCS.

### Caution

- Variable character will be prioritized. Where there are Check digit, Calendar or Numbering in the character line, they are treated as a priority as a Variable character.
- OCR will not print Check digit.

## Barcode Module Details setting

In the screen of "Barcode Module Details" setting will take place for others than those to be encoded. Some of the important points will be explained below.

### ■ To set barcode height

Height does not include OCR. In setting to 18 dots or more, OCR has nothing to add.



Bearer bar of ITF, top and bottom bar will be printed in the vertical dots.

### ■ About omitting CD:

When Check digits is registered in the Barcode module, it is possible to print by omitting CD only with OCR characters.

## ■ About division of OCR

The standard regulations of ITF defines that spacing is made in OCR as below. With CCS spacing can automatically be inserted by setting so.

Number of digit	Version	Division position	
6	Add on	12345 6	 12345 6
14	Standard	123 45678 90123 4	 123 45678 90123 4
16	Extension	12345 67890 12345 6	 12345 67890 12345 6

## ■ About start and stop character

With Code 39 / NW7, the start character and the stop character can be added at the leading and the trailing ends.

Type	Start character	Stop character
Code39	*	*
NW7	Select from A, B, C, and D.	Select from A, B, C, and D.

With CCS it is possible not to print this character to OCR by setting so.

(The specifications of standard regulations allows this function to be added to the barcode data.)

In the case of NW7, you can select small character as start and stop character.

## ■ About settings of Bearer bar

To set items related to Bearer bar. (Only for ITF)

### Caution

- To add Bearer bar it is required to set a length ten times long of the fine white bar as the blank dots space. (Addition will be made outside the blank.)
- The width above and below Bearer bar must have height shorter than the two times value of it.

## ■ About character settings

Starting and ending charactes can be changed. (Only for NW7)

### Barcode Setting

In the screen for barcode setting, setting of barcode module space and bar element size will be made. There are eight bars at maximum by the combination of black, white, thin and thick bars.

To set number of dots to be used for printing each.

Be sure to confirm the imaging size for all messages for which the barcode module has been registered.

#### ! Caution

- There could be an error of excessive size with the message for which others than the objective barcodes are registered depending on the setting contents.

Type	Image
ITF	<p>(2) (3) (6) (7)</p> <p>Left quiet zone Right quiet zone</p> <p>(1) Narrower Line            (2) Narrow Line            (3) Wide Line            (4) Wider Line            (5) Narrower Blank            (6) Narrow Blank            (7) Wide Blank</p>
Code39	<p>Gap between bar-character (2) (3) (6) (7)</p> <p>Left quiet zone Right quiet zone</p> <p>(8) Wider Blank</p>
NW-7	<p>Gap between character (2) (3) (6) (7)</p> <p>Left quiet zone Right quiet zone</p>
EAN	<p>(1) (2) (3) (4) (5) (6) (7)</p> <p>Left quiet zone Right quiet zone</p>
Code128	<p>(8) (1) (2) (3) (5) (6) (7)</p> <p>Left quiet zone Right quiet zone</p>

# Interval Module

This function inserts long spaces between characters.

The space can be set in millimeters from 0.1 to 999.9mm. A maximum of 10 intervals can be registered. A blank character can be used for short spaces, but this function is effective if the space is long and the number of characters is insufficient.

# User Fonts

## Creation Flow

Normally, user fonts are created using the following flow.

## Selecting User Font Storage Numbers

**1** Press the **F2** (Edit) key in the [Main Menu].

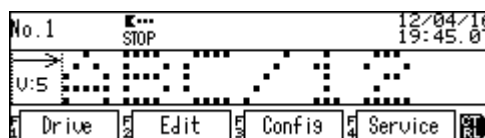

**2** The edit functions will be displayed, so press the **▲▼** keys to select "Edit Logo", and then press the **Ent** key.

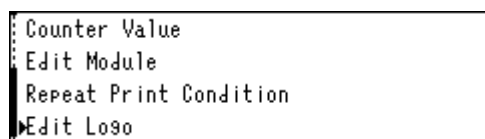

### Reference

Logo (User fonts) cannot be edited while the head is in operation.

**3** The user font information screen will be displayed, so press the **F1** (Font) key.

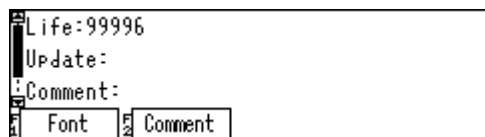

**4** The user font selection screen will be displayed, so select the number to be stored (from 001 to 192) using the **▲▼** keys.

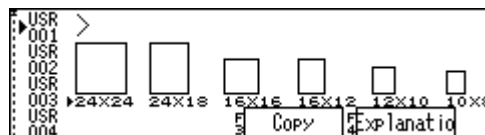

In this example, select **USR001 (001)**.

**5** Next, select the font size using the **▲▼** key, **Ent** key.

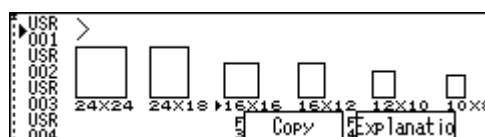



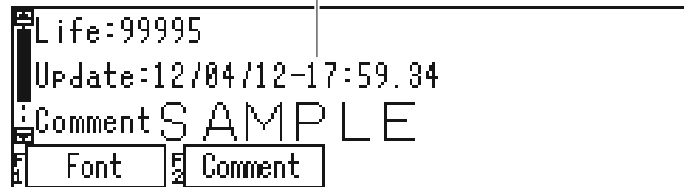

In this example, select **16 x 16**.

## ■ User Font Information Screen

Displays the information about the user font



User Font Information	Explanation
Life	Displays the number of possible user font updates.
Update Date	Displays the date and time the details were last updated. * Not displayed immediately after shipment.
Comment	Edits comments.
No. of Registrations	Displays the number of registered user fonts.
Version	Displays the version of the user font at the time of shipment.

Key	Explanation
	Enables the user to scroll the user font information.
 (Font)	Edits the user fonts.
 (Comment)	Edits comments.
	Ends user font operations. * If editing a user font, saves the edit to memory.

## ■ User Font Selection Screen

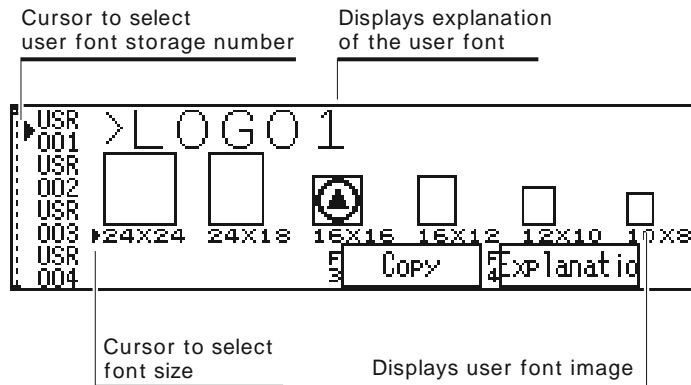

Key	Explanation
	Enables cursor selection and scrolling of the number under which the user font has been saved.
	Enables cursor selection and scrolling of the size of the user font to be edited.
(Copy)	Copies the explanatory text and user font.
(Explanation)	Edits the text that explains the user font (1 character).
	Deletes the explanatory text and user font.
	Edits the user font size and storage number that have been selected.
	Returns to the previous screen.

## Editing User Fonts

- 1 The user font edit screen will be displayed, so the font pattern can be edited.



- 2 When editing has been completed, press the key to finish the editing.

When the key has been pressed, the edit still has not been saved, so printing cannot be performed.



## ■ User Font Edit Screen

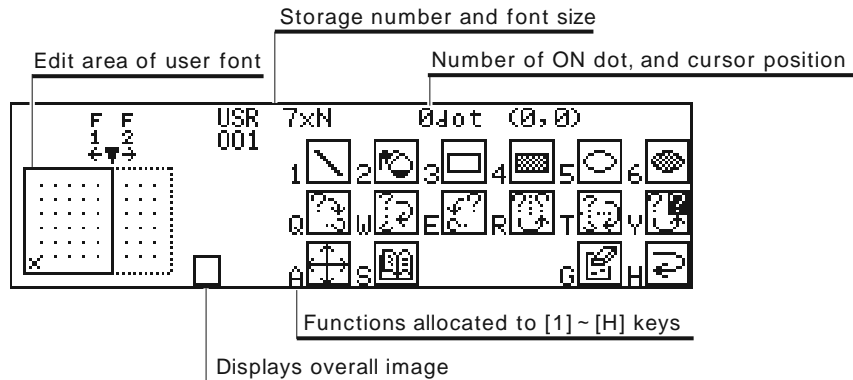

Key	Explanation
	Moves the cursor.
	When edit the proportional font, change the font width.
to [H]	Implements the allocated functions. For the allocated functions, refer to "Function Icons" below.
	Turns ON and OFF the dots.
	Ends editing.
	Returns to the previous screen.

Function Icons	Explanation
	<b>Straight line</b> Draws a straight line to connect the start and end points.
	<b>Fill</b> Fills in and deletes the filling within the bounded area.
	<b>Move</b> Moves the complete pattern.
	<b>Rectangle (outline only)</b> Draws a rectangle with opposite corners at the start and end points.
	<b>Rectangle (filled)</b> In the "filled" case, the interior of the rectangle is filled.
	<b>Ellipse (outline only)</b> Draws an ellipse with opposite sides at the start and end points.
	<b>Ellipse (filled)</b> In the "filled" case, the interior of the ellipse is filled.
	<b>90 deg rotation</b> Rotates the complete pattern at an angle of 90 degree.
	<b>180 deg rotation</b> Rotates the complete pattern at an angle of 180 degree.
	<b>-90 deg rotation</b> Rotates the complete pattern at an angle of -90 degree.
	<b>Horizontal reverse</b> Reverses the complete pattern along the horizontal orientation.
	<b>Vertical reverse</b> Reverses the complete pattern along the vertical orientation.
	<b>Black/white reverse</b> Reverses the dot format of the complete pattern.
	<b>Read</b> Reads the font saved to CCS-R as a pattern.
	<b>Delete</b> Deletes the whole pattern.
	<b>Undo</b> Returns to the pattern immediately before the last operation.

## ■ Dot ON (Draw) and OFF (Delete)

**1** Press the keys to move the cursor.

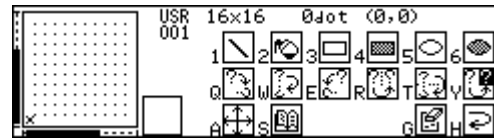

**2** Press the key to turn ON and OFF the dots.

Press and hold the key while pressing the keys to draw a straight line.



## ■ This section explains the functions allocated to the keys to [H] first using " : Ellipse (filled)" as an example.

**1** First move the cursor to the start point, and then press the key.



**2** Next, press the (dots ON) key.

To turn OFF the dots press the key, and to stop processing, press the key.

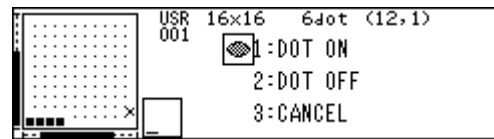

**3** First move the cursor to the start point, and then press the (Confirm) key.

To stop processing, press the key.

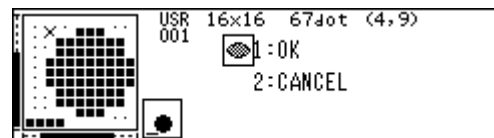

**4** Drawing has been completed.





\* : Straight line", " : Rectangle (outline only)" " : Rectangle (filled)", and " : Ellipse (outline only)" can also be drawn using the same procedure.

### ■ "Fill" Command

**1** First move the cursor to the area to be filled, and then press the   key.



**2** Press the  (Dots OFF) key.

To turn ON the dots press the  key, and to stop processing, press the  key.

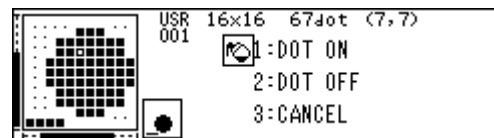

**3** Filling has been completed.



### ■ "Move" Command

**1** Press the [A]  key.



**2** Press the     keys to move the whole pattern, and then press the  (OK) key.

To stop processing, press the  key.

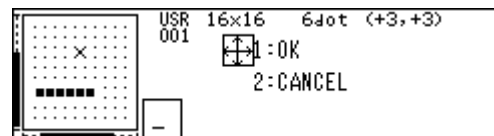

**3** Movement has been completed.



### ■ "Delete" Command

**1** Press the [G]  key.



**2** The whole pattern has been deleted (dots are turned OFF).



## ■ "☐: Undo" Command

**1** Press the [H]  key.

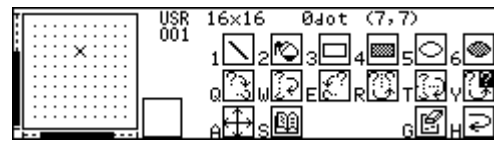

**2** Returns to the pattern immediately before the last operation.



## ■ "☐: 90deg Rotation" Command

**1** When the allocated functions have been changed, press the [Q]  key.



**2** The whole pattern has been rotated 90 degrees.





\*† "☐: 180deg Rotation", "☐: -90deg Rotation", "☐: Left/Right Reverse", "☐: Top/Bottom Reverse", and "☐: Black/White Reverse" can also be performed using the same procedure.

## ■ "☐: "Read" Command

**1** Move the cursor to the position at which to read the font pattern, and press the [7]  key.



**2** Press the   keys to select the font size. Enter the character to be read, and then press the  key.

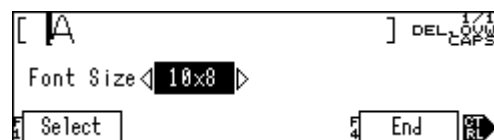

**3** The font pattern has been read.



## Entering Explanatory Text

- 1 Editing the font pattern has been completed, but the explanatory text is "unregistered", so printing cannot yet be performed.

Press the **F4** (Explanation) key to enter the explanatory text.

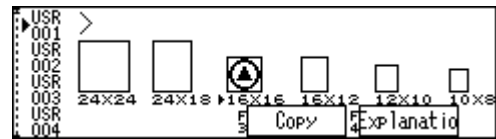

- 2 Enter the explanatory text, and then press the **Ent** key.

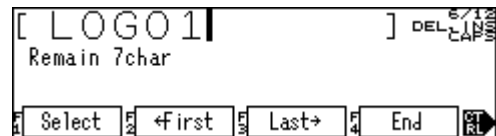

- 3 The explanatory text has been entered. If there are no other user fonts to be edited, press the **Esc** key to return to the previous screen.

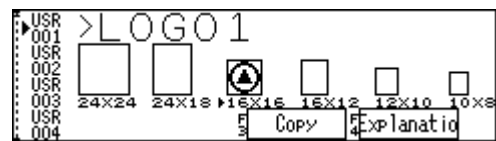

## Saving the Edited Contents

- 1 After returning to the user font information screen, press the **F2** (Comment) key and enter a comment about the user font if required.

Comments do not need to be edited.



- 2 Press the **Esc** key to close the user font information screen.



- 3 If the contents have changed, a check message to update the memory contents will be displayed.

To perform the update, select "Yes", and then press the **Ent** key.

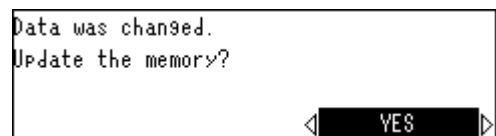

This completes the user font creation.

If a user font has been created using this example, the following will be displayed in the screen for registering user fonts to messages.

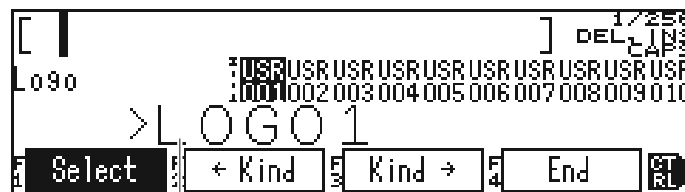

Displays explanation of the user font

In this example, only the font size 16 × 16 has been registered, so to print using other font sizes, a 1-character space (blank) will be printed.

# Managing Consumables

A consumables management function is built into CCS-R. If set in advance, at the set time an information screen will be displayed (and a buzzer will sound), to notify that the set date has arrived. Use this function to estimate when to replace parts that must be replaced periodically.

## Operations Explanation

This section explains the setting procedure and operations using ink management as an example.

- 1 Set the replacement period according to the type of ink to the date obtained by adding the replacement date to the current date.

Example: Replacement period is five months from today, 1 January 2007

- Set the replacement method to "Date".
- Set Day "1" Month "6" Year "2007".

Further, at this time, the replacement period can be set automatically by entering the ink type set at the time of factory shipment by pressing the **F1** (Auto) key.

- 2 After the set period has elapsed, the elapsed time notice screen will be displayed when the power supply is turned ON. (A buzzer will also sound at the same time.)

Subsequent operations can be selected using this screen.

- Release** : Clears the settings.
- Reset**: Displays the advanced settings screen. Make the settings again.
- Continue**: Move to the regular screen keeping the current settings.

Normally, press select "Continue" to solve problems using the regular screen. (using the ink example, replace the ink and make the settings again.)

Further, the icons are displayed in the main header at this time, to show that "continue" has been selected.

If "continue" has been selected, the elapsed time notice screen is also displayed the next time the power supply is turned ON. (The display will continue until released, or the settings are made again.)

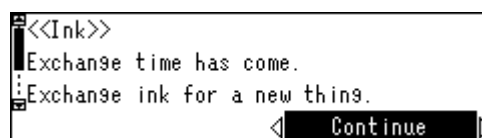
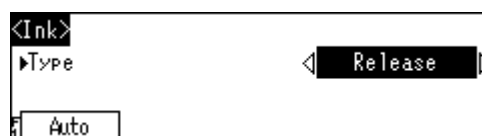

The icon which shows a fixed period.

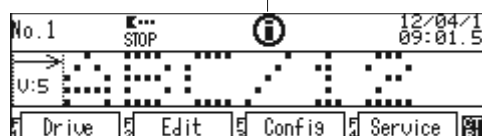

## Settings Procedure

**1** Select "Manage Consumables" in the service screen. The advanced settings screen will be displayed.

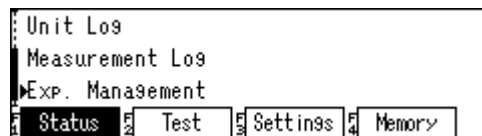

**2** Move to the advanced settings screen by selecting the items.

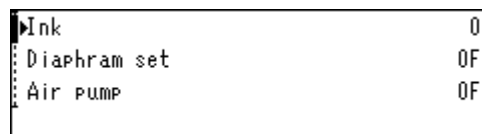

**3** Make the advance settings.



### Selectable type and settings range

Type	Meaning	Remarks
Release	No settings have been made.	
Date	Sets the date in the future. Occurs the alarm on startup after the specified date.	
Cumulative	Sets cumulative time at 0 to 12000 hours. Occurs the alarm on startup, after the specified hours from the settings operation.	
Counts	Sets the number of times the gutter has been closed at 1 to 10000. Occurs the alarm on startup, after the specified number of times or more gutter has been closed.	
Monthly	Sets the date of the month at 1 to 31. Occurs the alarm during startup of the specified day of every month.	Free only
Weekly	Sets the day of the week at Sunday to Saturday. Occurs the alarm during startup of the specified week of every week.	Free only
Daily	Occurs the alarm at every startup.	Free only

### Other

- All management data is deleted when the internal data is initialized.
- This data is not copied if copying data from another CCS-R.
- The type, 'Date', 'Monthly', and 'Weekly' are compared with the system-clock.
- The type of 'Cumulative' is compared with the 'Turn ON time'.
- The type of 'Counts' is compared with the 'GOC (Gutter open / close) times'.
- The type of 'Free1' and 'Free2' are the management item that can be set freely. Must enter the contents of the 20 characters (1 to 20 char.) consumables.

---

# Other Functions

## Speed Tracking Printing

Printing can be performed at a fixed pitch even if the conveyor speed fluctuates violently by receiving speed tracking signals from a rotary encoder.

Either the internal clock or a rotary encoder can be set as the print clock.

The following settings are available if using a rotary encoder.

- No. of pulses per rotation
- Distance per rotation
- Rotation direction

These set values must satisfy the following conditions.

$$\frac{(\text{No. of pulses per rotation}) \times 4}{(\text{Distance (mm) per rotation}) \times 10} \geq 2$$

## Interval Operation

This function turns ON the power supply automatically at the specified date (day of the week and time), circulates ink with the gutter closed, and turns OFF the power supply at the specified time. The ink temperature can be stabilized and stable printing performed during actual use by turning ON the power supply before the start of printing when using this function. Further, if the machine is not used for a long period of time, ink solidification can be prevented in the nozzle by using this function.

## Tracking Function

This function prints in order by maintaining detection of multiple jobs. If the distance between the head and the photoelectric sensor is great due to the installation, turn "ON" this function. (1310mm max.)

- A maximum of six jobs can be detected. (Any more are ignored.)
- If the print position is "0" or one-shot printing is "ON" the tracking function will not operate even if it is turned "ON".
- If the next print job is started while printing is still being performed, the current job will be prioritized, and the start of the next job will be ignored.

## Forced Printing

This function prints using control panel key operations only.

Photoelectric sensor inputs are unnecessary, so mainly use this function to determine the cause if trouble occurs.

## Operations Log Display

Displays a record of the power supply being turned ON and OFF, operating and stopping, and malfunctions occurring.

## I/O Test

This function can test operations such as monitoring external input signals, output signals, and the pumps and valves, etc.

## System Status Display

Displays the system software, DSP software, and font versions that have been installed, and the status of the settings switches.

# External I/O

## I/O Signals

Signal Name	Signal Meaning
/Printing Possible	Shows that the head is able to receive print command signals.
/Replacement Required	Shows that the remaining ink and/or solvent is insufficient.
/Alarm	Explains that operations have been disabled due to some type of malfunction.

For details, refer to the IO Connection Specifications.

# Communications

This function enables data inputs and settings to be performed using communications from the host to the machine using the RS-232C port that is built in as standard. The main specifications are described below.

Max. Cable Length	15m
Max. Baud Rate	76800bps
Connector Type	D-SUB 9P; male
Signals	TXD, RXD, DTR, DSR, RTS, and CTS

For details of the commands, refer to the User Manual (Communications).



# 6 Explanation of Display

## Screen Configuration Table

Level 0		Level 1		Level 2		Level 3		Level 4	
93	Main menu	94	Unit information	96	Unit information (Detail)				
		97	Edit	98	Select Message				
				99	Print Condition				
				101	Counter Value				
				102	Repeat Print Condition				
				103	Edit Module	105	Calendar module editing	105	Calendar offset editing
						106	Numbering module editing		
						107	Barcode module editing	107	Barcode module details
						109	Interval module editing		
				110	Edit Message	111	Message editing	112	Message layout
								113	Text module editing
								113	Character properties
								103	Special module registration
				79	User Font Information	80	User font selection	81	User font editing
	114	Config	System	115	System Clock				
				116	Interval Running				
				118	Unit Config				
				119	CHG Detect Rectify				
				121	Interspacing Type				
				121	Head heater Config				
			Ext. I/O	122	Encoder Config				
				123	Ph. Sensor Monitoring				
				124	Transmit Config				
				125	I/O Output Condition				
				126	Priority Management				
			Etc.	127	Calendar Config				
				128	Shift-code Config				
				129	Operation Config				
				130	Level Config				
				131	Change Password				
				132	No. Date Renewal				
				132	Replace char. selection	133	Replace char. editing (1)	133	Replace char. editing (2)
				134	Barcode Config				

¶ Describes page number.  
to be continued next page

Level 0	Level 1	Level 2	Level 3	Level 4
93	Main menu			
	135	Service		
		Status	136	System Status
			136	Work Log
			137	Unit Log
			138	Measurement Log
			139	Exp. Management (1)
			139	Exp. Management (2)
		Test	96	Unit Test
			140	Forced Print
			141	Bleed Process
			141	Forced mixing
			142	Recirculation Process
			143	Draining Process
			144	I/O Test
		Settings	145	Head parameter

•¶ Describes page number.

## Screens Explanation

The screens are described below.

### Main Menu

With the CCS-R main menu screen, this screen is displayed after the power supply has been turned ON, so operations can be performed.

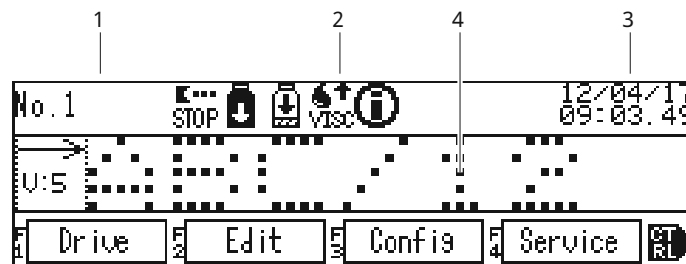

Item	Explanation
1	Displays the number of the message to be printed.
2	Displays unit status icons.
3	Displays the system clock.
4	Displays the print image.

Key	Process
	Scrolls the print image.
(Drive / Stop)	Turns ON and OFF the head operation.
(Edit)	Performs print-related editing.
(Config)	Performs unit-related settings.
(Service)	Performs maintenance-related operations.
	Switches the functions allocated to the keys  to .
(Allocated function 1)	Displays the function that was set with 'Operation Config' screen.
(Allocated function 2)	Displays the function that was set with 'Operation Config' screen.
(Unit Info)	Displays the unit information screen.
(Quit)	Ends the CCS-R.

Icons that describe unit status.

Icon	Explanation
	Head is stopped.
	Head is operating (or the operation is being processed).
	Head cover is open.
	Ink amount is low.
	Solvent amount is low.
	Ink viscosity is too high.
	Ink viscosity is too low.
	The ink leak out from the ink pump. When this icon is displayed, the ink pump is stopped, and then cannot operate the head.
	Consumables have exceeded replacement time.

## Unit Information

Displays the status of the sensors and valves, etc., in the unit.

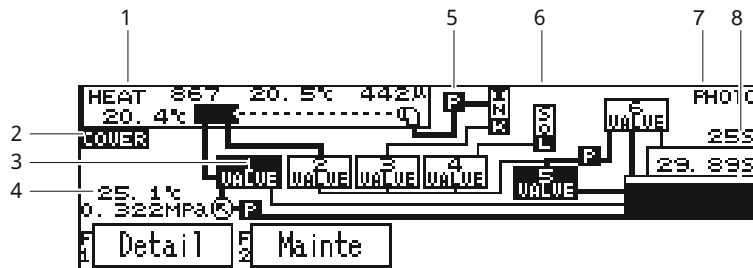

Item	Explanation
1	From top left <ul style="list-style-type: none"> <li>• Head heater ON/OFF status</li> <li>• Piezo voltage (command value)</li> <li>• Head temperature</li> <li>• Charge detection time ( while head is operating only)</li> </ul> Bottom <ul style="list-style-type: none"> <li>• Displays the head heater temperature.</li> </ul>
2	Displays whether the head cover is mounted or removed.
3	Displays the operation status of the valves.
4	(Top): Displays the unit temperature. (Bottom): Displays the ink pressure.
5	Displays the ink pump operation status. (The three pumps operate in union.)
6	Displays whether there is solvent in the solvent tank. (The ink tank display does not change, regardless of whether or not there is ink.)
7	Displays the input status of print commands from the external sensor.
8	(Top): Displays the time to supply ink to the viscosity measuring tank. (Bottom): Displays the ink fall time (i.e., ink viscosity).

Key	Process
<b>F 1</b> (Detail)	Displays the unit test screen.
<b>F 2</b> (Mainte)	Switches to maintenance mode.
<b>Esc</b>	Returns to the previous screen.

In maintenance mode, the gutter, valves, pumps, and head heater, etc., can be operated individually. The display for the part being operated is highlighted.

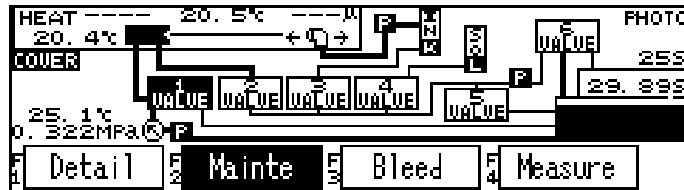

Key	Process
<b>[H]</b>	Turns ON and OFF the head heater.
<b>[P]</b>	Turns ON and OFF the ink pump.
	Opens and closes the gutter. Turns OFF automatically when the gutter is fully open or fully closed.
<b>1</b> to <b>7</b>	Turns ON and OFF the valves. Valves 3 and 4 will not turn ON when the mixing tank is full. (7th valve is displayed only in the case of pigment ink unit.)
<b>F 3</b> (Bleed)	Conducts the bleed processing. (The display during processing is highlighted.)
<b>F 4</b> (Measure)	Measures the viscosity. (The display during measuring is highlighted.)

\* In maintenance mode, all valves and pumps are turned OFF.

## Unit Information [Detail] (Unit Test)

Enables sensor inputs to be displayed and valves to be operated individually, etc.

### Input Display

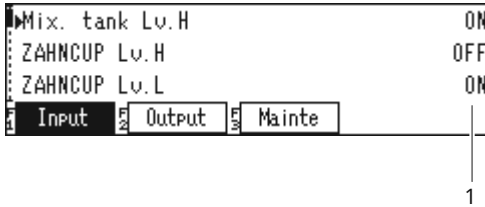

### Output Display

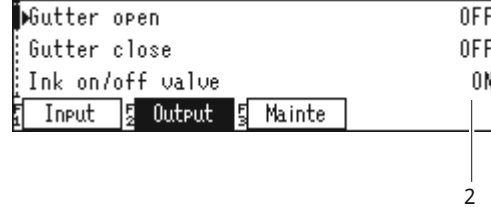

### Output Display--Maintenance Mode

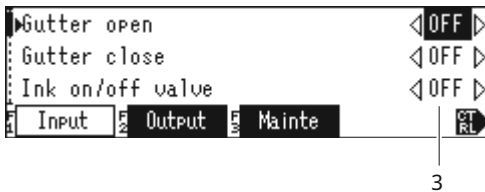

Item	Explanation
1	Displays inputs from the sensors.
2	Displays the operating status of the gutter and valves, etc.
3	Switches to gutter and valve operating status. (Stopped: OFF; Operating: ON)

Key	Process
(Input)	Switches to input display.
(Output)	Switches to output display.
(Mainte)	Switches to maintenance mode.
	Selects items and scrolls display.
	Switches to gutter and valve operating status (in output display and maintenance mode).
	Returns to the previous screen.
	Switches the functions allocated to the keys  to .
(Bleed)	Conducts the bleed processing. (The display during processing is highlighted.)
(Measure)	Measures the viscosity. (The display during measuring is highlighted.)

## Editing



Displays the print settings.

```

Select Message
Print Condition
Edit Message
Counter Value

```

Item	Explanation
Select Message	Selects the number of the message to be printed.
Print Condition	Edits the print conditions.
Edit Message	Edits the messages.
Counter Value	Edits the current counter value of the numbering module.
Edit Module	Edits the special modules.
Repeat Print Condition	Edits the print-repeating conditions.
User Font Editing	Edits the user fonts.

Key	Process
	Selects items and scrolls display.
	Determines the selections.
	Returns to the previous screen.

## Select Message

This screen selects the number of the message to be printed.

Detail display

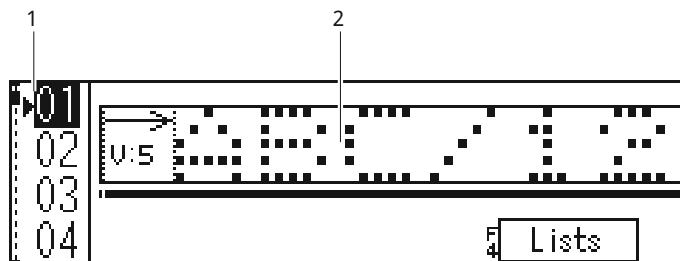

List display

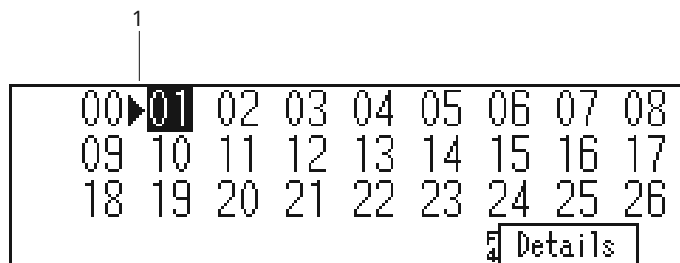

Item	Explanation
1	Displays the cursor and the number of the message selected. The print data are registered to the number displayed as highlighted.
2	Displays the print image for the selected message.

Key	Process
	Scrolls the print image (in advanced display). Selects the message number (in table display).
	Selects the message number.
 (Lists / Details)	Switches the selected message number display.
	Determines the print message number selection.
	Ends the print message number selection, and returns to the previous screen.

## Print Condition

This screen displays and edits the print conditions for the message currently being printed.



Key	Process
	Selects items to be edited, and scrolls the display.
	Increases and decreases values, and changes the selected item.
	Enters and deletes values.
	Registers edited details.
	Returns to the previous screen.
(Default)	Sets the current print conditions and repeat conditions to the default (initial) values. (The details being edited are not registered until the  key is pressed.)
(Copy)	Copies the print conditions, repeat conditions, or both conditions currently being edited to a user-defined number. (The print conditions are saved to the number for the copied message, but the edited details are not saved to the number of the message currently being edited until the  key is pressed.)
(Sel Msg.)	Edits print conditions of other message.

Edit Items	Explanation	Settings Range
Char. Height	Adjusts the size of the top/bottom orientation of the characters.	1 to 29
Horizontal Pitch	Sets the pitch between adjoining dots along the character width. Used to determine the character width.	0.10 to 10.00 [mm]
Density	Density can be increased by overprinting once again from the top characters that have already been printed.	1 to 4
Interspacing	Used to improve the print quality. The greater the number, the better the quality. * Can be edited only when "Manual" has been selected for "Interspacing type settings". When "Auto" has been selected, set the optimum "interspacing" from other settings. And display "interspacing" with a decimal convenience because a change of "interspacing" makes it plain.	0 to 15 ("Manual") 0.0 to 15.0 ("Auto")



<b>Edit Items</b>	<b>Explanation</b>	<b>Settings Range</b>
<b>Prt. Position</b>	Sets the distance from after the print command has been entered (photoelectric sensor) to the start of printing.	0.0 to 13107.1 [mm]
<b>Prt. Speed</b>	By setting the conveyer speed beforehand, the details of the items set by the distance such as print position and horizontal dot pitch, etc., are correctly reflected in the print results. * When using the rotary encoder, enter the maximum speed when the conveyer is operating.	1.0 to 500.0 [m/min.]
<b>Prt. Direction</b>	Sets whether to print the printing information from the start (forwards) or from the end (back).	Forward / Back
<b>Prt. Orientation</b>	Reflects the top and bottom orientation of the characters.	Normal / Down
<b>OFF Filter</b>	Set to prevent misoperation due to print command chattering. After printing has been completed, prevents print commands from being received between the set distance. * Set to 0.0 if not in use.	0.0 to 13107.1 [mm]
<b>ON Filter</b>	Set to prevent misoperation due to print command chattering. Waits only for the set distance after the print command has been received, and then checks the print command again. If the print command is ON, printing is performed, and if the print command is OFF, printing is not performed. * Set to 0.0 if not in use.	0.0 to 13107.1 [mm]









For details, refer to " P55: Character / Printing Calibration".

## Counter Value

This screen enables the values of the currently registered numbering module to be changed.

No.	Counter	Repeat	Print
01	1234567	1	o
02	1	1	x
Reset		Reset All	

Item	Explanation
No	The numbering module number. Only registered numbers are displayed.
Counter	Displays the current counter value. (The edited details are not saved until the  key is pressed.)
Repeat	Displays the current repeat value. (The edited details are not saved until the  key is pressed.)
Print	Displays whether the status is included in the message currently being printed.

Key	Process
	Moves the cursor for the item being edited.
	Enters and deletes values.
 (Reset)	Resets the numbering and repeat values for the selected module number. (The edited details are not saved until the  key is pressed.)
 (Reset All)	Resets the numbering and repeat values for all module numbers. (The edited details are not saved until the  key is pressed.)
	Saves the details being edited.
	Returns to the previous screen.

Note: For details, refer to the "P68: Numbering Module" for the "P49: Registering Numbering Characters".

## Repeat Print Condition

This screen displays and edits the repeat-printing conditions for the message currently being printed.



Key	Process
	Selects items to be edited, and scrolls the display.
	Increases and decreases values, and changes the selected item.
	Enters and deletes values.
	Registers edited details.
	Returns to the previous screen.
(Default)	Sets the current print conditions and repeat conditions to the default (initial) values. (The details being edited are not registered until the  key is pressed.)
(Copy)	Copies the print conditions, repeat conditions, or both conditions currently being edited to a user-defined number. (The print conditions are saved to the number for the copied message, but the edited details are not saved to the number of the message currently being edited until the  key is pressed.)
(Sel Msg.)	Edits repeat print conditions of other message.

Edit Items	Explanation	Settings Range
Repeat Print	Turns ON and OFF repeat printing.	ON / OFF
Method	Sets the relationship between repeat printing and print commands. WhileON: Performs repeat printing while the print command is ON. Trigger: Performs repeat printing using one print command (trigger).	Trigger / While ON
Times	Sets the number of prints using repeat printing. If set to "1", printing is performed twice. If set to "0" while the print mode is turned ON, printing is unlimited.	0 ~ 9999 [Times]
Interval	Sets the pitch between print data during repeat printing.	0.0 ~ 999.9 [mm]
Calendar Update	Sets whether or not to update the calendar schedule during repeat printing.	ON / OFF
Counter Update	Sets whether or not to update the numbering module during repeat printing.	ON / OFF
Forced end by P.disable	Sets whether or not to end repeat printing if a print prohibition signal is entered using Communication during repeat printing.	ON / OFF

For details, refer to " P55: Character / Printing Calibration".

## Edit Module

Use this screen to select and edit the special module types and numbers.

### Calendar Module Display

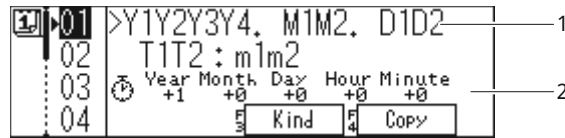

### Numbering Module Display

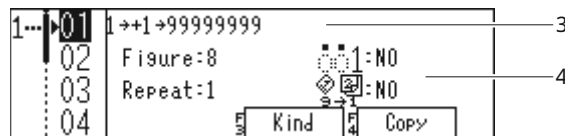



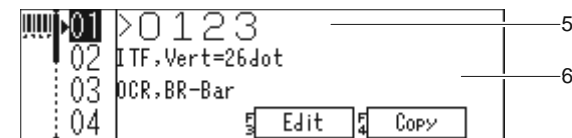

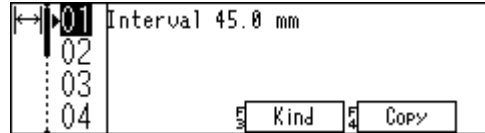

### Barcode Module Display



### Interval Module Display



Item	Explanation
1	Displays the registered details of the calendar module. (Displayed in two lines if the registered information is too long.)
2	Displays the calendar offset amount (i.e., the difference from the system time).
3	From the left <ul style="list-style-type: none"> <li>• Default numbering value</li> <li>• Amount of increment</li> <li>• Displays the numbering end value.</li> </ul>
4	From the top <ul style="list-style-type: none"> <li>• Displays the reset when updating the date.</li> <li>• Displays the zero suppression setting.</li> </ul>
5	Displays the registered details of the barcode module.
6	From the top <ul style="list-style-type: none"> <li>• Displays the barcode type and number of vertical dots.</li> <li>• Displays other options such as OCR or no OCR, etc.</li> </ul>

Key	Process
	Selects the module number, and scrolls the display.
 (Edit)	Edits the special modules (when saving to messages).
 (Kind)	Changes the kind of the special module displayed (when edit module).
 (Copy)	Copies the details of the selected module number to another number.
	Deletes the details of the selected module.
	Edits the special module, or saves to the message.
	Returns to the previous screen.

## Calendar Module Editing

This screen edits the calendar modules.

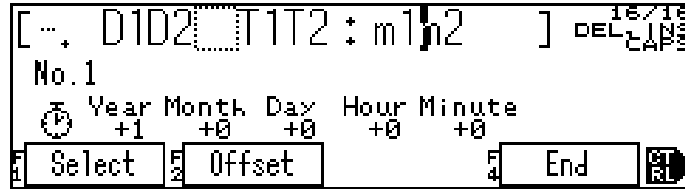

Key	Process
(Offset)	Edits the calendar offset amount (i.e., the difference from the system time).

Note: For details, refer to the "P61: Calendar Module".

## Calendar Offset Editing

Sets how much to offset the calendar module print data from the system clock.



Item	Explanation
Year to Minute	Displays the offset amount from years to minutes from the system clock. The input range is described below. Year: -100 ~ +100      Month: -11 ~ +11 Day: -999 ~ +999      Hour: -11 ~ +11 Minute: -59 ~ +59





Key	Process
	Selects items to be edited, and scrolls the display.
	Increases and decreases the value.
	Enters and deletes values.
[+] [-]	Changes symbols.
(Reset)	Resets the total offset amount from year to minute.
	Sets the details being edited.
	Returns to the previous screen.

## Numbering Module Editing

This screen edits the numbering modules.

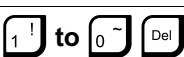

Item	Explanation	Entry Range
Figure	Displays the number of numbering digits.	1 ~ 8
Start	Displays the initial (i.e., start) numbering value.	0 ~ 99999999
Increment	Displays the increments when counting up (or down) the numbering.	-9999 ~ +9999
Stop	Displays the numbering end value.	0 ~ 99999999
Repeat	Displays the number of prints with the same numbering value.	1 ~ 9999
Date Update Reset	Displays whether numbering reset has been set when updating the system clock date.	ON / OFF
Zero Suppress	Displays whether the system has been set to replace digits above a valid number with "0". (That is, replaces with a space when the zero suppression is set to YES.)	ON / OFF

Key	Process
	Selects items to be edited, and scrolls the display.
	Increases and decreases values, and changes the selected item.
	Enters and deletes values.
[+] [-]	Changes symbols. (Valid for increments only.)
	Sets the details being edited.
	Returns to the previous screen.

Note: For details, refer to the "P68: Numbering Module" for the "P49: Registering Numbering Characters".

## Barcode Module Editing

Barcode module editing screen.

```

[ 0123 ] DEL
No.1,ITF
OCR,BR-Bar
Select CodeType Detail End
  
```

Key	Process
F2 (CodeType)	Barcode type to be shown will be changed.
F3 (Detail)	Details of barcode module will be set.

Note: For details, refer to the "P69: Barcode Module".

## Barcode Module Details

Set the barcode module details.

```

Append BR-Bar      OK
BR-Bar Horiz.     [ 4 ]
BR-Bar Vert.      [ 10 ]
Category BR-Bar
  
```

```

Append OCR        OK
Space             [ 1 ]
Omit CD           OK
Category OCR
  
```







```

Append BR-Bar      OK
BR-Bar Horiz.     [ 4 ]
BR-Bar Vert.      [ 10 ]
Category BR-Bar
  
```

```

Start-Char        A
Stop-Char         A
Category S-Char
  
```

Category	Item	Explanation
Barcode	Height	Set the number of the vertical dots for barcode. (Input range : 3 to 26)
	Valid Vertical Dot	Setting is possible only for this range.
	Vertical Dot	The height and the overall barcode height set by OCR setting will be shown.
OCR	Append OCR	Set to print or not to print OCR characters. The OCR characters are always 8 dots. (Select items : YES or NO)
	Space	Set the distance between the barcode and the OCR in terms of the unit of dot. (Input range : 0 to 3)
	Omit CD	Where the CDs designated for ITF, Code 39 or NW7, set to include or not to include CD by OCR. (Select items : YES or NO)
	Divide	Set to divide or not to divide the printing location for OCR designated for ITF. (Select items : YES or NO)
	Omit Start / Stop	Select to omit or not to omit the starting character or the ending character by OCR designated for Code 37 or NW7. (Select items : YES or NO)
	Start / Stop-Char	Select whether the OCR printing of the starting character or the ending character is made in low case. (Select items : YES or NO)
BR-Bar	Append BR-Bar	Set to print or not to print Bearer bar. (Select items : YES or NO)
	BR-Bar Horz.	Set the width of Bearer bar's top and bottom line. (Input range : 0 to 8)
	BR-Bar Vert.	Set the width of Bearer bar's left and right line. (Input range : 0 to 99)
S-Char	Start-Char	Set the start character. (Select items : A, B, C and D)
	Stop-Char	Set the stop character. (Select items : A, B, C and D)

Key	Process
	Selects items to be edited, and scrolls the display.
	Increases and decreases the value.
	Enters and deletes values.
 (Category)	Reclassify the items for setting.
	Sets the details being edited.
	Returns to the previous screen.

Note: For details, refer to the "P69: Barcode Module".





## Interval Module Editing

This screen edits the interval modules.

```
Interval Module 1:
Interval [ 45.0 ]
          0.1~999.9mm
```

Item	Explanation	Entry Range
Interval	Displays the interval distance.	0.1 ~ 999.9

Key	Process
	Increases and decreases the value.
	Enters and deletes values.
	Sets the details being edited.
	Returns to the previous screen.

Note: For details, refer to the "P78: Interval Module".

## Edit Message (Message Selection)

This screen edits the user-defined message numbers.

Detail display

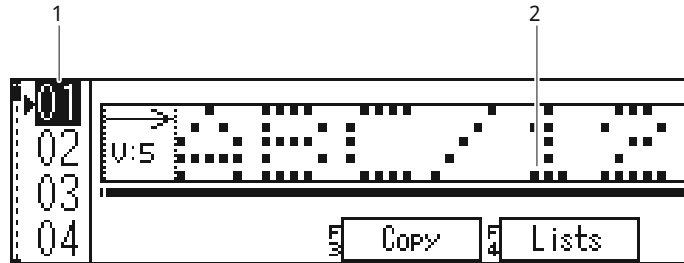

Lists display

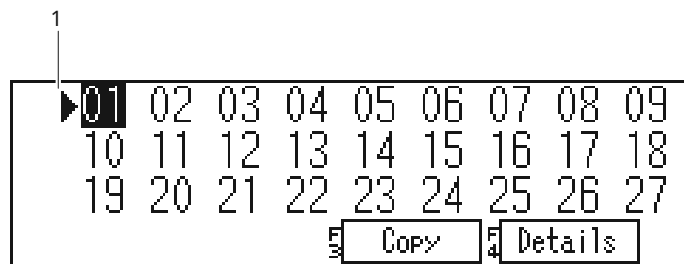

Item	Explanation
1	Displays the cursor and the number of the message selected. The print data are registered to the number displayed as highlighted.
2	Displays the print image for the selected message.

Key	Process
	Scrolls the print image (in advanced display). Selects the message number (in table display).
	Selects the message number.
(Copy)	Copies the details of the selected message number to another number.
(Lists / Details)	Switches the selected message number display.
	Deletes the details of the selected message number.
	Edits the details of the selected message number.
	Returns to the previous screen.

Note: For details, refer to "P39: Selecting Message Numbers".

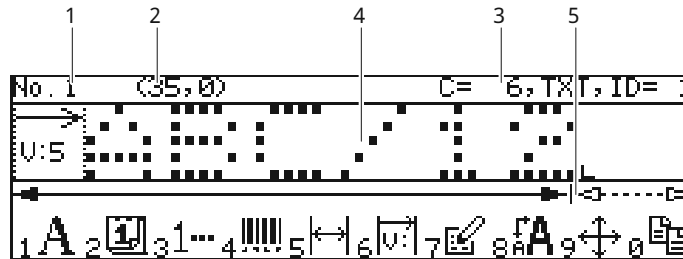

## Message Editing

This screen edits messages.



Item	Explanation
1	Displays the number of the message being edited.
2	Displays the cursor coordinates.
3	From the left <ul style="list-style-type: none"> <li>• Number of characters using the the message being edited (text modules only).</li> <li>• Type of module selected.</li> <li>• Selected module ID. (Reference during communications specifications.) is displayed.</li> </ul>
4	Displays the message print image.
5	The range displayed using the solid arrows describes the print area, and the range displayed using the dotted arrows describes items not registered as messages.

Key	Process
	Moves the cursor. The amount of cursor movement is increased when the  key is also held down at the same time.
	Moves to "text module editing" and registers a new text module.
	Moves to the "special module selection" screen ,and registers a new calendar module.
	Moves to the "special module selection" screen ,and registers a new numbering module.
	Moves to the "special module selection" screen ,and inserts an interval module.
	Moves to the "message layout" screen, and adds a message layout.
	Edits the layout or module selected by the cursor.
	Moves to the "character properties" screen, and edits the properties of the module selected using the cursor.
	Moves to the position of the layout or module selected using the cursor.
	Copies and registers the module selected using the cursor to the user-specified position.

Key	Process
	Deletes the selected layout and module. (If the layout is deleted, the modules within the layout are also deleted.)
	Returns to the previous screen.
	Ends message editing.

\* Icons are not displayed for functions that cannot be operated using the cursor position.

Note: For details, refer to "P40: Registering Fixed Characters".



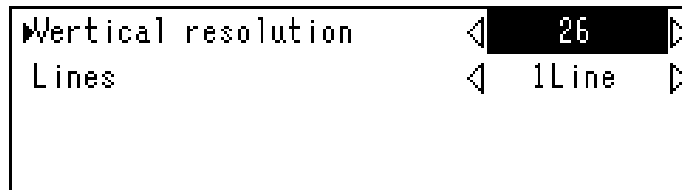

## Message Layout

Edits message layouts.



Item	Explanation
Vertical	Displays the number of scan dots (i.e., the vertical print resolution). (Available values: 26, 24, 22, 20, 16, 15, 12, 11, 10, 9, 7, and 5 dots)
Lines	Displays the number of print lines. (Available values: 1 to 4 lines and free)

As for 11 and 15 dots of the vertical resolution, needs DSP version D2-12-00 later.

Key	Process
	Selects the items to be edited.
	Increases and decreases values, and changes the selected item.
	Enters and deletes values.
	Sets the details being edited.
	Returns to the previous screen.

\*For operations, refer to "P40: Registering Fixed Characters".

## Text Module Editing

Edits and registers text modules.



## Character Properties

Edits the module properties.

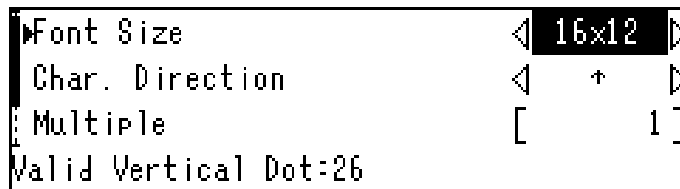

Item	Explanation
Valid Vertical Dot	Only "font sizes" and "character orientation" within this range can be set.
Font size	Describes the character size. (Available values: 24x24, 24x18, 16x16, 16x12, 12x10, 10x8, 9x9, 9x7, 7xN, 7x8, 7x5, 5xN, 5x5 )
Char.Direction	Describes the character orientation. (Available values: , , , mirror)
Multiple	Displays the amount of magnification of characters along the horizontal orientation. (Available values: 1~8)
Char.Space	Displays the space (number of dots) between adjacent characters. (Entry Range: 0 ~ 31)

The "Font Size" that can be selected is limited according to the "Valid Vertical Dot".

As for 7xN and 5xN font size, needs the font data which supported proportional font.

Key	Process
	Selects the items to be edited.
	Increases and decreases values, and changes the selected item.
	Enters and deletes values.
	Sets the details being edited.
	Returns to the previous screen.

For details, refer to "P55: Character / Printing Calibration".

## Config

This screen displays the settings concerning the overall unit.

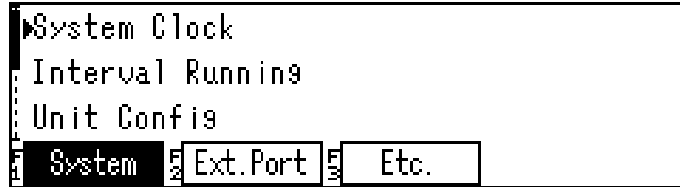

Properties	Item	Explanation
System	System Clock	Moves to the "System Clock" screen.
	Interval Running	Moves to the "Interval Running" screen.
	Unit Config	Moves to the "Unit Config" screen.
	CHG Detect Rectify	Moves to the "CHG Detect Rectify" screen.
	Interspacing Type	Moves to the "Interspacing Type" screen.
	Head heater Config	Moves to the "Head Heater" screen. Note: Displayed if the Head-Heater mounted to the print head.
Ext. Port	Encoder Config	Moves to the "Encoder Config" screen.
	Ph. Sensor Monitoring	Moves to the "Ph. Sensor Monitoring" screen.
	Transmit Config	Moves to the "CTransmit Config" screen.
	I/O Output Condition	Moves to the "I/O Output Condition" screen.
	Priority Management	Moves to the "Priority Management" screen.
Etc.	Calendar Config	Moves to the "Calendar Config" screen.
	Shift-code Config	Move to the "Shift-code Config" screen.
	Replace Char	Moves to the "Replace character Config" screen.
	Operation Config	Moves to the "Operation Config" screen.
	Level Config	Moves to the "Level Config" screen.
	Change Password	Moves to the "Change Password" screen.
	No. Date Renewal	Moves to the "No. Date Renewal" screen.
Barcode Config	Moves to the "Barcode Config" screen.	







Key	Process
	Selects items and scrolls display.
(System)	Displays the selections for the system functions.
(Ext.Port)	Displays the selections for the external I/O functions.
(Etc.)	Displays the selections for other items.
	Determines the selections.
	Returns to the previous screen.

## System Clock

Sets the standard clock for the CCS-R system.

Year	[ 2012 ]
Month	[ 4 ]
Day	[ 17 ]
	2000~ 2099

Item	Explanation
System Clock	<p>Displays the year, month, day, hour, minute, and second. The input range is described below.</p> <p>Year: 2000 ~ 2099            Month: 1 ~ 12            Day: 1 to 31 (Changes depending on the month and leap years.)            Hour: 0 ~ 23            Minute: 0 ~ 59            Second: 0 ~ 59</p>

Key	Process
 	Selects the item.
 to  	Enters and deletes values.
	Registers the system clock. (During registration, the check screen is not displayed.)
	Returns to the previous screen.

## Interval Running

Sets the timer for interval operations.

Further, interval operation is a function that stabilizes the ink temperature and viscosity when the power supply is turned ON and before printing starts to enable stable printing to be performed during actual use. In addition, if the machine is not used for a long period of time, ink solidification can be prevented in the nozzle by using this function.

	Week	ON	OFF	State
1	Mon ~ Fri	07 : 00	10 : 00	YES
2	Mon ~ Fri	00 : 00	00 : 00	NO
	State			1(SUN) ~ 7(SAT)

Item	Explanation
Week (Start Day to End Day)	Displays the day of the week on which interval operations are performed. (Available values: Sun, Mon, Tue, Wed, Thu, Fri, and Sat)
ON	Displayed the time that the power supply is turned ON. (Entry Range: 0:00 ~ 23:59)
OFF	Displays the time that the power supply is turned OFF. (Entry Range: 0:00 ~ 23:59)
State	Displays whether interval operations are turned YES or NO. (Available values: YES, NO)

Key	Process
	Selects items to be edited, and scrolls the display.
	Enters values and selects the day of the week.
	Deletes values.
(State)	Turns ON(YES) and OFF(NO) the selected interval operation.
	Sets the details being edited.
	Returns to the previous screen.

\* Interval operations do not function while the breaker is OFF.

\* If an alarm occurs during interval operation, the power turns off at the OFF time.

- If printing is not performed during interval operations, the power supply will turn OFF automatically while the interval operations are OFF.

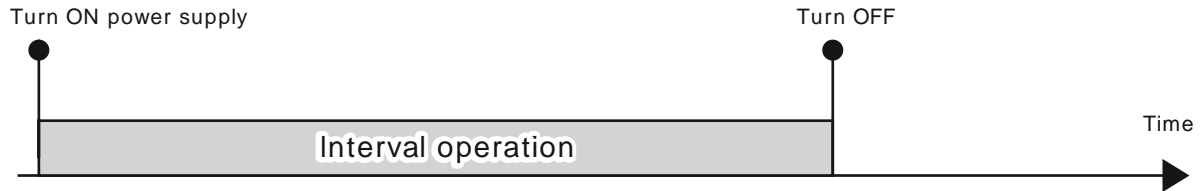

- If printing is performed (or maintenance processing is executed) during interval operations, turning OFF the interval operation will be disabled, and the power supply cannot be turned OFF automatically.

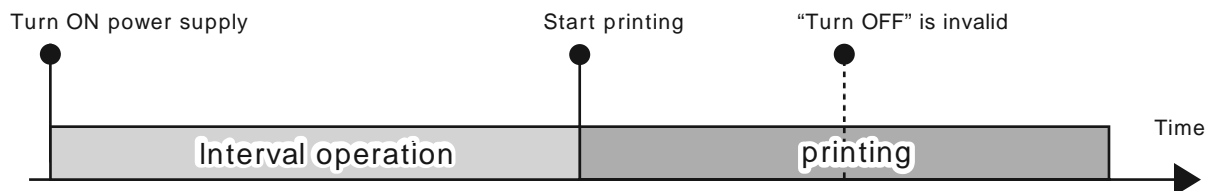





## Unit Config

Sets items that have a low probability of being reset.

One-Shot Print	◀	NO	▶
Print Standby	◀	YES	▶
No-Print Check	◀	No	▶
Tracking Function	◀	NO	▶

Item	Explanation
One-Shot Print	When printing is enable, this function performs printing once only when a print command is entered from the photoelectric sensor. (That is, printing using further print commands is not performed.) If printing again, head operations or the print data settings must be performed again. (Available values: YES, NO)
Print Standby	Displays whether the data can be set during printing. (Available values: YES, NO)
No-Print Check	This function checks whether printing is possible by judging whether poor printing is possible immediately before printing is performed. (Available values: NO, Record, Warning) Record: Makes a record when a no-print occurs, and then performs the next printing. Warning: Sounds an alarm when a no-print occurs.
Tracking Function	This function holds up to six job detections. (Available values: YES, NO)
Ink-Leak Check	This function checks whether the ink is leaking from the ink pump. (Available values: YES, NO)

Note: If the sensor of ink-leak detection un-mounted to ink pump, "Ink-Leak Check" settings will not be displayed.





Key	Process
	Selects items to be edited, and scrolls the display.
	Increases and decreases values, and changes the selected item.
	Enters and deletes values.
	Sets the details being edited.
	Returns to the previous screen.

## CHG Detect Rectify

Adjusts the detection time (note: not the ink droplet) during the start of normal head operations only, but constantly monitors the detection time during operations using this function, and if the tolerances are exceeded, the detection time is compensated to enable stable printing.

Method	Auto
Permissible range	20
	(430~470 [ $\mu$ s])

Item	Explanation
Method	Displays the processing method when the tolerances are exceeded by monitoring the detection time during head operations. (Available values: OFF, Auto, Manual, Interlock, and Variable)
Permissible range	If the detection time tolerances are displayed, and the detection time tolerances are exceeded, an alarm screen to notify that the charge detection time tolerances have been exceeded will be displayed. (Entry Range: Depends on the set value for the charge detection time.)
Adjustment unit	If the compensation method is auto or variable, displays adjustment in microsec. (Entry Range: 0.1 to 5.0)

Key	Process
	Selects items to be edited, and scrolls the display.
	Increases and decreases values, and changes the selected item.
	Enters and deletes values.
	Sets the details being edited.
	Returns to the previous screen.

Compensation Method	Explanation
Auto	If the charge detection time (range) is exceeded, the detection time is adjusted automatically to within range.
Manual	Displays an alarm screen if the detection time exceeds the tolerances. (Printing continues.) Note: "Easy adjustment" using the alarm screen: Adjusts the detection time to within the charge detection time (range). "Complete adjustment": Readjusts the detection time to within the charge detection time.

---

Compensation Method	Explanation
Interlock	<p>Displays an alarm screen and stops printing if the detection time exceeds the tolerances.</p> <p>Note: "Restore" using the alarm screen: Readjusts the detection time to within the charge detection time, and resumes printing.</p>
Variable	<p>Changes the detection time set value and viscosity standard value depending on head temperature and ambient temperature changes, and adjusts the detection time and ink viscosity. (This is a special function, so consult us if using this function.)</p>

---

### ■ Advantages and Disadvantages of Using Detection Time Compensation

Advantages	<p>Even if the detection time is misaligned due to great external temperature changes, a stable print quality can be maintained constantly.</p>
Disadvantages	<p>Print signals entered during detection time adjustment are ignored, causing no-prints to occur.</p> <p>Although occurring randomly, if the intervals between prints is short or during phase adjustment time, or if the charge detection time (range) is narrow, the risk of occurrence increases.</p>

---

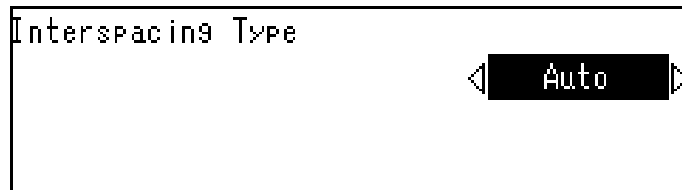

## Interspacing Type

Sets whether to perform "interspacing editing" using the "Print Conditions Editing" screen either manually or automatically.



Item	Explanation
Interspacing Type	Display whether to perform "interspacing" settings manually. (Available values: Manual or automatic)

Note: If the interspacing type is auto, the optimum value obtained from the "Print speed" setting is set as the "interspacing", so manual editing is disabled.

Key	Process
	Changes the selections.
	Sets the details being edited.
	Returns to the previous screen.

## Head heater Config

Sets the operation of heat heater.

Displayed if the head heater mounted to the print head.

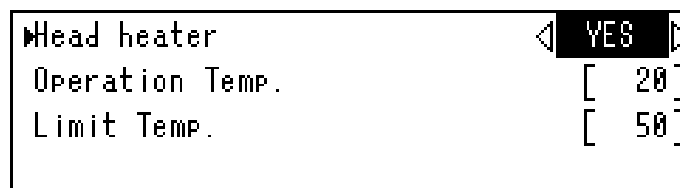

Item	Explanation
Head heater	Displays the head heater control. (Available values: ON, OFF)
Operation Temp.	Displays the operating temperature. (The heater operates when the head temperature falls below this temperature.) (Entry Range: 10 to 100)
Limit Temp.	Displays the limit temperature. (If the head temperature exceeds this temperature, an alarm will sound and printing will stop.) (Entry Range: 10 to 100)

Note: If the Head heater is set to "OFF" the following settings will not be displayed.

## Encoder Config

Sets whether or not to use the encoder, and makes settings regarding rotary encoder operating specifications.



Item	Explanation
Use Encoder	Displays whether or not to use the rotary encoder. (Available values: YES, NO)
Pulse	Displays the number of output pulses per one rotary encoder rotation. (Entry Range: 100 to 10000)
Distance	Displays the line travel distance per one rotary encoder rotation. (Entry Range: 0.1 to 1000.0)
Rotation Direction	Displays the rotary encoder rotation direction. (Available values: CW: Clockwise; CCW: Counter-clockwise)
Photo Check	Enables settings concerning the messages "Repeat printing: "ON" and repeat method : "ON" in the "Print Conditions" screen. OFF: Printing continues so long as there is remaining print data even if the photoelectric sensor is turned OFF. ON: Prints only while the photoelectric sensor is turned ON, and all print data remaining when the sensor is turned OFF is discarded.

Key	Process
	Selects items to be edited, and scrolls the display.
	Increases and decreases values, and changes the selected item.
	Enters and deletes values.
	Sets the details being edited.
	Returns to the previous screen.

If the number of pulses and distance per rotation have been set, make sure the following conditions are satisfied.

$$\frac{(\text{No. of pulses per rotation}) \times 4}{(\text{Distance (mm) per rotation}) \times 10} = 2$$

If this condition cannot be satisfied, use a high resolution rotary encoder or reduce the pulley diameter, etc., and select a rotary encoder that increases the number of output pulses when a fixed distance has been traveled.

## Photo Sensor Monitoring

If the head is operating, sets whether the print command signals from the photoelectric sensor output an alarm if the sensor is ON for longer than a set period. (This is to prevent malfunctions such as no-printing if the object being printed upon stops in front of the photoelectric sensor, or if the photoelectric sensor is dirty, etc.)

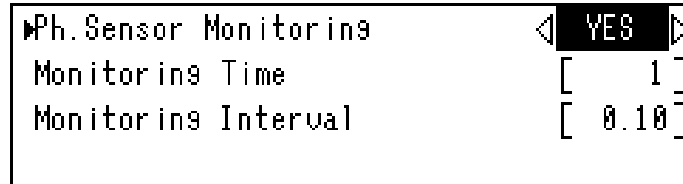

Item	Explanation
Ph.Sensor Monitoring	Displays whether the continuous ON time of the print command signals is monitored. (Available values: OFF, ON)
Monitoring Time	Displays the continuous ON time of the print command signals. An alarm sounds if the print command signals continuous ON time is exceeded. (Entry Range: 1 to 3600 [second])
Monitoring Interval	Displays the interval to monitor the photoelectric sensor output. Change the data when turning off of the photoelectric sensor output is not detect. Set 0.01 under normal conditions. (Entry Range: 0.01 to 0.50 [second])





Key	Process
	Selects items to be edited, and scrolls the display.
	Increases and decreases values, and changes the selected item.
	Enters and deletes values.
	Sets the details being edited.
	Returns to the previous screen.

## Transmit Config

Sets the communications conditions.

Baud Rate	◀	9600	▶
Char. Length	◀	8bits	▶
Parity	◀	No	▶

Item	Explanation
Baud Rate	Displays the baud rate. (Available values: 4800, 9600, 19200, 38400, 57600, and 76800)
Char. Length	Displays the character length. (Available values: 7 bits and 8 bits)
Parity	Displays the parity check. (Available values: NO, odd, even)
Stop Bit	Displays the stop bit. (Available values: 1 bit and 2 bits)
Error Form	The format of the error response returned from the CCS-R if an error occurs in communications to the CCS-R from the host device such as a PC, etc. (Available values: NAKerror code, or NAK)
Check Sum	Displays whether or not check sum processing is performed during communications. (Available values: ON, OFF)
Print End Signal	Displays whether to output a print end to the host machine whenever printing has ended. (Available values: ON, OFF)

Key	Process
	Selects items to be edited, and scrolls the display.
	Changes the selections.
	Sets the details being edited.
	Returns to the previous screen.

## I/O Output Condition

Sets the output conditions for the I/O output "ready signal" (i.e., printing is possible) and "printing".

```

Condition of ready signal
▶Printing disable          ◀ ON ▶
Printing&Waiting         ◀ ON ▶
Preparing for the data   ◀ OFF ▶
  
```

Item	Explanation
Printing disable	Displays the status of switches 1 to 3 in the following diagram.
Printing & Waiting	
Preparing for the data	

### ■ “Ready” Signal Output Conditions

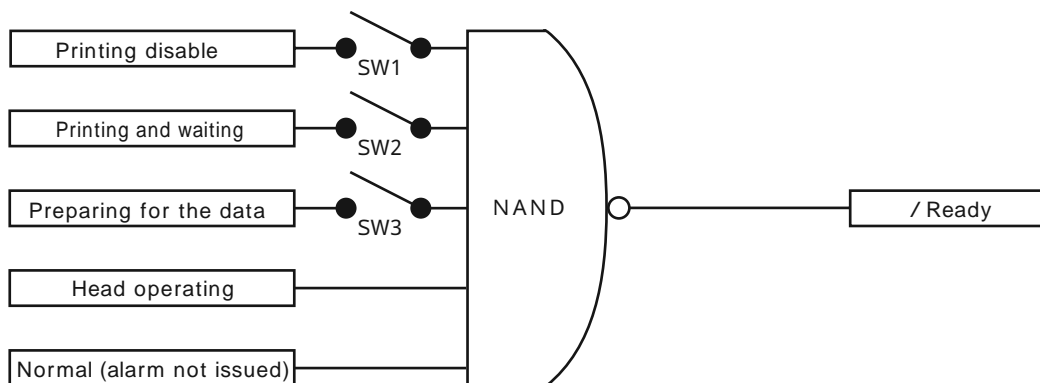

---

## Priority Management





If any keys are operated while communications with the host device such as a PC are being processed, processing may be delayed or not performed. (If the processing interval is approx. 0.5s or greater, there is no problem.)

To improve this situation, this screen sets the processing priorities.

(If the processing interval is less than 0.5s, setting to "priority processing" is recommended.)



Item	Explanation
Communications	<p>Describes the communications processing priority. (Available values: Normal and Priority)</p> <p>Normal: Processing is performed within 0.5sec of a command being received.</p> <p>Priority: Processing is performed within 5ms of a command being received.</p>





Key	Process
	Selects the items to be edited.
	Changes the selections.
	Sets the details being edited.
	Returns to the previous screen.

## Calendar Config

This screen settings related to the calendar module. (These are not reflected in the system clock.)



Item	Explanation
Week Config	Displays the start and end days of the week used to calculate the week number.
PM Change Time	Displays the time of the switchover from AM to PM.
Calculation date	Displays the processing method if the result of the calendar module offset that has been calculated is a non-existent date.
Start of week number	Displays the first week of the week number.

Key	Process
	Selects items to be edited, and scrolls the display.
	Increases and decreases values, and changes the selected item.
	Enters and deletes values.
	Sets the details being edited.
	Returns to the previous screen.

## Shift-code Config

This screen settings related to the shift-code.



Item	Explanation
1	From the left <ul style="list-style-type: none"> <li>Selected shift-code No.</li> <li>Number of shift-code.(Number of partitions) is displayed.</li> </ul>
2	Displays the start time of selected shift.
3	Displays the selected shift, previous one and next one.
4	Displays the printing contents of selected shift.

Key	Process
	Selects the shift No, scrolls the display, and selects the start time of shift.
	Enters and deletes the start time of shift.
(Addition)	Adds a new shift after selected one.
(Delete)	Deletes the selected shift.
(Edit Cont)	Edits the printing contents of selected shift.
(C.Length)	Edits number of characters (Length of printing contents) .
	Sets the details being edited.
	Returns to the previous screen.

## Operation Config

Performs the operations settings.

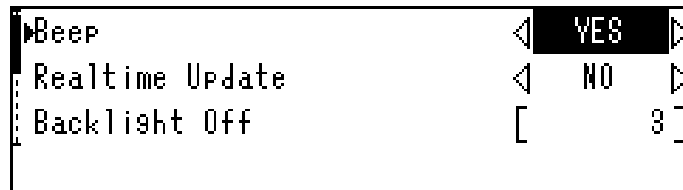

Item	Explanation
Beep	Displays whether the alarm will sound, and whether the keys beep when operated.
Realtime Update	Displays whether to update the calendar and numbering modules in real time for print images on the "Main Menu" screen.
Backlight OFF	Displays how many minutes after the last key was touched that the backlight turns OFF. (Entry Range: 0 to 60; set to 0 for continuously ON.)
Indicate key 1 Indicate key 2	Displays the keys displayed additionally on the "Main Menu" screen while the head is operating. <ul style="list-style-type: none"> <li>• Manual Print: Starts printing manually without print command input.</li> <li>• DispUpdate: Print image is updated even if 'Realtime Update' is set to 'NO'.</li> <li>• Print Disable: Printing is canceled even if the print command is input.</li> </ul>

Key	Process
	Selects items to be edited, and scrolls the display.
	Increases and decreases values, and changes the selected item.
	Enters and deletes values.
	Sets the details being edited.
	Returns to the previous screen.



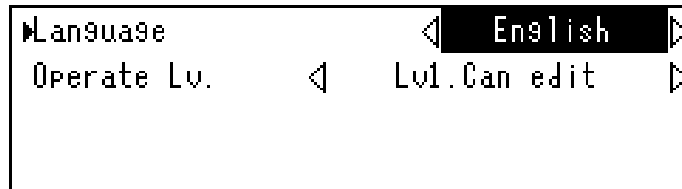

---

## Level Config

Sets the user interface such as display language, etc.



Item	Explanation
Language	Displays the display language. (Available selections: Japanese, Chinese, English)
Operate Lv.	Displays the operations level concerning editing and messages (print data). If changing to a higher operating level, a password must be entered. (Available selections: Lv0.Can't edit, Lv1.Can edit, Lv2.Can all) Lv0.Can't edit: Only switching of message No. is possible. Lv1.Can edit: Switching of message No. , and editing of message contents are possible. Lv2.Can all: All operations are possible.(settings of unique values)

Key	Process
	Selects items to be edited, and scrolls the display.
	Changes the selections.
	Sets the details being edited.
	Returns to the previous screen.

## Change Password

If changing the operating level for messages (print data) and editing to a higher level, a password must be entered. The password can be changed using this screen.

- 1** Select the password to be changed.

```
Select change password.
                                     < Lv1.Can edit >
```

- 2** Enter the current password.

```
Input current password.
                                     [ **** ]
```

- 3** Enter the new password.

```
Input new password.
                                     [ **** ]
```

- 4** Enter the new password again to make sure.

```
For confirmation,
input new password a9ain.
                                     [ **** ]
```

Item	Explanation
Lv1. Can edit (Switching and editing of messages are possible)	Changes the password when the operating level changes.
Lv2. Can all (All operations are possible)	

## No. Date Renewal

Makes the settings concerning resets when the date is updated in the numbering module.

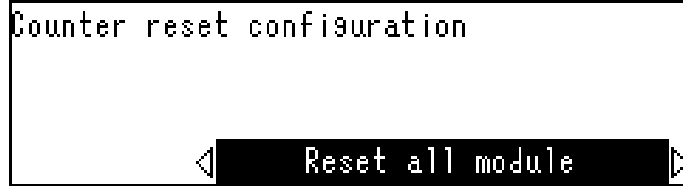

Item	Explanation
Process	Displays the module to be reset when the date is updated. (Available selections: Reset printing module, or reset all module.)
Key	Process
	Selects items to be edited, and scrolls the display.
	Changes the selections.
	Sets the details being edited.
	Returns to the previous screen.

## Replace-character Selection

Character replacement is a function for printing by replacing default characters printed by the numbering and calendar modules with other characters, and which character types to allocate can be selected using this screen.

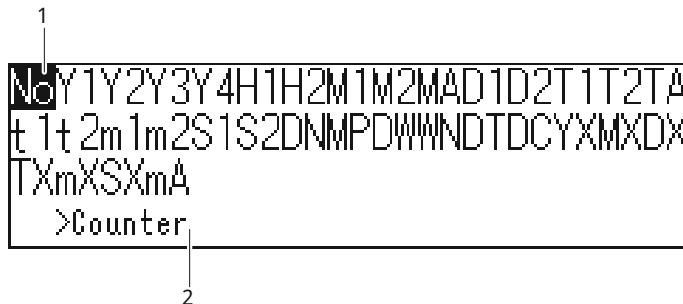

Item	Explanation
1	Selects the character types to be used for replace-character.
2	Displays the character explanation.
Key	Process
	Selects the items to be edited.
	Edits the selected character type.
	Returns to the previous screen.

## Replace-character Edition (1)

Selects one character to be replaced by another character for one character type.

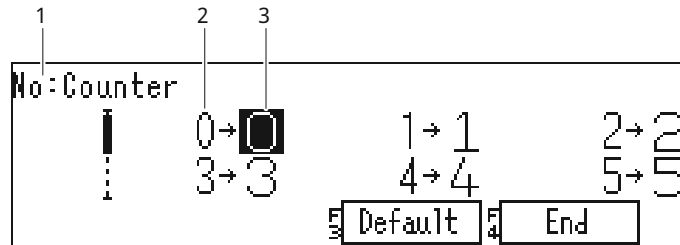

Item	Explanation
1	Displays the type and explanation of character.
2	Displays the character to be replaced.
3	Displays the character after replacement.

Key	Process
	Selects items to be edited, and scrolls the display.
(Default)	Sets the character type currently being edited to the default (initial) values. The details being edited are not registered until the  (End) key is pressed.
(End)	Sets the details being edited.
	Replaces the selected character.
	Returns to the previous screen.

## Replace-character Edition (2)

Edits the replaced character.

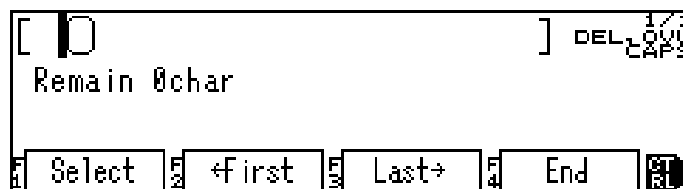

## Barcode Config

Set the Barcode Module blank and bar thickness.



Item	Explanation
First space / Last space	Set the width of space (quiet zone) first and last (left and right) barcode. (Input range : 1 to 300 dots)
Narrower line / Narrow line / Wide line / Wider line	Set width of the line (black bar). (Input range : 1 to 99 dots)
Narrower blank / Narrow blank / Wide blank / Wider blank	Set width of the blank (white bar). (Input range : 1 to 99 dots)
Gap	Set width of the gap between bar-character. Only for Code 39. (Input range : 1 to 99 dots)

Key	Process
	Selects items and scrolls display.
	Increases and decreases values, and changes the selected item.
	Enters and deletes values.
(Kind)	Change type of the barcode for display.
	Determines the selections.
	Returns to the previous screen.

## Service

Displays items concerning status and maintenance, etc. of the machine

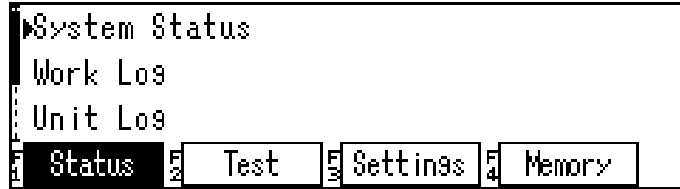

Properties	Item	Explanation
Status	System Status	Moves to the "System Status" screen.
	Work Log	Moves to the "Work Log" screen.
	Unit Log	Moves to the "Unit Log" screen.
	Measurement Log	Moves to the "Measurement Log" screen.
	Exp. Management	Moves to the "Exp. Management" screen.
Test	Unit Test	Moves to the "Unit Test" screen.
	Forced Print	Moves to the "Forced Print" screen.
	Bleed Process	Moves to the "Bleed Process" screen.
	Forced mixing	Moves to the "Forced Churning" screen. Note: Displayed if this is the unit for pigment ink.
	Recirculation Process	Moves to the "Aging Process" screen.
	Draining Process	Moves to the "Draining Process" screen.
	I/O Test	Moves to the "I/O Test" screen.
Settings	Head Parameter	Moves to the "Head Parameter" screen.
Memory	Load backup	Reads the previously-saved backup to memory.
	Save Backup	Backs up the current memory contents.





Key	Process
	Selects items and scrolls display.
(Status)	Displays the selections for the status and history functions.
(Test)	Displays the selections for the test functions.
(Settings)	Displays the selections for the settings functions.
(Memory)	Displays the selections for the memory functions.
	Determines the selections.
	Returns to the previous screen.

## System Status

This screen displays the status of the DIP switches on the PCB mounted to the unit and the versions of the system software, DSP software, and font versions installed in the CCS-R.

```

System soft: 2.14.00
DSP soft: D2-12-00
Charge data: C0-07-50
Data Ver.  Dip Sw.
  
```

Key	Process
	Scrolls the display
 (Data Ver.)	Displays the version of the software and data installed.
 (Dip Sw.)	Displays the DIP switch status.
	Returns to the previous screen.





## Work Log

Displays the history of the times that the unit power supply was turned ON and OFF, and the times an error occurred, etc.

```

No.      Date                CODE
1  2012/04/17-08:29.06    1100
2  2012/04/16-20:03.31    1110
3  2012/04/16-19:49.18    1100
4  2012/04/16-19:48.37    1110
New      Old      Code
  
```

Item	Explanation
No	A maximum of 256 incidents can be stored in the history log.
Date	Displays the date and time of the recording.
CODE	Displays the history code.



Key	Process
	Scrolls the display.
 (New)	Displays the latest history (No. 1).
 (Old)	Displays the oldest history record saved.
 (Code)	Displays the 'History code reference'.
	Returns to the previous screen.

## History Code Reference

This screen displays and explanation of the codes for the histories in the "Operations History" screen.

```

1100 Power on
1110 Power off
1120 Run
1130 Stop
  
```

Key	Process
	Scrolls the display.
	Returns to the previous screen.





## Unit Log

This screen displays the power ON time, operating time, and number of prints to date for the unit.

```

Turn ON Time          30.8
Print Time            [ 2.5 ]
Print Count           [ 0 ]
  
```

Item	Explanation
Turn ON Time	Displays the power ON time to date.
Print Time	Displays the operating time (head operating time) to date.
Print Count	Displays the number of prints performed to date.
GOC Time	Displays the number of times the gutter has been opened and closed.

Key	Process
	Selects items to be edited, and scrolls the display.
	Increases and decreases the value.
	Enters and deletes values.
	Sets the details being edited.
	Returns to the previous screen.







## Measurement Log

Displays the history of the viscosity measurements.

No.	Log Time	U.Temp.	Visc	Refill
1	04/17-09:03	25.1	100.0	0
2	04/16-19:26	25.1	100.0	35
3	04/16-19:25	25.1	29.48	35

[-90] [F2] [+90] [F3] Update [F4] Average [F5]



Item	Explanation
No	A maximum of 500 events can be stored in history.
Log time	Displays the measuring time.
U.Temp	Displays the unit temperature.
Fall	Displays the drop time (ink viscosity).
Refil	Displays the time that the viscosity measurement tank was filled with ink.
Solv	Displays the number of times the solvent has been replenished until the next measurement.
H.Temp	Displays the head temperature.
Detect	Displays the charge detection time.
Piezo	Displays the D/A command value (the value of 1/16) for the Piezo voltage.

Key	Process
	Displays the history in numerical order using a vertical scroll.
	Displays the measurement items using a horizontal scroll.
 (-90)	Scrolls the history 90 events at a time towards the newest events.
 (+90)	Scrolls the history 90 events at a time towards the oldest events.
 (Update)	Updates the history with the newest events.
 (Average)	Displays the average values for the viscosity measured today.
	Returns to the previous screen.

## Exp. Management (1)

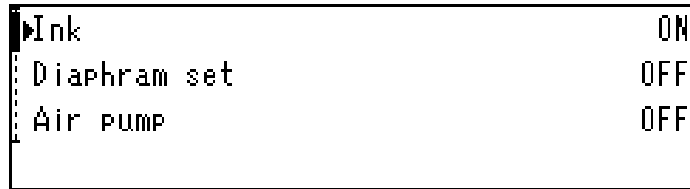
Selects items for the management of consumables.



Key	Process
	Selects items to be edited, and scrolls the display.
	Edits the consumables information for the selected items.
	Returns to the previous screen.





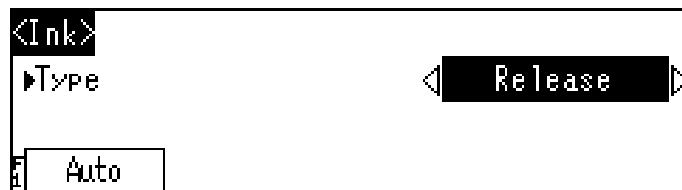

Note: For consumables management, refer to "P86: Consumables Management".

## Exp. Management (2)

Performs consumables management settings for each item.





Item	Explanation
Type	Displays the consumables management method. (Available selections: Release, Date, Cumulative, Counts, Monthly, Weekly, and Dayly. )
[Type : Date] Year, Month, Day	Displays the date to give warning.
[Type : Cumulative] Hours	Displays the operating time to give warning.
[Type : Counts] Counts	Displays the number of gutter open/close to give warning.
[Type : Monthly] Day	Displays the day to give warning monthly.
[Type : Weekly] Week	Displays the week to give warning weekly.
Contents	Displayed when 'Free1' or 'Free2' item is selected to show the content of consumable.



Key	Process
	Selects the items to be edited.
 (Auto)	Sets the management method and replacement time automatically. (The edited details are not saved until the  key is pressed.)
 (Contents)	Displayed when 'Free1' or 'Free2' item selected to edit the content of the consumable. (The edited details are not saved until the  key is pressed.)
	Sets the details being edited.
	Returns to the previous screen.

Note: For consumables management, refer to "P86: Managing Consumables".

## Forced Print

Enables printing using control panel operations even if no print commands have been entered.

Method	Speed	Use Encoder
Print1	Cur.set.	Cur.set.
Print2	1m/min	No use
 Print1	 Print2	

Key	Process
 (Print 1)	Prints using the "Rotary Encoder Settings" and "Print Conditions" screens. (Enabled only when the head is in operation.)
 (Print 2)	Performs printing at a print speed of 1m/minute without using an encoder. (Enabled only when the head is in operation.)
	Returns to the previous screen.

## Bleed Process

This screen expels air from the tubes. And, displays the unit operating status.

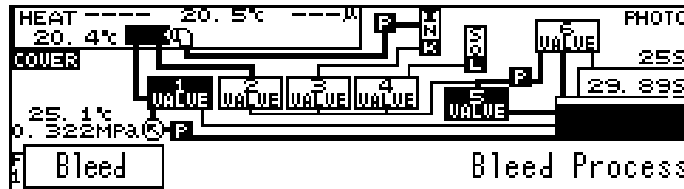

Key	Process
(Bleed)	Starts and stops the bleed processing. (The display during processing is highlighted.)
	Returns to the previous screen. (Stop the bleed processing)

Note: About the display of the unit operating status, refer to "P94: Unit Information".

## Forced mixing

This screen churns pigment ink. And, displays the unit operating status.

(Displayed if this is the unit for pigment ink)

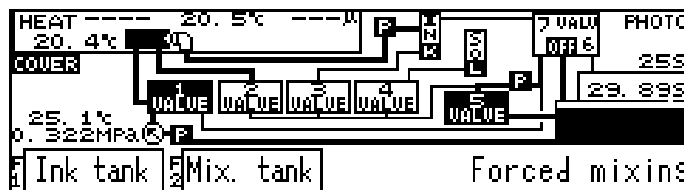

Key	Process
(Ink tank)	Starts and stops the churning processing of ink tank. (The display during processing is highlighted.)
(Mix. tank)	Starts and stops the churning processing of mixture tank. (The display during processing is highlighted.)
	Returns to the previous screen. (Stop the churning processing)

Note: About the display of the unit operating status, refer to "P94: Unit Information".

## Recirculation Process

This screen normalizes fluids (i.e., removes air and dust) circulating within the pipes. And, displays the unit operating status.

Screen of operating status

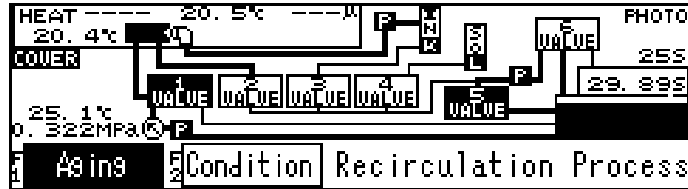

Screen of editing condition



Item	Explanation
Nozzle	Displays the type of nozzle mounted to the ink jet. Aging : A large-caliber nozzle specifically for performing aging. Normal : A nozzle used by the customer for printing.
Refill solvent	Sets the interval (in period) to supply solvent. Set 0 under normal conditions. (Entry Range: 0 to 36000; set to 0 for no refill solvent.)
Key	Process
	Selects items to be edited, and scrolls the display.
	Changes the selected item.
(Aging)	Stops and starts the aging process. (The display during processing is highlighted.)
(Condition)	Displayed during aging. Edits the conditions of aging (i.e., select the type of nozzle mounted to the ink jet).
	Returns to the previous screen. (During aging, the process continues even if the display is returned to the previous screen.)

**Note:** During aging, the display cannot be changed to head operations status.

## Draining Process

Drains ink and solvent from the tanks.

- 1 Selects the tank to be drained.

```
Process of drain ink, at trans
port and ink-exchange.

◀ Drain all ▶
```

- 2 A check message is displayed.



```
Take off a drain stopper,
Insert tube in empty bottle.

Ent)Start drain          Esc)Cancel
```

- 3 Perform discharge according to the on-screen instructions.

```
Drain... : Mixture tank

Ent)Pause                Esc)Quit
```

Key	Process
	Changes the selections.
	Starts the discharge.
	Returns to the previous screen.

---

## I/O Test

This screen checks the output operations to external devices by enabling the user to turn ON and OFF the I/O connector output signals at will.







Key	Process
	Selects the test item.
	Turns ON and OFF the signal status.
(Test)	Switches to test mode. (While in test mode, highlight this function.)
	Returns to the previous screen.

## Head Parameter

Sets the print-related head items.

Deflect Voltage	[ 170 ]
Charge Detect Time	[ 450 ]
Band	[ 10 ]
	0 ~ 255

Item	Explanation
Deflect Voltage	Displays the voltage output to the biased poles using digital command values. (Entry Range: 0 to 255)
Charge Detect Time	Displays the ink droplet adjustment value using the time from ink droplet electrification to passing through the detector electrode. (Entry Range: 200 to 600)
Band (Bandwidth of charge detect time)	Performs compensation if the detection time compensation function is operating to keep within the set range. (Entry Range: 0 to 100)
Sampling Count	This is the number of data samples that are used in adjustments during phasing (i.e., ink droplet adjustment). (Entry Range: 10 to 200)
Piezo Step	This is the number of Piezo digital command value steps during detection time compensation. (Entry Range: 1 to 30, default value is 3.)
Piezo Frequency	The Piezo motor frequency. (Selectable Range: 64KHz, 73.5KHz, 80KHz, or 96KHz)
Season Mode	This mode prevents ink droplet warping defects due to changes in external temperature. (Available selections: ON, OFF)

Key	Process
	Selects items to be edited, and scrolls the display.
	Increases and decreases values, and changes the selected item.
	Enters and deletes values.
	Sets the details being edited.
	Returns to the previous screen.

### Caution

This screen settings is an extremely important value for printing, so if changing the set value please consult us.



# 7 Inspection and Maintenance

To use the device in a satisfactory condition for a long time, and to maintain a satisfactory quality at all times, make sure to read thoroughly this "7. Inspections and Maintenance", and perform suitable maintenance.

The CCS-R uses an automatic nozzle sealing system with gutters, so there is no worry about nozzle clogging due to hardened ink. Further, stable printing can be maintained at all times by using the automatic viscosity calibration mechanism and the interval timer. In addition, even in the unlikely event that a malfunction such as unstable printing is detected, the malfunction can be repaired extremely easily, and these malfunctions can be prevented by simple daily maintenance.

## Periodic Inspections

Failure to make periodic inspections may cause malfunctions or poor printing. Perform suitable inspections as described below. The items to be inspected are as follows.

Period	Item
Daily Inspections	Check electrode unit and gutter dirt. Remaining ink and solvent amounts, and waste liquid amount of condensate. Check if the insulation tape is peeling off.
Weekly Inspections	Check ink pressure. Check sedimentation of pigment components in the ink tank (pigment ink machine only)
Monthly Inspections	Check extractor air filter and service life

# Daily Inspections

## Checking Electrode Unit and Gutter Dirt

The part that comprises the charge electrode, detector electrode, and deflection electrode is called the electrode unit. If dust adheres to the charge electrode or detector electrode, or they are dirty with ink, ink droplets will not be created correctly, and the warning lamp near the display screen will light, the alarm will sound, and printing will be disabled.

Printing will also be defective if the bias electrode and gutter are dirty with ink.

To check the electrode unit for stain, change to the stop mode, then remove the head cover. For details of cleaning electrode unit, refer to "P163: Cleaning the Electrode Unit".

For details of checking and cleaning the gutter, refer to "P166: Cleaning the Gutter and the Ink Outlet".

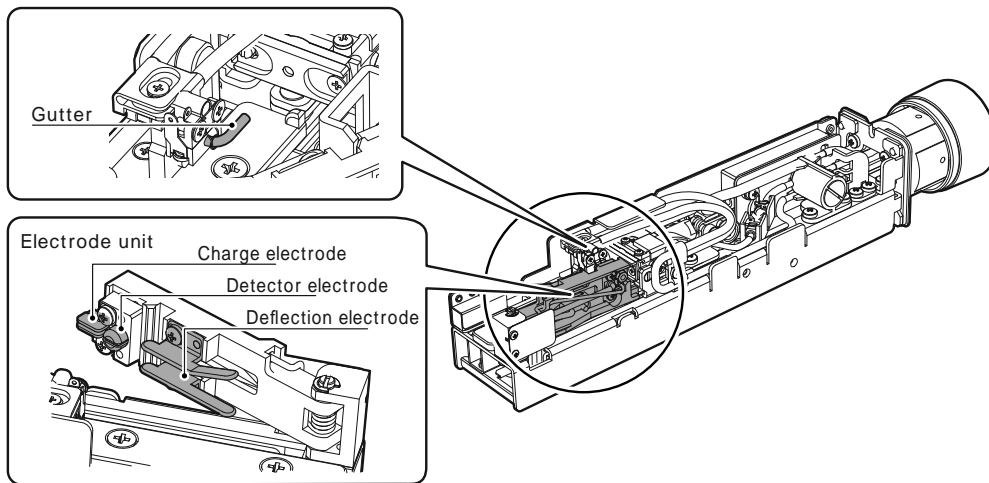

### Checking the Remaining Ink and Solvent Amounts, and Waste Liquid Amounts

It is recommended to check carefully the remaining amount in the ink and solvent tanks to make sure that the ink and solvent do not run out during operation. If the ink and solvent should fall below the required amount, the ink lamp on the control panel will light, and an alarm will sound. Replenish the ink and solvent promptly. The ink and solvent can also be replenished while the device is operating.

For detailed check and replenishment methods, refer to "P186: Replenishing Ink and Solvents"

The solvent included in exhaust is gradually stored in the condensate tank. Do not use this waste liquid again as solvent because it includes much moisture in air, etc.

For detailed check and disposal methods, refer to "P188: Disposal the Waste Liquid".

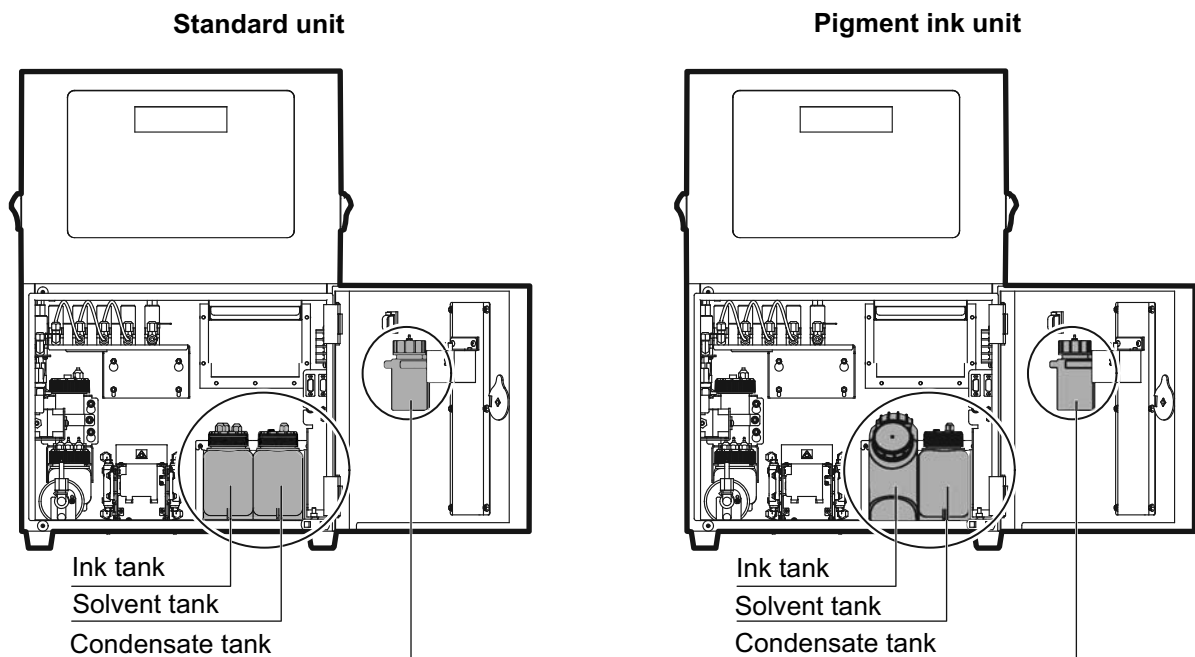

### Service Life

There is a service life to the ink depending on the specific ordinary environment. Using ink that has exceeded its service life may make obtaining normal print quality impossible. Replace with new ink even if the amount of ink used is small, and has not been all consumed by the expiration date.

For expiration date of ink or solvent, refer to description on bottle label.

#### Reference

- The solvent depends on the use environment, but on average approximately 1L is consumed per every 110 hours.  
This is only a benchmark using average print conditions, however, so manage according to individual use conditions.

---

## Checking the Isulation Tape Inside the Head Cover

The insulation tape prevents leakage of high voltage from deflection electrodes to the head cover. Check if the insulation tape is peeling off when opening the head cover in daily maintenance. Before peeling of the tape worsen, order replacement of the insulation tape to the nearest sales office.

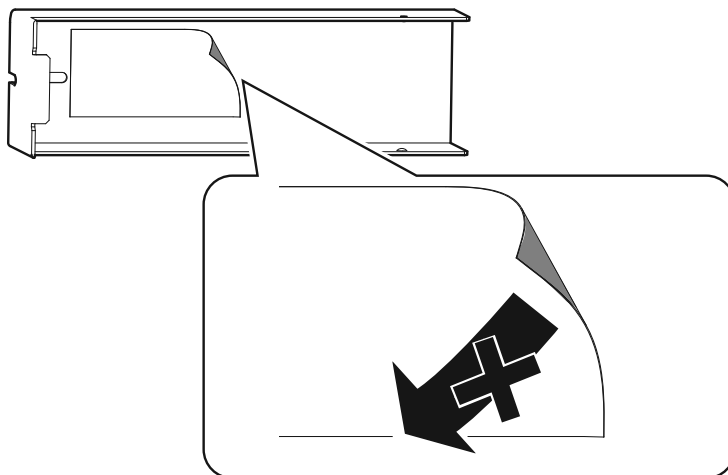

### CAUTION

- Do not remove the insulation tape, even if it is peeling off.  
Leakage of the high voltage would cause defective printing and may occur or inside of printhead may be stained with ink.

## Weekly Inspections

### Checking Ink Pressure

If the ink pressure falls, correct ink droplet creation will be disabled, causing poor print quality and an alarm to sound. Pay constant attention to the pressure value shown on the pressure display (i.e., the display in the unit test).

For details, refer to "P189: Adjusting Ink Pressure".

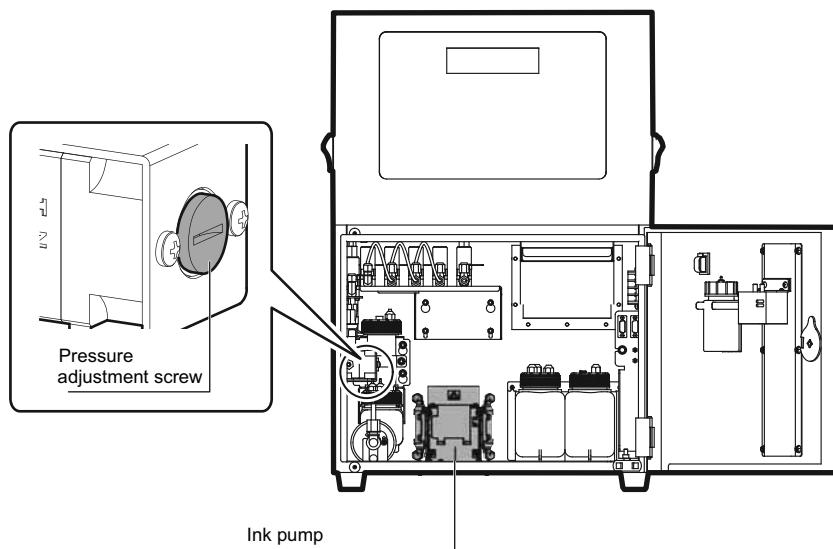

If the pressure does not rise even if the pressure adjustment screw has been turned, the cause may be one of the following.

- Jammed ink filter
- Jammed pipes

In such times, it is necessary to replace the ink filter (see "P192: Replacing the Ink Filter", and to clean inside the pipes.

### Check Sedimentation of Pigment Components in the Ink Tank

In the pigment ink machine, if the pigment components in the ink tank settle, printing may become light and viscosity may become abnormal. Check that there is no sediment on the bottom of the tank. If there is sediment, stir well with a stirrer.

---

# Monthly Inspections

## Checking the Extractor Air Filter

There is an extractor fan in the center of the CCS-R main unit. These fans suck air from the outside into the unit, and vent from the bottom of the unit. Although also dependent on the environment, clean or replace the filter approximately once a month. Cleaning can be performed using an ordinary commercial vacuum cleaner. Perform inspections more frequently in sites where the airborne dust is particularly great, such as when processing wood. For details, refer to "P196: Cleaning and Replacing the Extractor Air Filter".

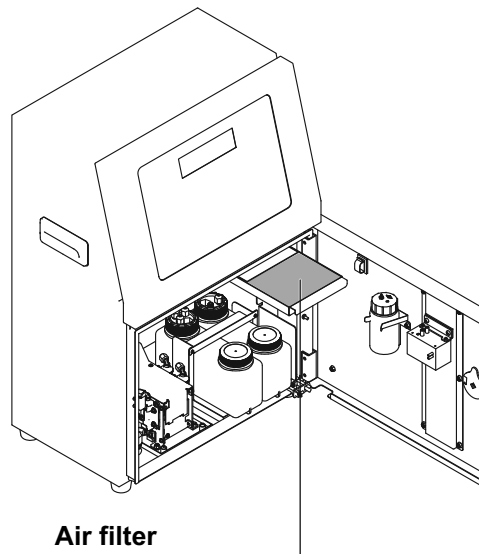

## Checking Service Life

Check the service life of the following items.

Replace if the service life has expired. For details, refer to the relevant replacement method. If the ink pump service life has expired, factory repairs are necessary, so please contact us.

Product Name	Replacement Period	Reference
Head filter	3,000 hours(Turn ON time), or when it is clogged	Refer to "P182: Replacing the Head Filter".
Nozzle gasket	1,000 hours(Turn ON time), or the gutter has been closed 2,000 times, or if damaged	Refer to "P179: Replacing the Nozzle Gasket in the Nozzle Palette".
Ink pump	12,000 hours(Turn ON time)	Contact us
Diaphragm unit or Diaphragm set	Dye ink : 12,000 hours(Turn ON time) Pigment ink : 2,000 hours(Turn ON time)	Refer to "P201: Replacing the diaphragm unit".
Ink filter	The following expiration date, or when it is clogged Dye ink : 3,000 hours(Turn ON time) Pigment ink : 1,500 hours(Turn ON time)	Refer to "P192: Replacing the Ink Filter".
Large circulation filter	1,500 hours(Turn ON time), or when it is clogged	Refer to "P194: Replacing the Large Circulation Filter".
Air pump	4,000 hours(Turn ON time), or if damaged	Refer to "P198: Replacing the Air Pump".
Backup battery	1.5 years	Refer to "P200: Replacing the Backup Battery".

The rate of deterioration of parts depends on the usage frequency or operating time or usage environment . Replacement period is only an estimate.

Some of the above item are not in use for some models. For details, refer to "Ink compatibility table".

---

## Inspecting Under Harsh Conditions

The above description does not apply to the required frequency of periodic inspections under particularly harsh or adverse environments such as high and low temperatures, high humidity, water vapor, or dust, etc. Perform the daily inspections frequently and with close attention if using under harsh conditions. For details of the inspection methods, refer to "P148: Daily Inspections".

## Attention to Stopping Pigment Ink Unit

If the pigment ink machine is left idle, there is risk that the pigment in the ink will settle and cause the machine to malfunction. To prevent this, use interval operation to start up the machine each day. Refer to "P116: Interval Running" for detail settings regarding interval operation. The standard is power on for at least one hour per day. If interval operation cannot be used, the machine must be started up after taking the following measures in accordance with the idle period.

Idle period	Measures
2-6 days	Turn on the power 2 hours before operation begins.
7 days or more	Using the stirrer, mix the pigment that has settled on the bottom of the tank. Then, stir the ink for 1 hour in tank stir mode. After that, leave the machine with the power on for at least 2 hours, and then begin operation. If print density seems light, leave the machine with the power on for another few hours, and then begin operation. Refer to "P141: Forced Churning" for information about tank stir mode.
1 month or more	Drain the ink and replace with solvent before leaving the machine idle. For information on replacing the ink with solvent, refer to "P204: Long-term Storage of Pigment Ink Machine." For information on restarting the machine, refer to "P206: Pigment Ink Machine Restart after Long-term Storage"

\* If the machine will be idle for one month or more, please contact our service personnel beforehand.

## Maintenance

The work described above are merely the important basics required for daily inspections and various adjustments. Unless these work methods are learned, normal daily operation of the device will not be possible. Make sure to learn the following work methods.

### Warning

- Take care while working that no ink, solvent, or cleaning fluid adheres to the skin or enters the eyes. If any solutions should contact the skin, wash thoroughly with water and soap. If any solutions enter the eye, thoroughly irrigate the eye with water, and seek medical attention. For details, refer to the SDS for the ink and solvents used.
- Make sure to wear rubber gloves for work in which solvent may contact the hands.

# Screens Used in Maintenance Work

The following two screens are used frequently in maintenance work.

Further, the screen images depend on the type, but the contents are the same, so use the same processing words.

**Unit information** Displays the current CCS-R status in real time. If this screen is displayed during operations, there is a risk that the internal processing cannot be determined and no-printing will occur. Be careful. Further, the units can also be controlled individually by pressing the "Maintenance" button in this screen.

**Unit test** The unit test is divided into input and output screens. The input screen is used to check unit status, and the output screen can control each unit individually.

## Reference

- To display the unit test output screen and the unit information maintenance screen, it is necessary to stop all operations.

## Displaying the Screens

Unit information:

**1** Press the **Ctrl** key.

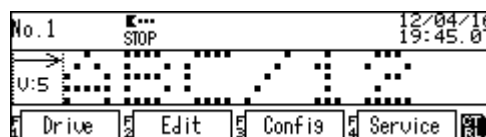

**2** Press the **F3** (Unit Info) key. The unit information screen will be displayed.

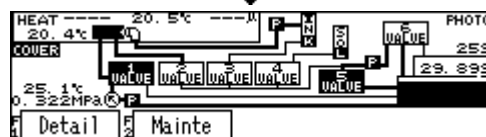
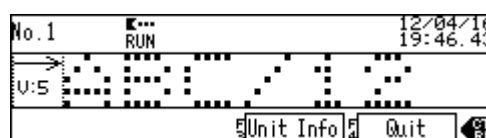

## Unit test (inputs):

- 1** Press the **Ctrl** key.
- 2** Press the **F3** (Unit Info) key.
- 3** Press the **F1** (Detail) key. The unit test (Inputs) screen will be displayed.

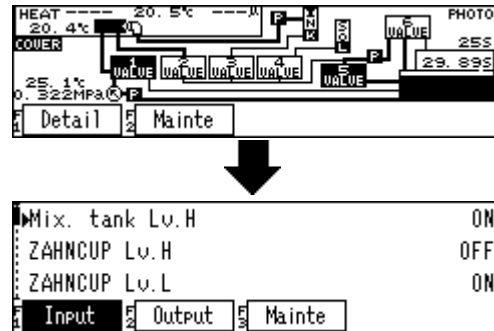

## Unit test (outputs):

- 1** Press the **Ctrl** key.
- 2** Press the **F3** (Unit Info) key.
- 3** Press the **F1** (Detail) key.
- 4** Press the **F2** (Output) key.
- 5** Press the **F3** (Mainte) key. The unit test (Outputs) screen will be displayed.

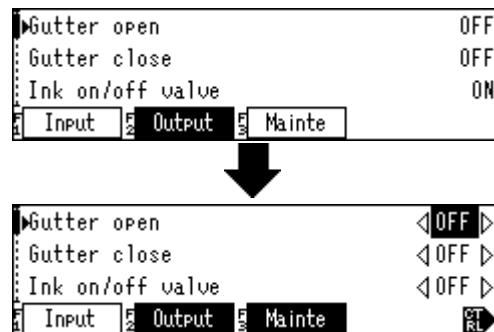

## Unit Information Screen

Displays the status of the sensors and valves, etc., in the unit.

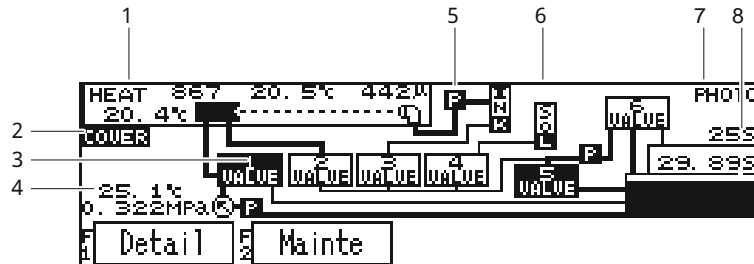

Item	Explanation
1	<p>From top left</p> <ul style="list-style-type: none"> <li>• Head heater ON/OFF status</li> <li>• Piezo voltage (command value)</li> <li>• Head temperature</li> <li>• Charge detection time ( while head is operating only)</li> </ul> <p>Bottom</p> <ul style="list-style-type: none"> <li>• Displays the head heater temperature.</li> </ul>
2	Displays whether the head cover is mounted or removed.
3	Displays the operation status of the valves.
4	(Top):Displays the unit temperature. (Bottom):Displays the ink pressure.
5	Displays the ink pump operation status. (The three pumps operate in union.)
6	Displays whether there is solvent in the solvent tank. (The ink tank display does not change, regardless of whether or not there is ink.)
7	Displays the input status of print commands from the external sensor.
8	(Top): Displays the time to supply ink to the viscosity measuring tank. (Bottom); Displays the ink fall time (i.e., ink viscosity).

Key	Process
(Detail)	Displays the unit test screen.
(Mainte)	Switches to maintenance mode.
	Returns to the previous screen.

In maintenance mode, the gutter, valves, pumps, and head heater, etc., can be operated individually. The display for the part being operated is highlighted.

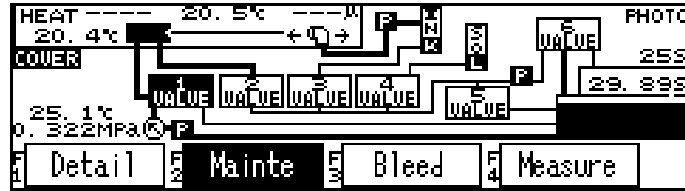

Key	Process
[H]	Turns ON and OFF the head heater.
[P]	Turns ON and OFF the ink pump.
	Opens and closes the gutter. Turns OFF automatically when the gutter is fully open or fully closed.
	Turns ON and OFF the valves. Valves 3 and 4 will not turn ON when the mixing tank is full. (7th valve is displayed only in the case of pigment ink unit.)
	Conducts the bleed processing. (The display during processing is highlighted.)
	Measures the viscosity. (The display during measuring is highlighted.)

\*In maintenance mode, all valves and pumps are turned OFF.

### Reference

- Press (Mainte), and to return to standard mode from maintenance mode.

## Unit Test Screen

Enables sensor inputs to be displayed and valves to be operated individually, etc.

### Input Display

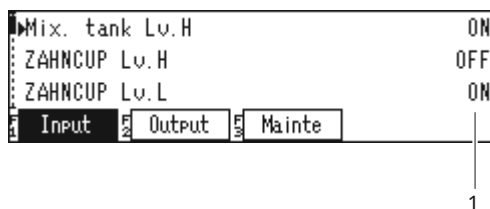

### Output Display

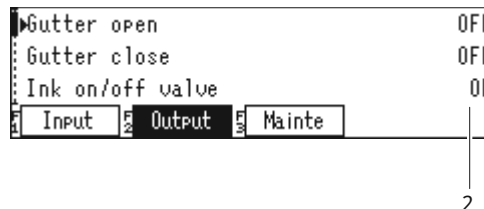

### Output Display--Maintenance Mode

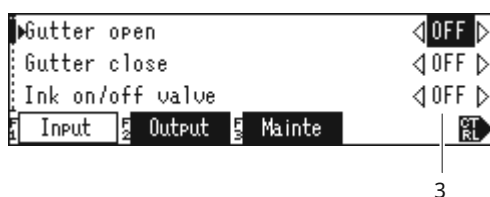

Item	Explanation
1	Displays inputs from the sensors.
2	Displays the operating status of the gutter and valves, etc.
3	Switches to gutter and valve operating status. (Stopped: OFF; Operating: ON)

Key	Process
(Input)	Switches to input display.
(Output)	Switches to output display.
(Mainte)	Switches to maintenance mode.
	Selects items and scrolls display.
	Switches to gutter and valve operating status (in output display and maintenance mode).
	Returns to the previous screen.
	Switches the functions allocated to the keys  to .
(Bleed)	Conducts the bleed processing. (The display during processing is highlighted.)
(Measure)	Measures the viscosity. (The display during measuring is highlighted.)

# Print Head Maintenance

## Mounting and Removing the Head Cover

If performing maintenance on the head, the head cover must be removed. This section explains how.

### ■ Removal

Remove the head from the stand, and place the head in the enclosed parts container before removing the head cover.

**1** Press down part A on the head cover using a finger, and slide the head along the cover slide.

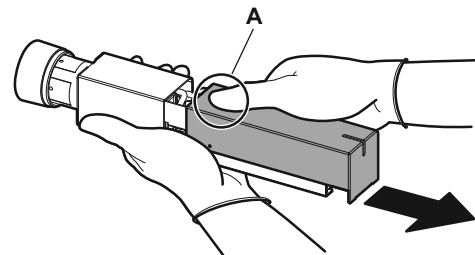

**2** Grasp part B with both hands, and remove the cover.

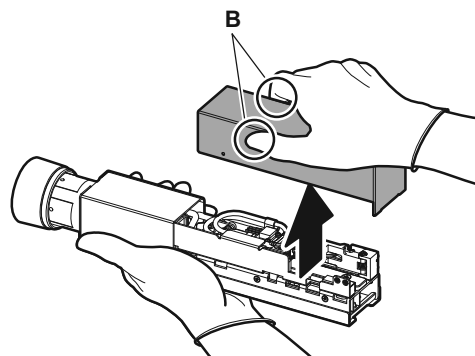

### ■ Mounting

**1** Align the back of the head cover to the front of the head, and slide in the opposite direction from the direction of the head cover slide.

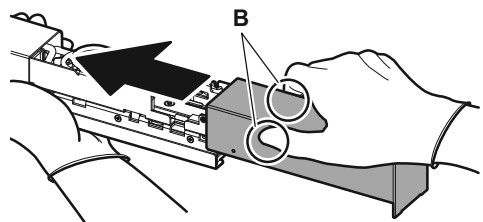

**2** Grasp part B with both hands, and slide the cover.

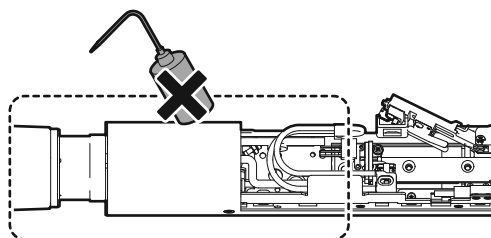

### ⚠ Caution

- Make sure not to pinch the electrode unit cable.
- The head may need to be warmed using a heater depending on the type of ink. Take great care in handling during this time.
- After removing the head cover (on the cable side), do not pour the solvent directly. Doing so may cause a malfunction.

---

## Fixing the Electrode Unit

If performing head maintenance, it may be necessary to fix the electrode unit in an open position before work can start. This section explains how.

### ■ Fixing Method

- 1** Fully open the electrode unit using a finger.

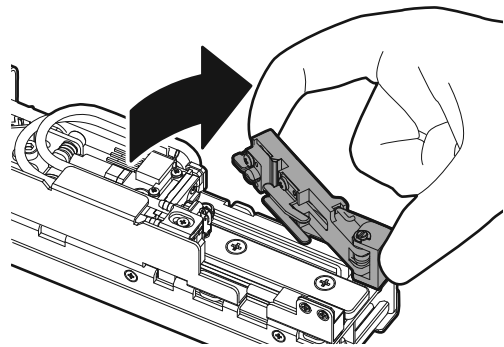

- 2** Holding open the electrode unit using your fingers, insert the electrode fixing jig into the electrode fixing jig hole.

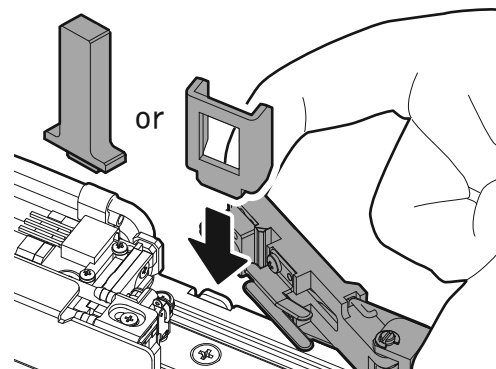

- 3** Gently remove your fingers. The electrode fixing jig will hold the electrode unit in place.

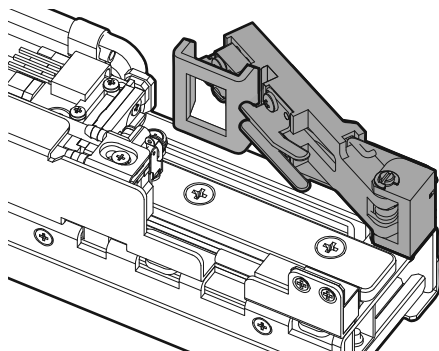

### ■ Removing the Stopper

- 1** Hold the electrode unit fully open using a finger.
- 2** Holding the electrode unit fully open, remove the electrode fixing jig from the electrode fixing jig hole.
- 3** Gently remove your fingers.

## Cleaning the Electrode Unit

The work described here must be performed at the following times.

- If ink or dirt is adhering to the deflection electrode, charge electrode, or detector electrode
- If a warning occurs
- If printing is erratic
- If characters fail to print
- If character height cannot be increased

**1** Make sure the gutter is fully closed.

**2** Place the head in the maintenance container so that ink does not spray the nearby environment. Remove the head cover by following the procedure described in "P161: Mounting and Removing the Head Cover".

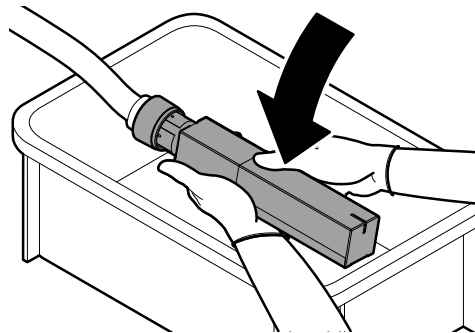

**3** Fix the electrode unit according to the procedure described in "P162: Fixing the Electrode Unit".

**4** Hold the print head so that the electrode unit lowers, and then clean off the dirt on the C. charge electrode and B. detector electrode using the special cleaning fluid.

- If the A. bias electrode is dirty
  - Wipe off carefully using a piece of wiper with cleaning fluid.
  - When it is terribly dirty, clean off the dirt using the cleaning fluid.
- If the B. detector electrode or C. charge electrode or are dirty
  - Clean the grooves between the electrodes using the cleaning fluid.

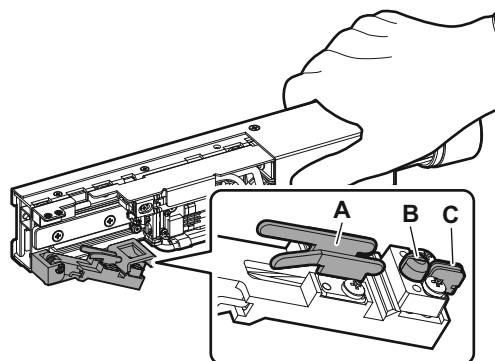

### CAUTION

- Make sure to lower the electrode unit before cleaning.

- 5** After cleaning, dry the electrode unit using either the enclosed blower or a dryer. In particular, dry thoroughly the gaps between the charge electrode.

#### Reference

- Ambient dirt can also be removed using dry compressed air for greater effectiveness.
- Precautions for using dryer;
  - The electric cables and electrode are vulnerable to high temperatures; therefore, keep the dryer at some distance when it is used for drying.
  - Please dry it enough with care not become high temperatures by repeating hot and cold air in turn together with 10 seconds.

#### CAUTION

- Cleaning fluid that adheres unvolatilized to the charge electrode or the detector electrode will be identified as a contaminant, and an alarm will be made.
- Insufficient drying may cause printed characters to become too small, or "electrification errors" may occur.

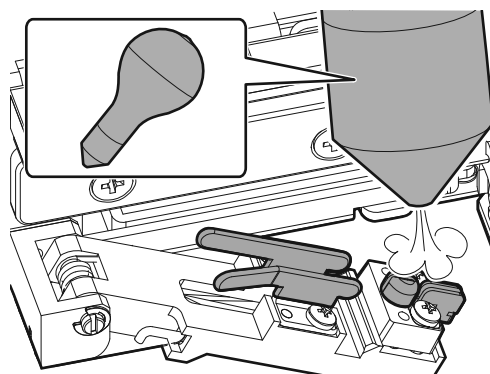

- 6** Return the electrode unit to its original position according to the procedure described in "P162: Fixing the Electrode Unit".

- 7** Mount the head cover by following the procedure described in "P161: Mounting and Removing the Head Cover".

### ■ Drying the Bias Electrode

When you pour cleaning fluid on the bias electrode while cleaning the electrode unit, or if the humidity inside the print head and bias electrode rises due to the climate and ambient environment, etc., and a nonconformance occurs such as being unable to increase the character size, it is necessary to dry the electrode unit using a dryer. Apply warm air evenly to the bias electrode board from nearby using a dryer.

#### **Danger**

- If the surface of the bias electrode is damaged, a short-circuit may occur, causing fire due to electrical discharge or electric shock. Take great care not to scratch the electrode surface during maintenance.
- Removing the head cover disables the application of high voltage. For safety's sake, however, take great care when working, even with the head cover removed.

## Cleaning the Gutter and the Ink Outlet

The work described here must be performed at the following times.





- If checking the gutter for stain
- If ink or dirt is adhering to the gutter
- If printing is missed on the low-bias side
- If printing on the low-bias side is uneven

### Reference

#### What is the low-bias side?

In continuous ink jet printers, the ink flow that flies continuously straight into the gutter writes characters by being biased (i.e., forced to curve) using an electric charge, but the dots that comprise the characters are called low-bias (near to the gutter) if the degree of bias is small, and high-bias (far from the gutter) when the bias is great.

Characters top and bottom, and low and high bias, depend on the print head settings and installation direction, and so do not necessarily agree. Open the print head and check to see whether either the top or bottom characters are high-bias or low-bias.

- 1** Remove the head cover by following the procedure described in "P161: Mounting and Removing the Head Cover".
- 2** Fix the electrode unit according to the procedure described in "P162: Fixing the Electrode Unit".
- 3** Turn ON the power supply. (Make sure the gutter is closed at this time.) During startup, the ink unit print lamp will flash.
- 4** When startup has been completed, the ink unit print lamp will stop flashing, and the screen will display the "Main Menu".
- 5** Refer to "P156: Screens Used in Maintenance Work" to display the unit test (outputs).
- 6** Use the cursor to select "Gutter open" using the   key, and turn ON the option using the   key. The gutter will open. Other parts are turn OFF.
- 7** After approximately 5 seconds have elapsed, turn OFF "Gutter open".

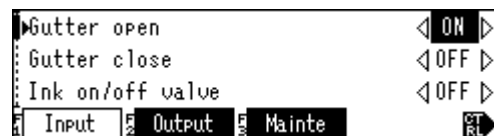

**8** Check the gutter for stain. If the gutter is clean, go to step **14** to close the gutter.

**9** If stained with ink, clean the gutter using cleaning solvent.

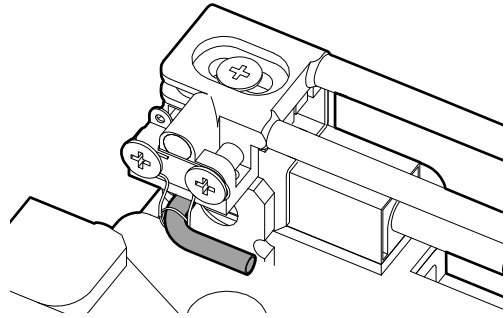

**10** Press the tip of washing bottle against the ink outlet, and blow cleaning solvent.

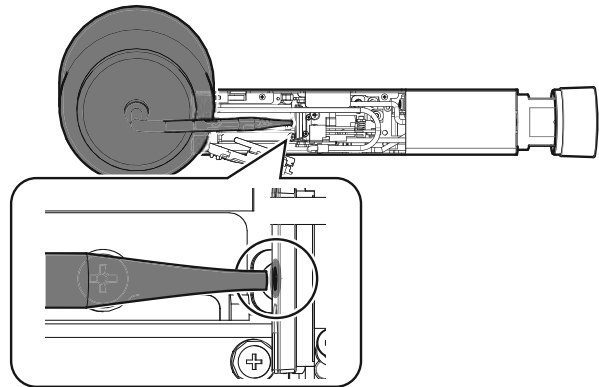

**11** Turn ON "Gutter close". The gutter will close. When the gutter has finished closing, the highlighted display will change automatically to normal.

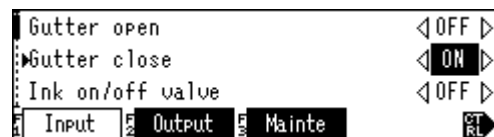

**12** Turn ON "Gutter open" to open the gutter again. After approximately 5 seconds have elapsed, turn OFF "Gutter open". If there is no stain of gutter, cleaning has complete

**13** If gutter is stained with ink, repeat step **9-12**.

- 
- 14** Turn ON "Gutter close" to close the gutter. When the gutter has finished closing, the highlighted display will change automatically to normal.

 **Caution**

- Make sure to close the gutter after cleaning has been completed. There is a risk of ink hardening in the nozzle.

- 15** Return the electrode unit to its original position according to the procedure described in "P162: Fixing the Electrode Unit".

- 16** Return the head cover to its original position by following the procedure described in "P161: Mounting and Removing the Head Cover".

- 17** Press the  key to return to the main menu.

**Reference**

Applying external vibrations to the print head may disrupt the ink flow to the gutter temporarily, causing lumps of ink to adhere to the gutter edge. Further, even without vibrations, the gutter may gradually become dirty with ink through prolonged use.

If the gutter is dirty with ink, ink droplets may be prevented from spraying normally during printing, causing poor print quality (in particular, missing dots on the low-bias side).

## Cleaning the Nozzle

The work described here must be performed at the following times.

- If the direction of ink spray is unstable
- If the nozzle is jammed and ink cannot exit
- If print quality is poor

### CAUTION

After cleaning the nozzle, make sure to adjust the direction of ink flow.

### ■ Removing the Nozzle

**1** Perform up to step **5** in the "P166: Cleaning the Gutter and the Ink Outlet" procedure.

**2** Turn ON "Gutter open". Other parts are turn OFF.

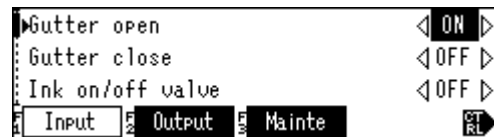

**3** Remove the fixing screws using a plastic screwdriver (No. 0), and then remove the nozzle plate.

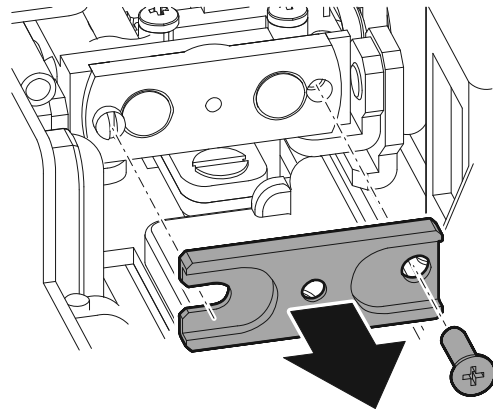

**4** Using a Philips screwdriver (No. 1), remove the two fixing screws, and then remove the nozzle. At this time, do not remove the O ring mounted to the gun.

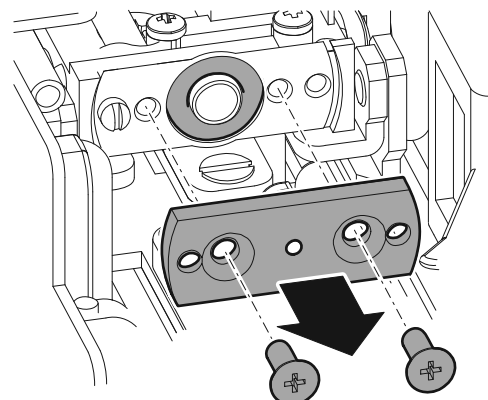

## ■ Cleaning the Nozzle

**1** Disassemble the nozzle.

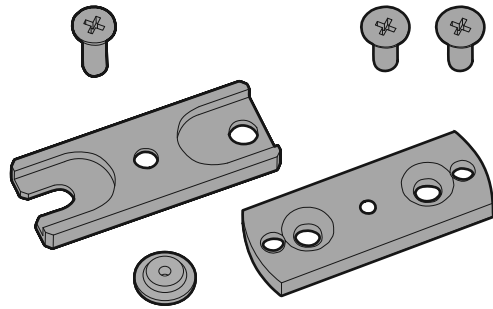

**2** After removing the nozzle, press out the tip of the cleaning bottle at the nozzle outside (where the ink exits) to create a forceful spray of cleaning fluid. If the dirt is particularly severe, dip the nozzle in the special cleaning fluid.

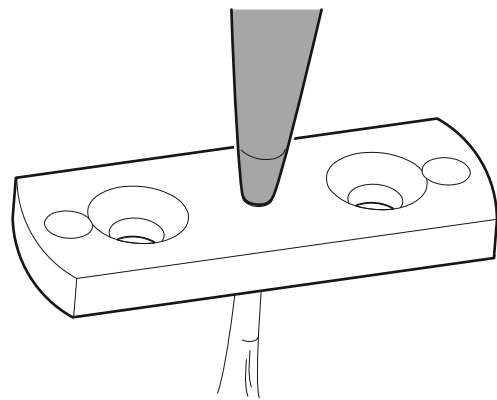

Alternatively, use an ultrasonic cleaner for approximately 20 minutes. (Otherwise, there is a risk of ink hardening in the nozzle pores.)

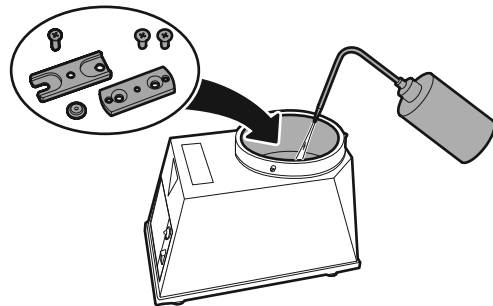

**3** Dry by blowing dry compressed air along the opposite direction from the ink flow (i.e., from the ink outlet to the inlet). If there is no compressed air, use the enclosed blower.

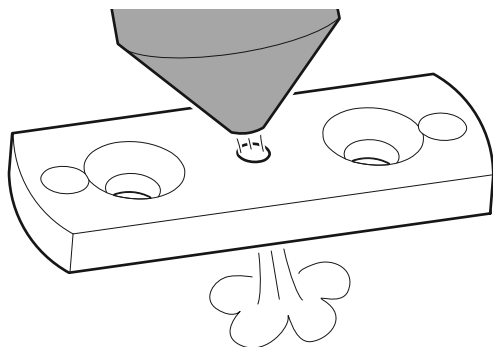

## ■ Mounting the Nozzle

- 1** Mount the nozzle and nozzle plate using the reverse procedure to "Removing the Nozzle".

### CAUTION

Attach the nozzle to see the serial number of the nozzle side.

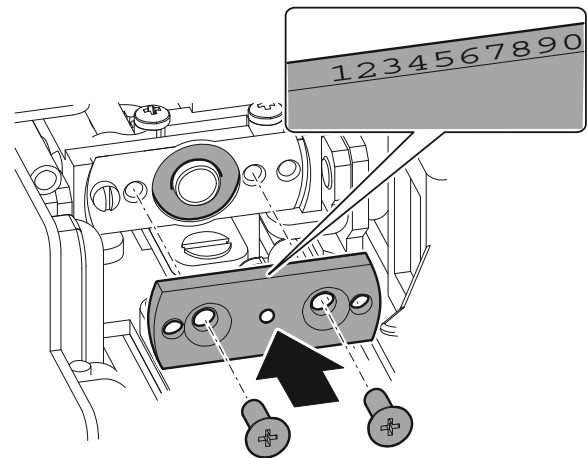

- 2** Once the nozzle has been mounted, turn ON the "Pump", "Ink on/off valve", and the "Bleed valve". Ink will be sprayed from the nozzle. Next, check that there is no ink leaking from the nozzle mountings. If ink is leaking from around the nozzle, turn OFF once again the "Pump", "Ink on/off valve", and the "Bleed valve", stop the ink spray, and remount the nozzle.

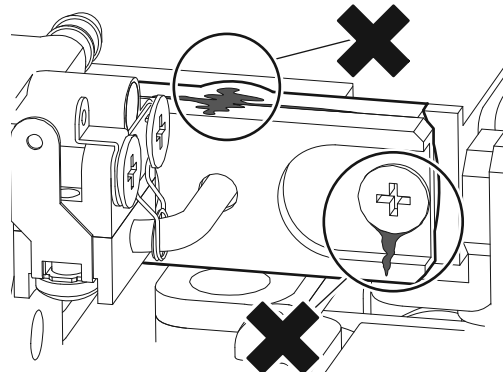

- 3** After cleaning and mounting the nozzle, make sure to check that the nozzle sealing is completely closed, and then adjust and check the direction of ink flow.

### Reference

The nozzle pores are extremely fine. Using the machine over long periods of time gradually causes a buildup of contaminants around the nozzle pores, which may prevent the normal creation of ink droplets and deterioration of print quality. Further, if ink should harden in the nozzle due to an operating error, or ink does not accurately strike the gutter due to a dirt jam, etc., the nozzle must be removed and cleaned.

## Adjusting the Ink Flow Direction

The work described here must be performed at the following times.

- If the ink flow misses the gutter
- If printing is missed on the low-bias side
- If ink dirt has built up in the gutter edge
- After removing or mounting the nozzle

### CAUTION

After cleaning the nozzle, make sure to adjust the direction of ink flow.

- 1** Place the head in the maintenance container so that ink does not spray the nearby environment.
- 2** Remove the head cover by following the procedure described in "P161: Mounting and Removing the Head Cover".
- 3** Fix the electrode unit according to the procedure described in "P162: Fixing the Electrode Unit".
- 4** Refer to "P156: Screens Used in Maintenance Work" to display the unit test (output).
- 5** Turn On the "Gutter open", "Ink on/off valve", and the "Pump". (Open the gutter so that ink can be sprayed.)

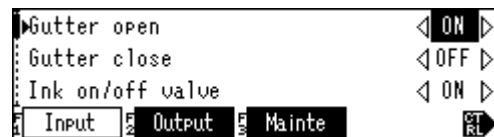

- 6** Slowly turn OFF the "Bleed valve" only by rotating several times. At this time, check whether the ink is sprayed straight from the nozzle, and that the ink spray is stable.

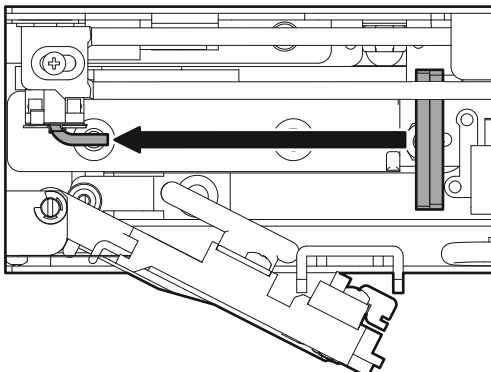

Condition seen from above

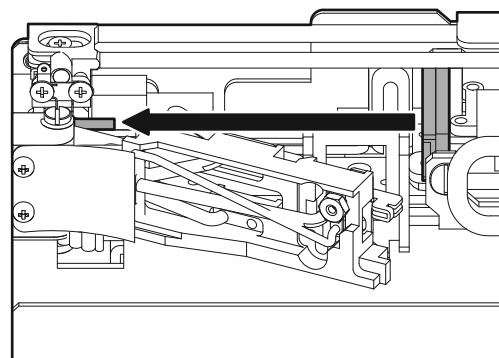

Condition seen from the side

**7** Turn OFF the “Bleed valve” and turn ON the “Circulation valve”.



**8** Check the direction of ink spray.

**A:** Check that entry to the gutter is a 7:3 position as seen from the side.

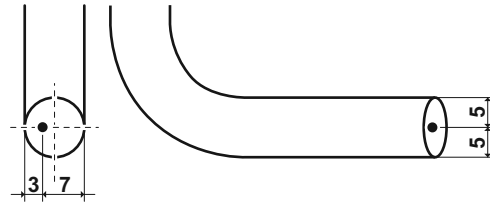

**B:** Check that the ink is entering the center of the gutter when seen from above.

**9** If the spray is misaligned, perform adjustments.

- Top to bottom misalignment

Loosen fixing screw A1 (using a 2 mm hexagonal wrench), and turn adjustment screw A2 (using a 2.5 mm hexagonal wrench) to adjust.

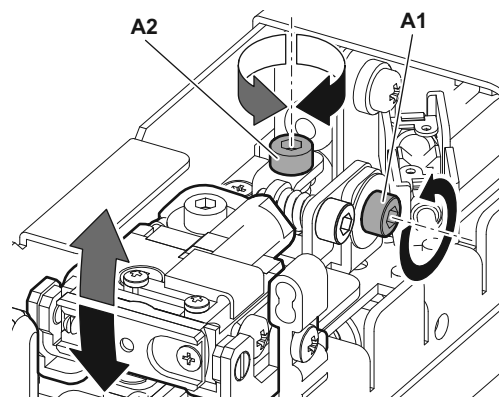

- Left to right misalignment

Loosen fixing screw B1 (using a 2 mm hexagonal wrench), and turn adjustment screw B2 (using a 2.5 mm hexagonal wrench) to adjust.

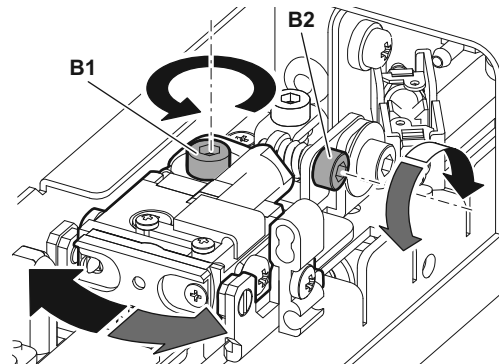

### Movement of ink flow after screw adjustment

#### ! Caution

Be careful, as loosening fixing screws A1 and B1 too much may change the ink flow direction when retightening after adjusting the ink flow.

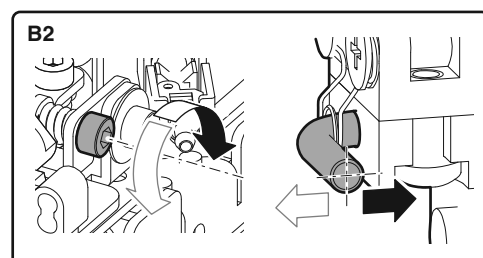
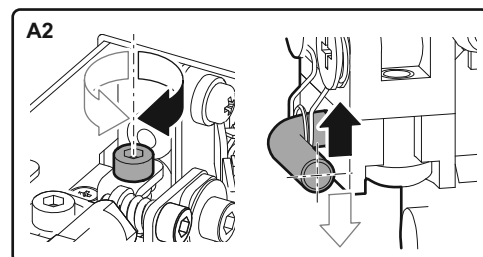

#### CAUTION

If there is a breeze in the work site, be careful as the the spray direction may be changed by the wind or the gutter dirtied between adjusting the ink flow direction and mounting the head cover.

**10** After adjustments have been completed, tighten fixing screws A1 and B1.

**11** Return the electrode unit to its original position according to the procedure described in "P162: Fixing the Electrode Unit". Further, at this time, try moving the electrode unit up and down several times, and check that the charge electrode is not dirty, and is not struck by the ink.

**12** Clean any ink dirt on the nozzle and gutter. After cleaning, turn ON "Gutter close".(Close the gutter so that ink can be sprayed.)Wait until the gutter has closed.



**13** When the gutter is fully closed, gently lower the electrode unit by hand.

**14** Mount the head cover by following the procedure described in "P161: Mounting and Removing the Head Cover".

**15** Press the  key to return to the main menu.

#### Reference

- Fine-tuning the ink flow direction can be performed in standard conditions (i.e., merely by removing the head cover while in print mode).
- After adjusting the ink flow direction, make sure to check that printing is performed correctly.

## Adjusting the Fully-closed Nozzle Sealing

The work described here must be performed at the following times.

- If ink is leaking from gaps in the nozzle
- If the ink flow direction is unstable
- After replacing the nozzle plate gasket
- After removing or mounting the nozzle
- If the cover does not fully close when checked

### ■ Checking Full Closure

- 1** Close the gutter and circulate the ink.
- 2** Place the head in the maintenance container so that ink does not spray the nearby environment. Remove the head cover by following the procedure described in "P161: Mounting and Removing the Head Cover".

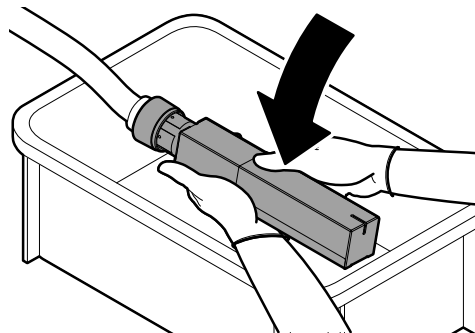

- 3** Use a cleaning bottle filled with cleaning fluid to drip a small amount of cleaning fluid onto the edges of the nozzle and gutter. (Tilt the nozzle upwards for easy access.)

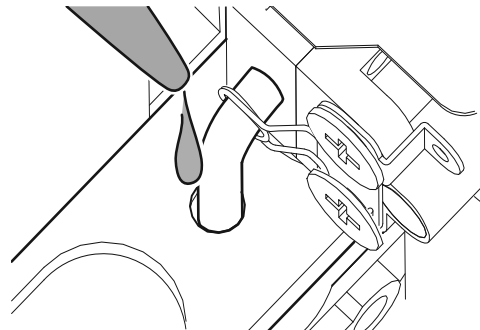

- 4** If the cover is not fully closed, there will be a faint sound, and the cleaning fluid will be sucked in. On the other hand, if the cleaning fluid remains on the nozzle without being sucked in, there is no problem.

If the cover is not completely close, make the following adjustments.

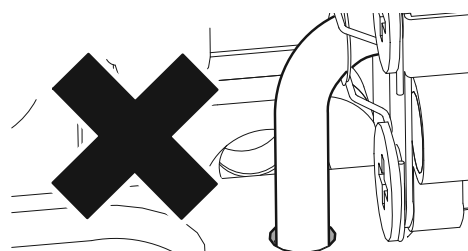
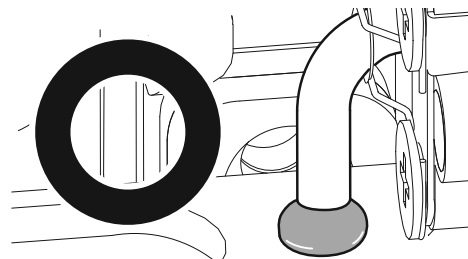

## ■ Adjusting the Closure

- 1** Fix the electrode unit according to the procedure described in "P162: Fixing the Electrode Unit".
- 2** Refer to steps **1** to **3** in "P169: Cleaning the Nozzle" to remove the nozzle plate.

### ! Caution

The screws used to fix the nozzle plate are extremely small. Be careful not to lose them.

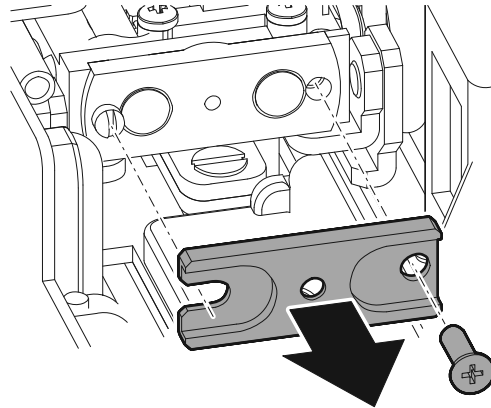

- 3** Turn ON "Gutter close" to close the gutter fully.

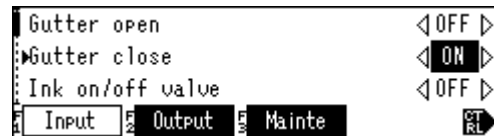

- 4** Wait until the the gutter has closed to the central head position.

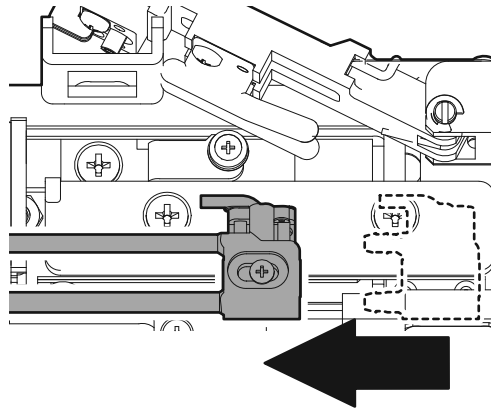

- 5** Turn OFF "Gutter close".

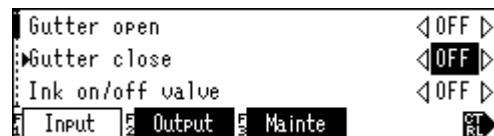

- 6** Clean the nozzle plate that has been removed from the gutter.

### Reference

At this time, point the head upwards so that the cleaning fluid can reach the electrical components behind the head. If cleaning fluid is spilled, angle the head straight down.

- 7** Pass the nozzle plate through the gutter.  
(Be careful of the angle.)

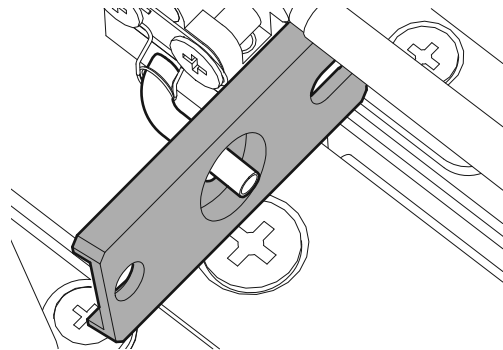

- 8** Pass the nozzle gasket through the tip of the gutter.  
(Pass right through to the back.)

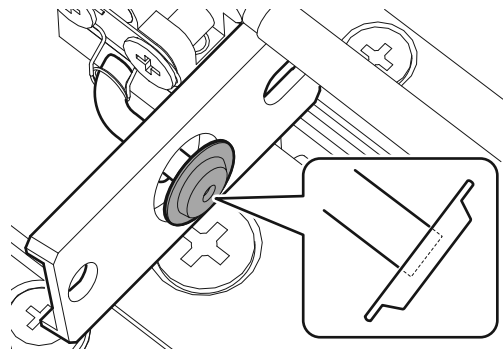

- 9** Thoroughly dry the cleaning fluid from the nozzle guard, nozzle gasket, and surrounding area using either the enclosed blower or dry compressed air. (If the cleaning fluid is not thoroughly dried, the gutter will not close completely.)

- 10** Turn ON “Gutter close”. Wait until the gutter is fully closed. At this time, be careful not to touch the nozzle plate or nozzle.

### Warning

While the gutter is operating, press down firmly with your hands to prevent the nozzle plate touching nearby parts. If the gutter moves while the nozzle plate is in contact with other parts, excess force may be applied to the gutter, causing the gutter to warp.

- 11** When the gutter has closed, press the  (Mainte) key to end maintenance mode.

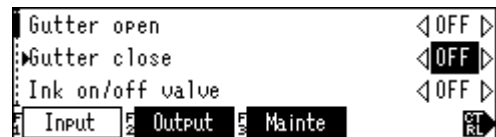

- 12** Fix the nozzle plate. (tilt the head upwards, mount the nozzle plate to the nozzle, and tighten the screws to fix the nozzle.)

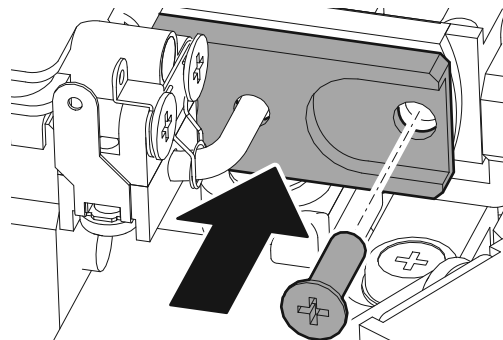

- 13** Check that the gutter is fully closed. If, as a result of the checks, the gutter cannot fully close, adjust the closure again.

#### Reference

After removing and remounting the nozzle, or if the nozzle plate gasket has deteriorated, the nozzle sealing cannot fully close. In this condition, ink will leak out from between the nozzle and the capped gutter while the device is stopped, and the nozzle and gutter surroundings will become dirty.

## Replacing the Nozzle Gasket in the Nozzle Palette

The work described here must be performed at the following times.

- If ink leaks from the gutter cap while the device is stopped
- The gutter cannot fully close no matter how many times it is adjusted

### Reference

If the nozzle sealing cannot fully close no matter how many times adjustments are made following the procedures described in "Adjusting the Nozzle Cap Closing", the nozzle gasket may be worn. At this time, replace with a new nozzle gasket. (Service life is approx, 1000 hours.)

- 1** Fix the electrode unit according to the procedure described in "P162: Fixing the Electrode Unit".
- 2** Refer to steps **1** to **3** in "P169: Cleaning the Nozzle" to remove the nozzle plate.
- 3** Replace the nozzle gasket with a new one.

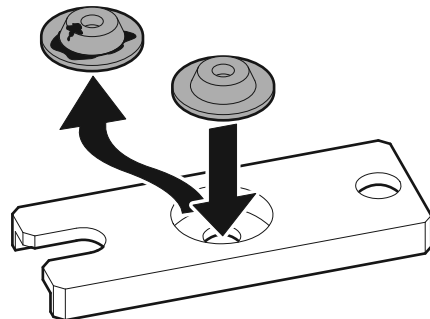

- 4** Remount the nozzle gasket and the nozzle plate.

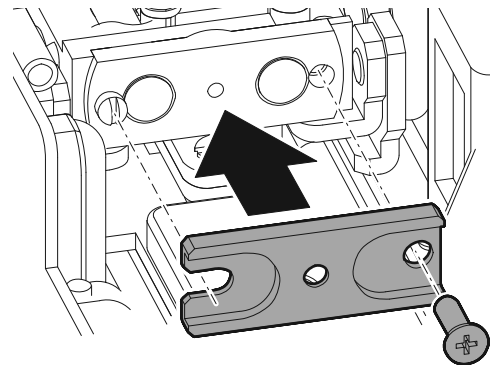

- 5** Turn ON "Gutter close" to close the gutter.

- 
- 6** After the gutter has closed, turn ON the “Ink on/off valve”, the “Circulation valve”, and the “Pump”.

The ink will start to spray.



- 7** Loosen the nozzle plate again, and adjust the closure. If, as a result of the checks, the gutter cannot fully close, adjust the closure again.

- 8** Remove the sticker already mounted to the back of the ink head, and mount to the same position the replacement parts control sticker enclosed with the replacement nozzle gasket.

- 9** Enter on the mounted replacement parts control sticker the date of replacement and the time until next replacement, and remove the back of the transparent seal and mount. (The time until next replacement is the value obtained by adding 1000 hours, which is the nozzle gasket replacement period, to the value to the time that the power supply is turned ON according to the unit history.)

## Cleaning the Gutter Slide Unit

The work described here must be performed at the following times.

- If the gutter does not move at all
- If there is an abnormal noise or movement is not smooth when the gutter is opening or closing
- If there is ink or dust adhering to the spindle or guide

- 1** Pour cleaning fluid onto A. Spindle and B. Guide to wash away any dirt or dust.

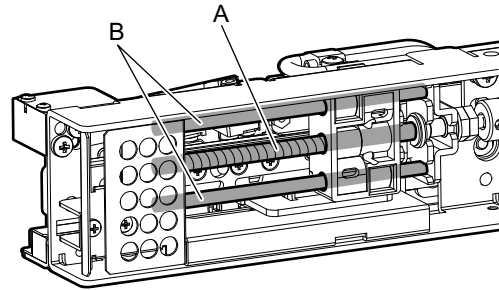

## Checking and Adjusting the Clearance between the Gutter and Nozzle

The work described here must be performed at the following times.

- After the ink flow direction has been adjusted
- While adjusting the nozzle sealing closure

- 1** When checking the clearance, make sure to open the ink unit test by referring to steps **1** to **5** in "P166: Cleaning the Gutter and the Ink Outlet", and stop the ink flow and remove the nozzle plate.

- 2** After adjusting the ink flow direction, there is a risk of clearance eccentricity. If the gutter and nozzle come into contact while the gutter is in this condition, there is a risk that the gutter will become warped. Consequently, after adjusting the ink flow direction, slightly loosen the clearance adjustment screws with the gutter fully open, and move the gutter away from the nozzle by at least 1mm.

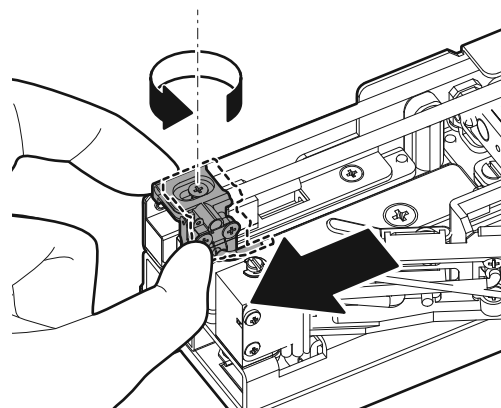

- 3** Fully close the gutter.

- 4** Insert a 0-2mm gap gauge into the space between the gutter and nozzle, and move until the gutter lightly touches the space gauge, and then tighten the gutter clearance adjustment screws.

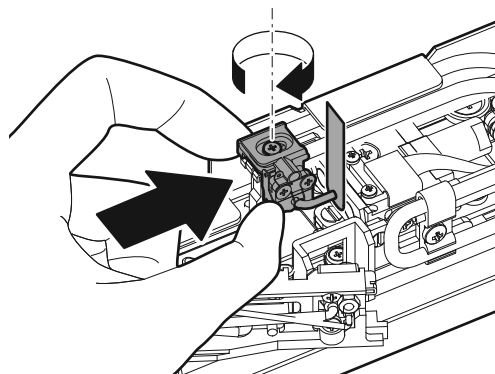

- 5** Finally, check that the 0.3mm space gauge cannot be inserted into the gap.

#### Reference

For accurate nozzle sealing, the clearance between the nozzle surface and the gutter pipe must be adjusted to between 0.2 and 0.3mm. After adjusting the ink flow direction or while adjusting the nozzle sealing closure, check the clearance, and if the clearance is incorrect, perform adjustments.

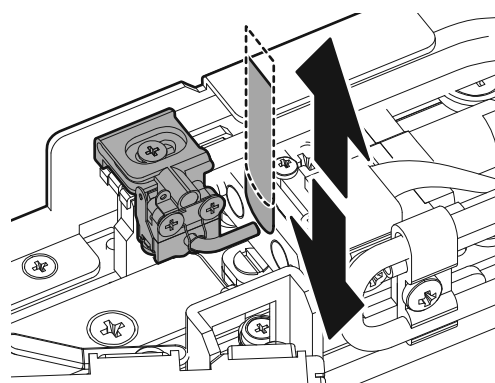

## Replacing the Head Filter

The work described here must be performed at the following times.

- If the direction of ink spray has changed
- If the character height is too small

#### CAUTION

Be careful that no dust or other contaminants enter while performing this work.

- 1** Stop the head. (If the head is stopped, proceed to step **2**.)
- 2** P156: Start maintenance with reference to the "Screens Used for Maintenance Work".
- 3** Turn OFF all outputs.



- 4** Open the head filter cap. (At this time, there is a risk that ink will flow out of the head filter body, so protect the surroundings.)

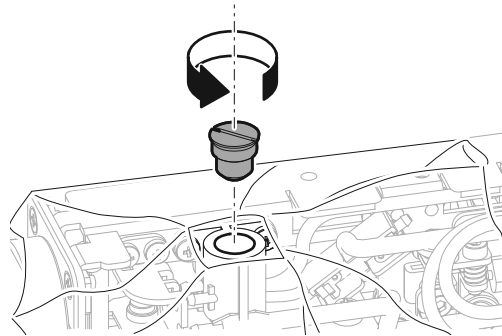

- 5** Remove A. O ring, B. Head filter ring, and C. Filter using tweezers.

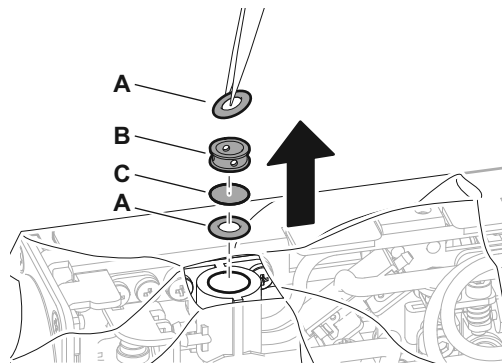

- 6** The head filter cap and head filter ring will be reused, so wash them thoroughly.



- 7** Clean inside the head filter body using cleaning fluid. Washing inside the pipes from the head filter body to the gun (where the nozzle is mounted) is effective.

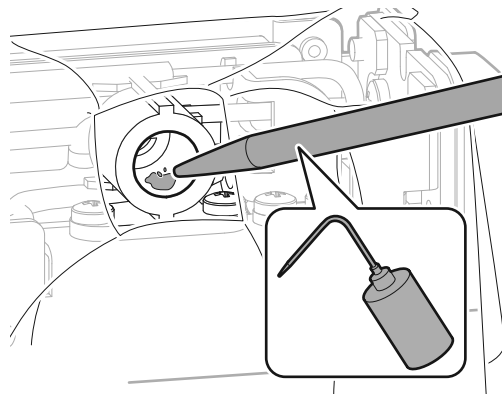

- 8** Mount a new filter and parts. (Be careful of the filter angle.) Place the following parts in the head filter body, and fix the cap. Mount the parts in the following order: A. O ring, B. Filter, C. Head filter ring, D. O ring, and E. Head filter cap.

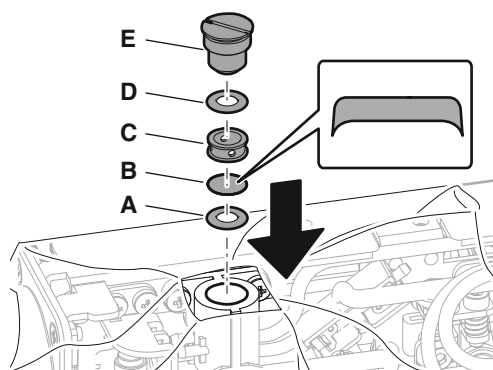

- 9** Turn ON the "Pump" and "Ink on/off valve", and discard the first 3 to 5s of ink. Next, turn OFF the "Pump" and "Ink on/off valve" again. If ink does not exit the nozzle at this time, P169: clean the nozzle.

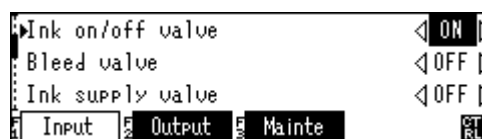

**CAUTION**

If the filter is jammed inside the head, the ink spray direction may change, and character height may be reduced. If this occurs, the filter must be replaced.

### Bleed Processing

Bleed processing is a process to return the spray direction to normal if the ink spray direction has been changed.

#### CAUTION

If the gutter pipe has been adjusted by bending, there is a possibility that the bias electrode, etc., has been damaged, which may cause fire or other problems, so make sure never to bend the gutter pipe.

The work described here must be performed at the following times.

- If the direction of ink spray has changed
- The head filter has been replaced

- 1** Stop the head. (If the head is already stopped, proceed to step **2**.)
- 2** Refer to the "P156: Screens Used in Maintenance Work" and display the maintenance screen.
- 3** Press **Ctrl** key, and **F1** (Bleed) key to start the bleed processing.
- 4** Perform bleed processing for approx. 5 mins.
- 5** Press **F1** (Bleed) key again to stop the process.
- 6** Press **Esc** key to return to the main screen.

#### Reference

If the ink flow direction has changed, clean the head after performing this process. Further, some air may be mixed in the ink pipes after the filter has been replaced. If any air remains in the pipes, it will jam the nozzle holes and may change the ink spray direction. Consequently, perform air expulsion to remove air trapped in the pipes.

# Main Unit Maintenance

## Replenishing Ink and Solvents

The work described here must be performed at the following times.

### ■ If a replenish warning occurs

- 1** Unlock and open the front panel of the CCS-R main unit.

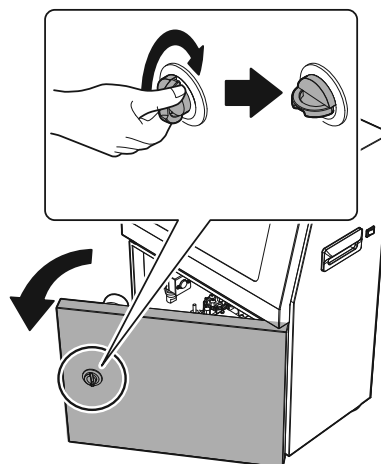

- 2** Check that there is a suitable amount of ink and solvent in A. Ink tank and B. Solvent tank.

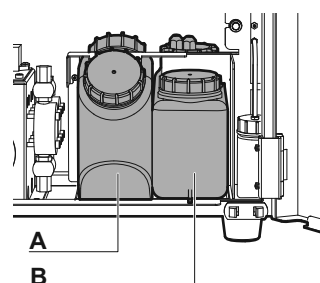
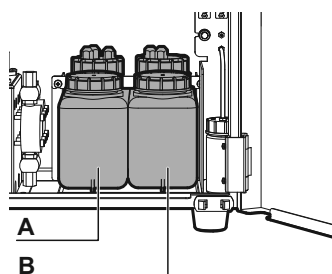

- 3** If the remainder is low, remove the tank caps, and replenish the ink and solvent.

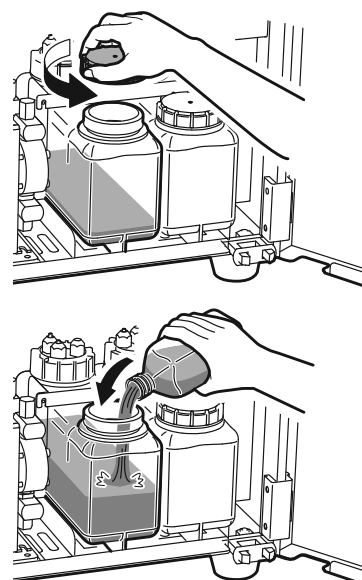

Before inserting ink into the pigment ink machine, shake the bottle well until there is no sediment on the bottom.

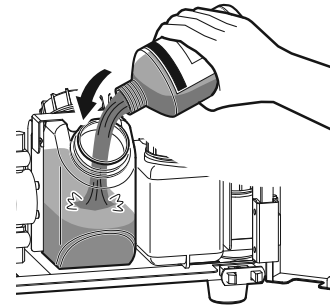
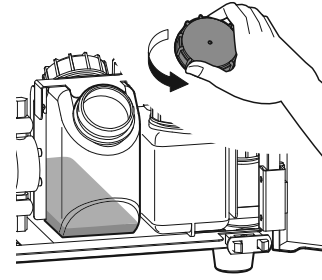

To check for sediment, hold the bottle inverted for 30 seconds, and look at the bottom of the bottle. If sediment remains after shaking the bottle, mix well with a stirrer inside the bottle.



**4** After filling the ink tank, close the cap securely.

### Caution

- If the wrong ink or solvent is inserted by mistake, a malfunction may occur immediately, so be very careful.
- During replenishment, make sure that the tanks are not filled beyond their full level shown.
- Check that the caps are securely closed.



## ■ If a replenish alarming occurs

(Ink)

**1** Fill the ink tank with ink.

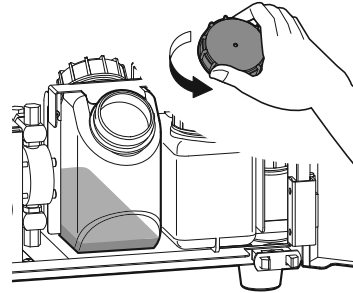

**2** Press **F1** (Refill) key to restore the ink status. (If the ink is filled to a set level, the function will end automatically.)

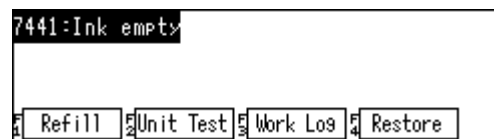

(Solvent)

**3** Fill the solvent tank with solvent.

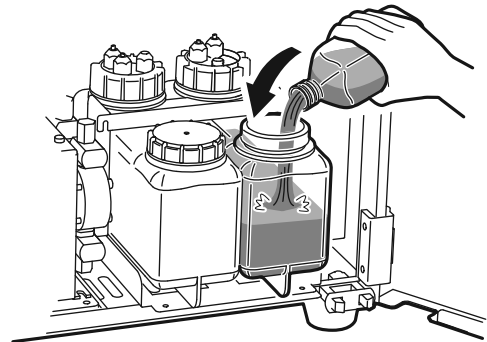

**4** Press **F4** (Go on) key.

## Disposal the Waste Liquid

Works described here are daily check. Check the condensate tank and observe the following points before waste liquid of condensate tank overflows.

**1** Open the lower panel of the CCS-R main unit and check the liquid level in the condensate tank.

**2** If the level is too high, discard the waste liquid.

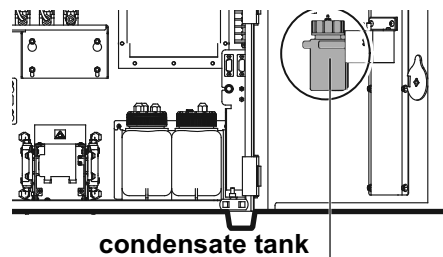

## Adjusting Ink Pressure

The work described here must be performed at the following times.

- If printing is erratic
- If there is an abnormal sound from the pump

**1** Check the current pressure. Turn ON the power supply, and press **Ctrl** key on the main menu. And press **F1** (Unit Info) key to display the unit information. Check the ink pressure display on the bottom left.

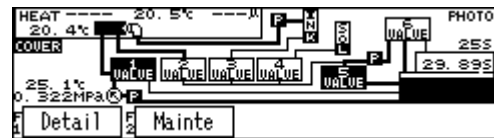

**2** If the pressure value is different from the correct value, adjust the pressure. Open the panel on the CCS-R main unit. Turn the pressure adjustment screw clockwise to increase the pressure, and counter-clockwise to reduce the pressure. Use a large slotted screwdriver to turn the screw.

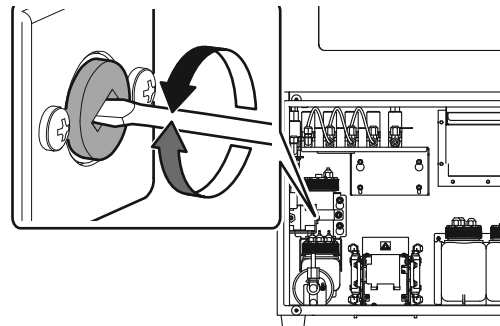

### Caution

For the ink pressure set value, refer to "Ink compatibility table".

## Adjusting Pump Pressure

The work described here must be performed at the following times.

- If replace the ink pump (PD1141A2401, PD1141A2501, PD1141A2502, PD1141A2601, YH1175C01, YH1176C01, and YH1176C02)
- If replace the diaphragm set(CCS3000-MP-DPSET2) of the ink pump.

- 1 Press **Ctrl** key on the main menu. And press **F1** (Unit Info) key to display the unit information.



- 2 Unlock and open the front panel. Remove the fixing screw on the ink pump using a phillips screwdriver (No.2). Remove the ink pump from the main unit.

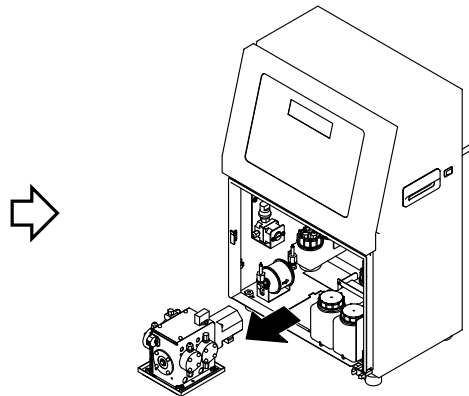
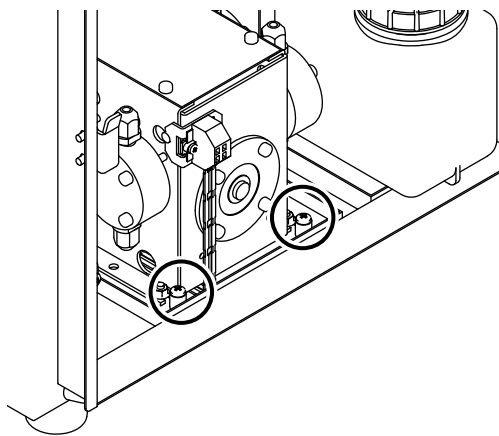

- 3 Press **F2** (Mainte) key to switch to maintenance mode. The ink circulation stops.



- 4 Turn the pressure adjusting screw of the regulator clockwise to tighten completely, using a wide slotted screwdriver.

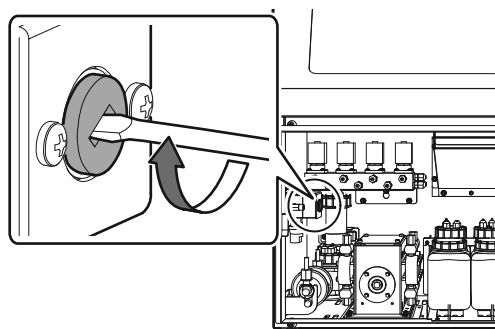

- 5 Press **F2** (Mainte) key to switch to standard mode.

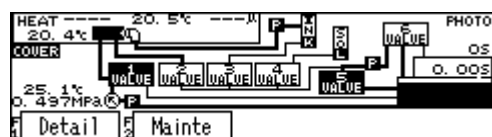

- 6** Turn the two pressure adjusting screw of the ink pump using a phillips screwdriver (No.2) to adjust the pump pressure to  $0.500 \pm 0.005\text{MPa}$ . Turning the pressure adjusting screw counterclockwise increases the pressure, whereas turning it clockwise decreases the pressure.

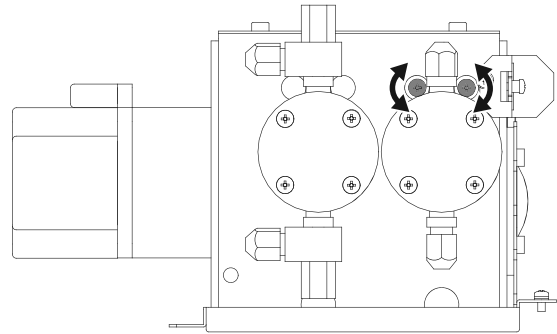

### ! Caution

Be sure to turn evenly the two pressure adjustment screws of the pump.  
e.g. if turning the left-side screw counterclockwise one-turn, turn the right-side screw counterclockwise one-tuen.

- 7** After adjusting ink pump pressure, press **F2** (Mainte) key, to switch to maintenance mode. Press **F3** (Bleed) key, to perform the air bleed process.



- 8** After the air bleed process for approximately 10 seconds, press **F2** (Mainte) key, to switch to standard mode. Check the ink pump pressure is in the range of  $0.500 \pm 0.005\text{MPa}$ . If the ink pump pressure exceeds the range of  $0.500 \pm 0.005\text{MPa}$ , repeat step **6** ~ **8**.



- 9** Refer to “P189: Adjusting Ink Pressure”, adjust to the recommended pressure.

- 10** Reinstall the ink pump in place, and secure it with the fixing screw.

### Reference

Putting the cables inside the main unit before reinstalling the ink pump makes the work easier.

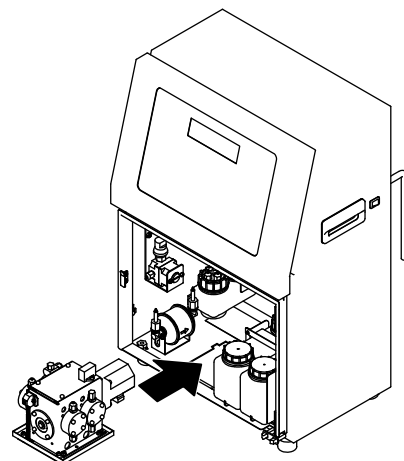

## Replacing the Ink Filter

The work described here must be performed at the following times.

- If the pressure will not rise to a suitable value even after adjustment
- If there is an abnormal sound from the pump

**1** Display the unit output test using the "P166: Cleaning the Gutter and the Ink Outlet" procedure.

**2** Unlock and open the front panel.

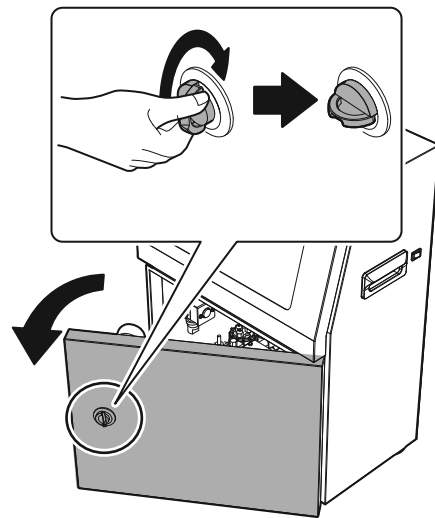

**3** Remove the ink filter on the front left.

Standard unit

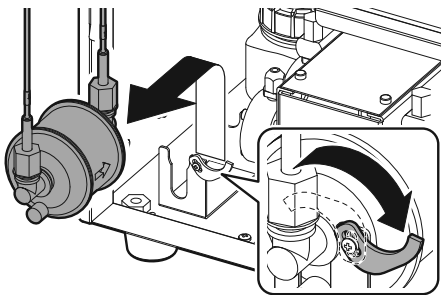

Pigment ink unit

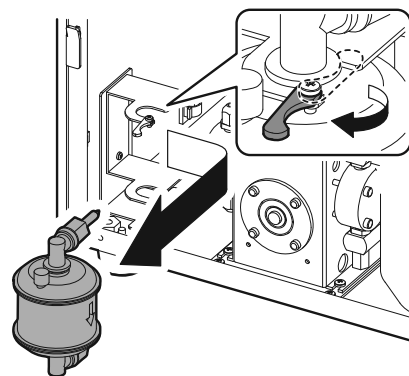

**4** Remove the (white) joint on the ink filter. Rotate counter-clockwise to remove. Manual removal is also possible, but if it cannot be removed by hand, use a 17-mm spanner or monkey wrench.

### Caution

Place it in the maintenance container while replacement, because ink may drip out.

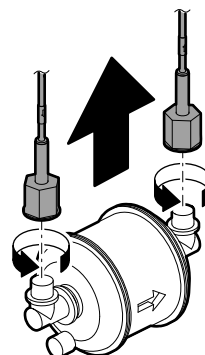

- 5** Mount the new ink filter.

**CAUTION**

The ink filter is designed to mount in the specific direction.  
Be careful not to confuse the IN and OUT sides.

- 6** Press **Ctrl** key, and turn ON **F1** (Bleed) key. And then shake the ink filter gently by hand during two minutes.

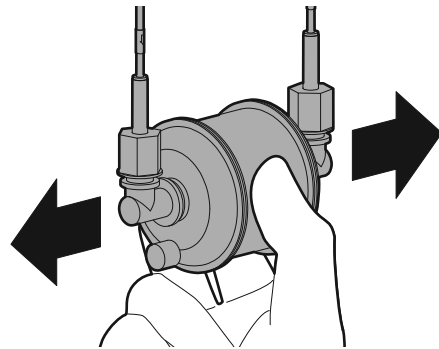

- 7** Mount the filter to its original site, and close the test screen.

Standard unit

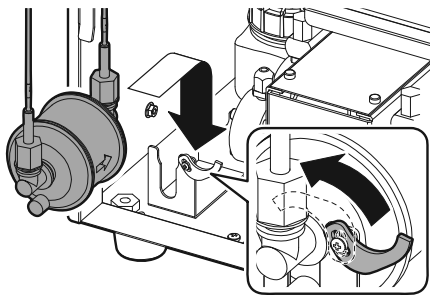

Pigment ink unit

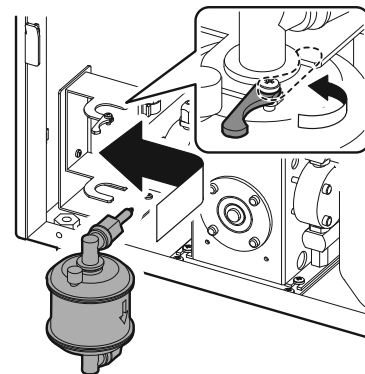

- 8** Enter the date of replacement and time of next replacement on the replacement parts control sticker, and remove the transparent sticker back and mount the transparent sticker.  
(The next replacement time is the value obtained by adding the 1500 hours replacement period for the filter to the amount of time that the main unit power supply has been turned ON according to the unit log.)

- 9** Mount a replacement parts control sticker to the replaced ink filter to finish.

## Replacing the Large Circulation Filter

### Reference

- In only limited types of ink, large circulation filter is equipped. For details, refer to "Ink compatibility table".

The work described here must be performed at the following times.

- If quantity of ink is enough, but "Ink out" error occurs frequently
- If there is an abnormal sound from the pump

**1** Display the unit output test using the "P166: Cleaning the Gutter and the Ink Outlet" procedure.

**2** Unlock and open the front panel.

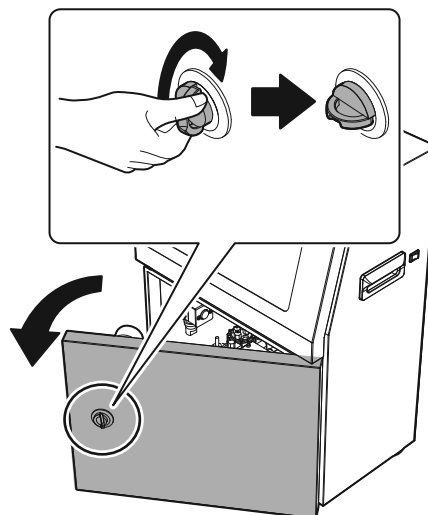

**3** The large circulation filter is located on the front depths.

Release the lock that secures the large circulation filter and remove the large circulation filter.

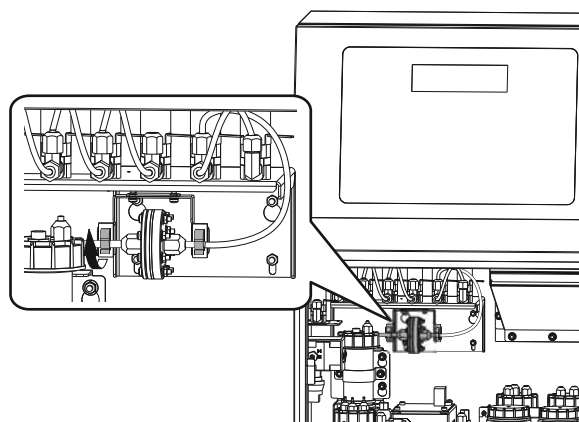

- Remove the (white) joint on the large circulation filter. Rotate counter-clockwise to remove. Manual removal is also possible, but if it cannot be removed by hand, use a 12-mm spanner or monkey wrench

### Caution

Place it in the maintenance container while replacement, because ink may drip out.

- Mount the new large circulation filter.

### CAUTION

The large circulation filter is designed to mount in the specific direction.  
Mount it with the side of the groove on the filter mated with the IN side of the tube.

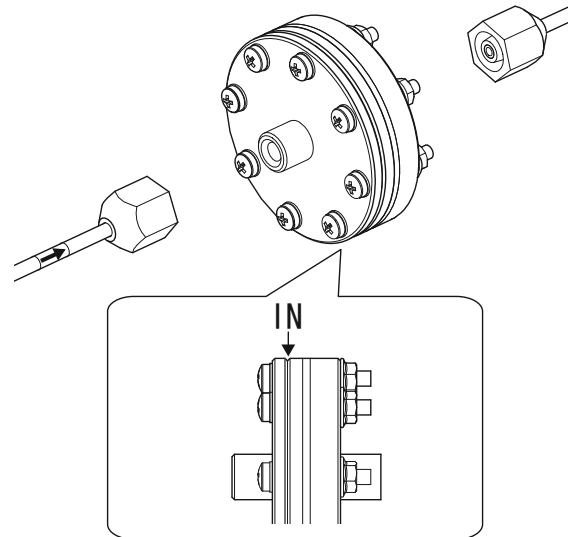
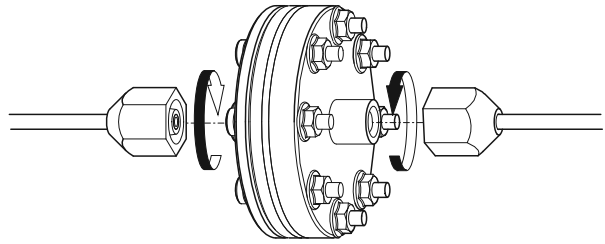

- Reinstall the large circulation filter in place, and secure with the fixing hook. So finish the unit test screen.

- Enter the date of replacement and time of next replacement on the replacement parts control sticker, and remove the transparent sticker back and mount the transparent sticker.  
(The next replacement time is the value obtained by adding the 1500 hours replacement period for the filter to the amount of time that the main unit power supply has been turned ON according to the unit log.)

- Mount a replacement parts control sticker to the replaced large circulation filter to finish.

---

## Cleaning and Replacing the Extractor Air Filter

The work described here must be performed at the following times.

- During monthly inspections
- If the fan is creating an abnormal noise

**1** Unlock and open the front panel.

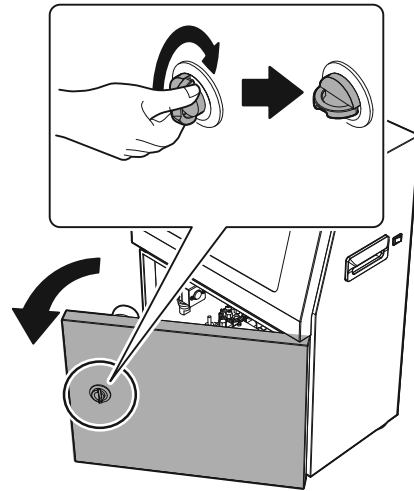

**2** Remove the filter tray in the top right.

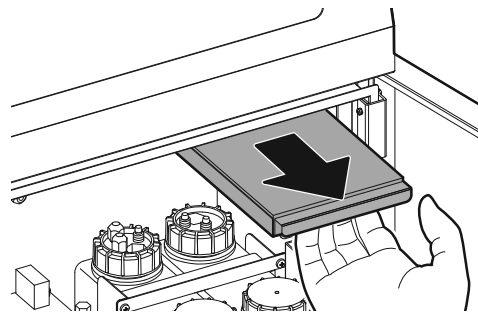

**3** Remove and clean the air filter.  
If the dirt is particularly severe, replace the filter.

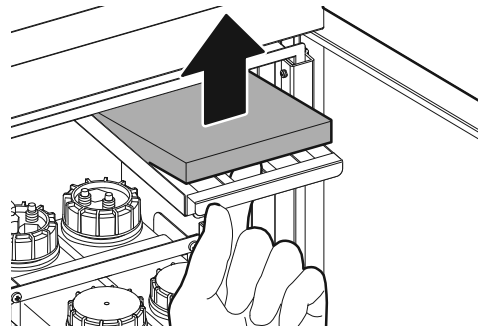

### 4 Mount the air filter.

#### CAUTION

The filter mounting direction is fixed. Make sure that the surface to which the PP sheet is mounted is facing upwards, and mount by bringing forwards the part to which the PP sheet is not mounted.

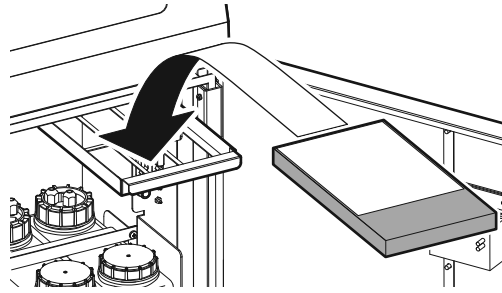

### 5 Close the filter tray, and close the front panel.

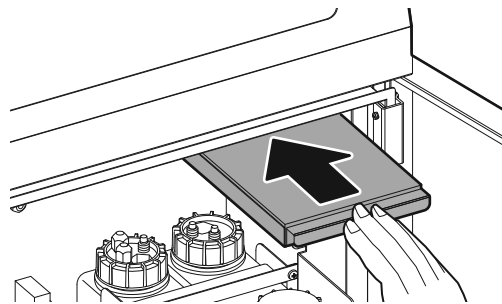

---

## Replacing the Air Pump

- 1** Unlock and open the front panel.
- 2** Remove the connector and the tube.

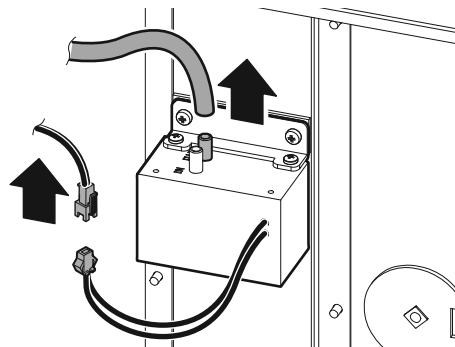

- 3** Remove the two screws, and then remove both the stopper and the air pump.

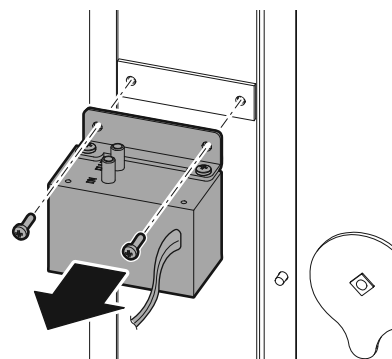

- 4** Remove the stopper, and mount a new air pump.

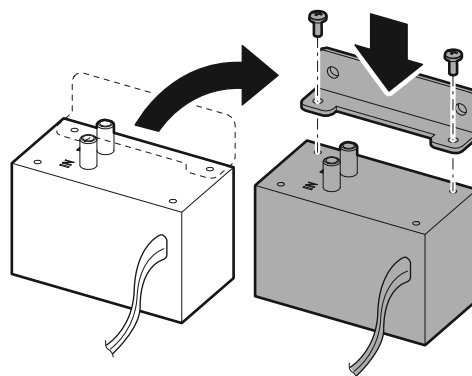

- 5** Mount a new pump to the panel.

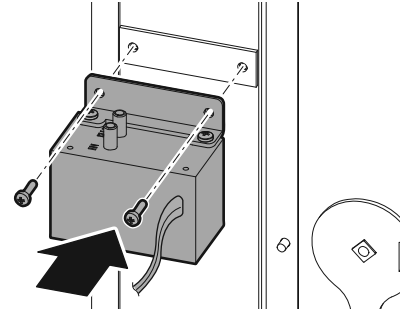

- 6** Connect the connector and tube.

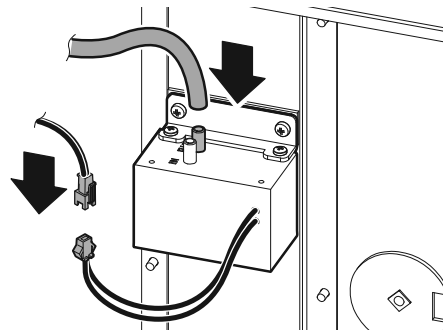

# Replacing the Backup Battery

**1** Turning OFF the power supply and breaker.

**CAUTION**

When replacing the backup battery, please work after having executed the “save backup”.

**2** Remove the fixing screws using a screwdriver.

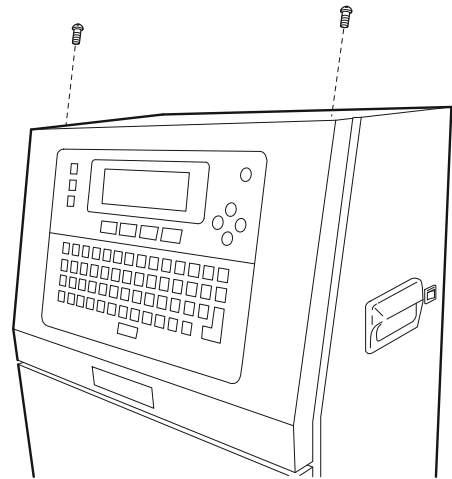

**3** Open the control panel cover.

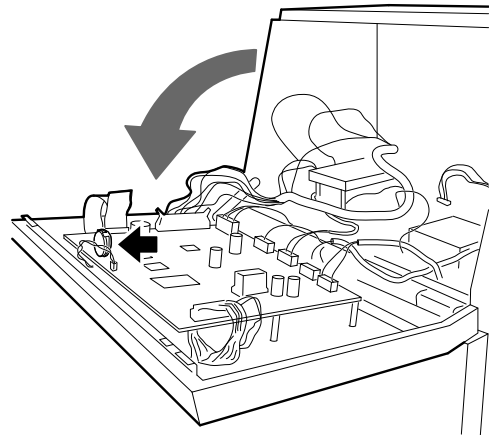

**4** Remove the battery, and mount the new battery. About the direction of mounting battery, surfaced side is positive.

**Reference**

- The battery type is lithium coin battery CR2032.
- Dispose of batteries according to the instructions specified by your local community waste collection / recycling center.

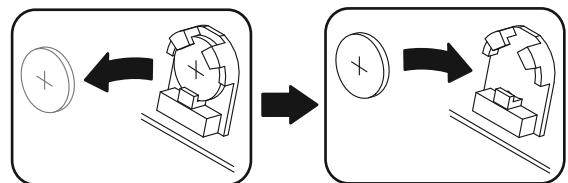

**5** Close the control panel cover, and remount the fixing screws.

## Replacing the diaphragm unit

### Reference

The work procedure may vary depending upon the type of Ink pump used. "DPF204RA1" is the kind of ink pump, which performs this work procedure.

In case of Ink pumps other than the above mentioned type, Please refer "Replacing the diaphragm set manuals".

The Work procedure described in this section will be necessary in the following cases.

- When the Warning alarm code for "Ink Leak" is displayed in the operation panel.

- 1** Turning OFF the power supply and breaker.
- 2** Unlock and open the front panel

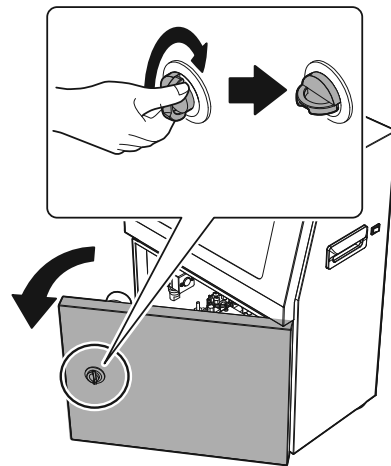

- 3** Remove the two screws that hold the tray of ink pump, and then put out the ink pump to the outside of the main unit.

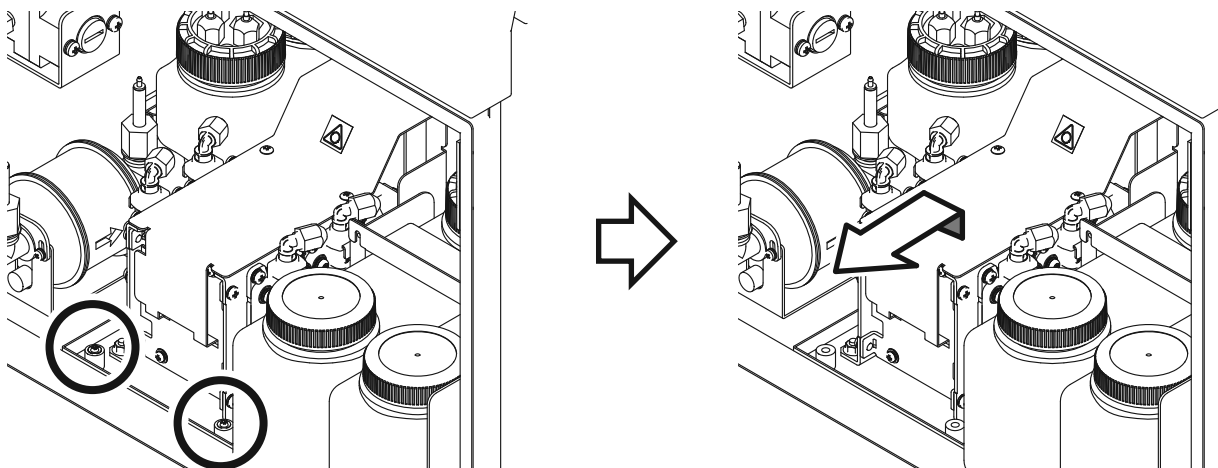

- 4** the circulation diaphragm unit is located the right front side of the pump below the ink pump.

- 5** Remove the two screws of the circulation diaphragm unit by using a phillips screwdriver(No.2).

- 6** Pull up the diaphragm unit by tilting it the top and remove the diaphragm unit from the bottom of the catch.

#### Reference

Since the diaphragm unit has tubes connected in it, there is a risk of making damage to the tube when pulled forcibly.

Please do draw an amount corresponding to the margin of the tube.

- 7** Unplug the ink leakage detection FPC mounted below the diaphragm unit from the detection board of the main unit.

- 8** When reconnecting the fitting, the ink from the joint and diaphragm unit may leak out, please protect the surrounding of the diaphragm unit with using a waste cloth. Also please do make sure that the ink does not enter/affect into the side detection board.

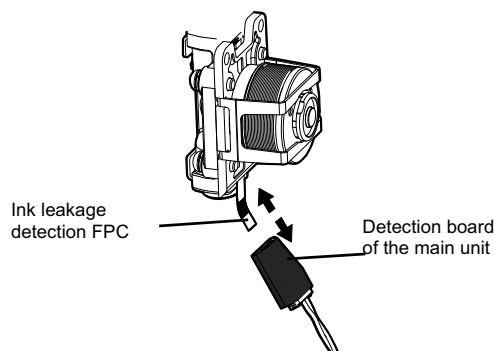
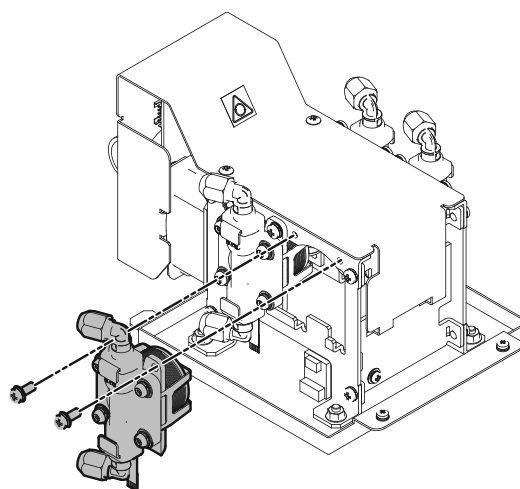
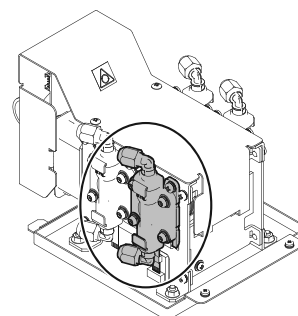

- 9** Pull the clasp of the diaphragm unit using a flathead screwdriver and remove the top of the joint. Insert the new diaphragm in the place of removed unit, please make sure of fixing with fasteners.

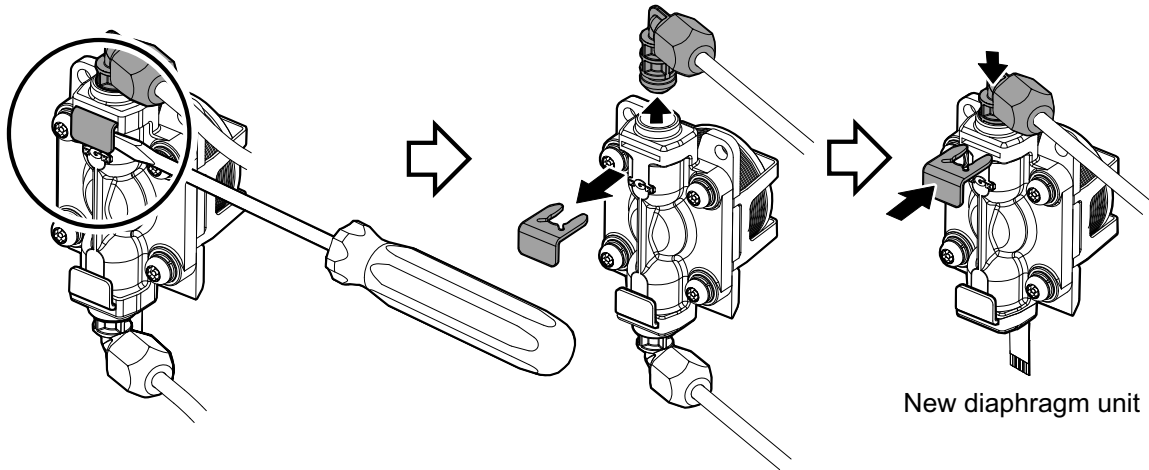

- 10** The lower side of the joint is removed in the same manner, and attach the new diaphragm unit in it.

### Reference

- Make sure not to misplace the top and bottom of the diaphragm unit.
- When the fasteners and fittings are not proper in the diaphragm, it may cause ink leakage. So, do the fittings and fasteners properly without any loose fittings.
- While doing the fittings, please be careful to avoid ink leakage on the ink leakage detection FPC of the diaphragm unit.

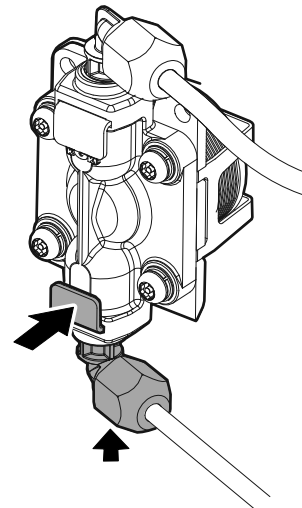

- 11** Pull the ink leakage detection FPC mounted below the diaphragm unit to the detection board of the man unit.

### Reference

- Please be careful to avoid getting ink dirt on the connection portion of the ink leakage detection FPC and the cables in the sides ink leakage detection board.

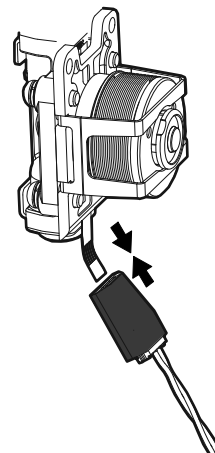

- 12** Place the diaphragm unit to the pump body, and fix it with the two mounting screws.

**Reference**

- Make sure that the spring of diaphragm unit is mounted with care so as not to damage the surroundings.

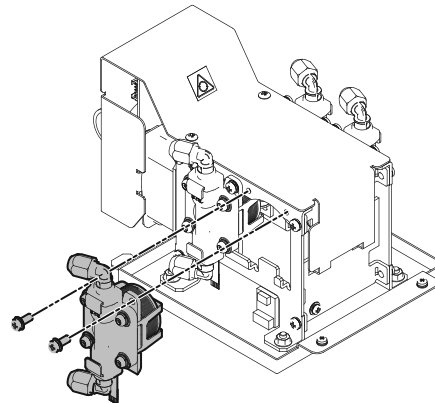

- 13** Put the ink pump into the main, and then fix it with the screw.

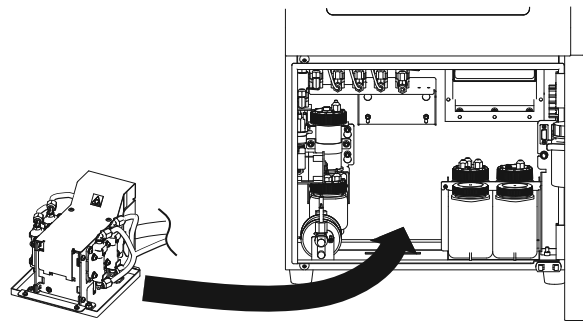

- 14** Turn on the main switch on the right side of the main unit. Turn on the power switch on the operation panel, and then boot the system of the CCS-R.

- 15** Mount a replacement parts control sticker to the replaced ink pump to finish.

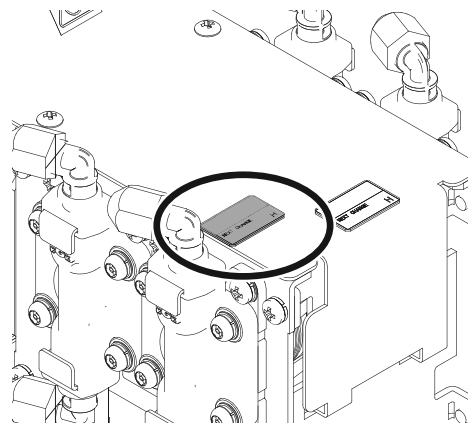

## Long-term Storage of Pigment Ink Machine

The operations described here must be performed if the machine will be idle for one month or more.

**1** Drain all ink from the tank.  
For drainage method, refer to "P143: Draining Process".

**2** Pour solvent in the ink tank.

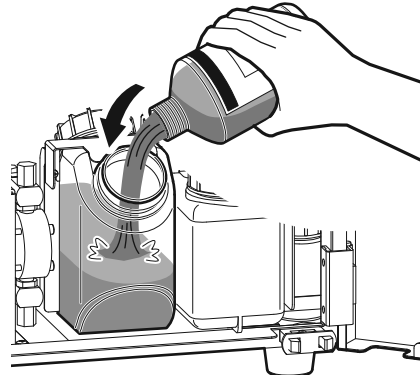

**3** Perform the air bleeding process.  
For information on the air bleeding process, refer to "P141: Bleed Process".

---

## Pigment Ink Machine Restart after Long-term Storage

The operations described here ensure that the pigment ink machine is able to print again after long-term storage.

**1** Drain all solvent from the tank. For information on the drainage handling, refer to "P143: Draining Process".

**2** Pour ink into the ink tank.

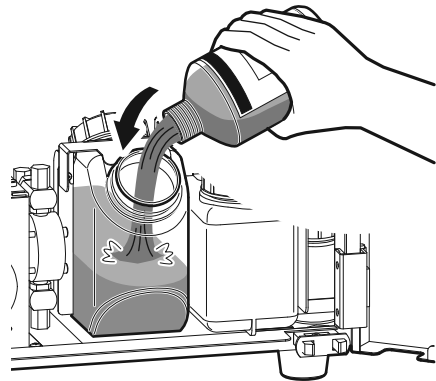

**3** Perform the air bleeding process. For information on the air bleeding process, refer to "P141: Bleed Process".

**4** Drain the ink again in the same way as step **1**.

**5** When drainage is complete, pour in new ink, and perform the air bleeding process again.

**6** Before use, leave idle for a short time until viscosity is stable.

## Dispose this Product

This product equipped lithium coin battery CR2032.

In the EU there are separate collection systems for used batteries and accumulators.

When dispose this product, remove the battery.

Please, disposal of batteries and accumulators correctly at your local community waste collection / recycling center.

### ■ Symbol mark

This symbol mark is for EU countries only.

This symbol mark is according to the directive 2006/66/EC Article 20.

This symbol mark means that batteries and accumulators, at their end-of-life, should be disposed of separately from your household waste.



### ■ How to remove the battery

**1** Remove the fixing screws using a screwdriver, and then open the control panel cover.

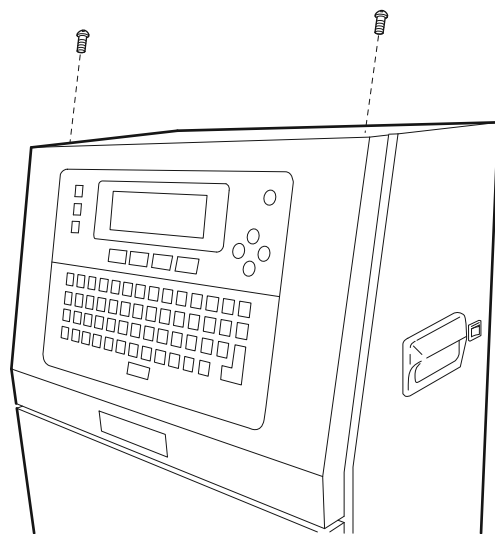

**2** There is the lithium coin battery shown in the illustration.

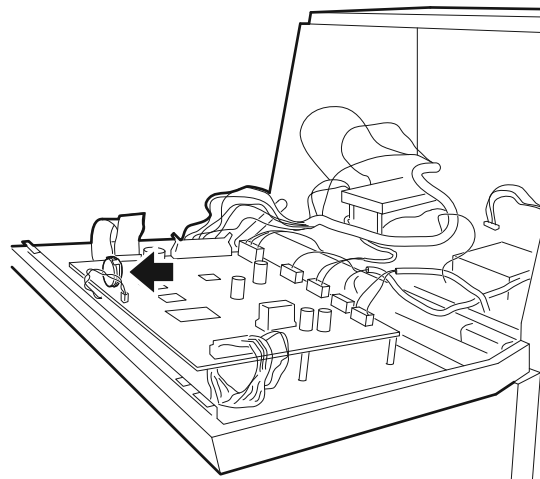

- 
- 3** Remove the battery, and disposal of batteries and accumulators correctly at your local community waste collection / recycling center.

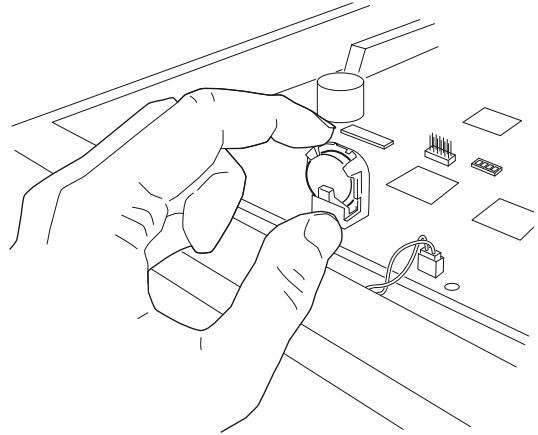

## Periodic Replacement Parts

Product Name		Model	Replacement Period	Number
Nozzle gasket		JCCS-MP-NZL-PK1	1,000 hours (Turn ON time), or the gutter has been closed 2,000 times, or if damaged	1
Ink filter (3 μm)		JCCS-MP-INKFIL2-3.0	The following expiration date, or when it is clogged Dye ink : 3,000 hours(Turn ON time) Pigment ink : 1,500 hours(Turn ON time)	1
Air filter		JCCSR-MP-AIRFIL1	Depending on the installation environment	1
Head filter (including 2 head filter O-rings)		JCCS-MP-HDFL1	3,000 hours (Turn ON time), or when it is clogged	1
Ink pump	DPF2-204RA1	DPF-MP-INKPUMP1-2	12,000 hours (Turn ON time)	1
	PD1143B1701	JCCS-MP-INKPUMP6-1	The diaphragm of the circulation pump, apply the expiration date of the "Diaphragm unit or Diaphragm set".	
	PD1143B1702	JCCS-MP-INKPUMP6-2		
	YH1321B11	JCCS-MP-INKPUMP7-1		
	YH1321B12	JCCS-MP-INKPUMP7-2		
Diaphragm unit	ink pump type • DPF2-204RA1	<ul style="list-style-type: none"> <li>Without replacement spacer DPF-MP-DPU1</li> <li>Include replacement spacer DPF-MP-DPU1-2</li> </ul>		Dye ink : 12,000 hours(Turn ON time) Pigment ink : 2,000 hours(Turn ON time)
Diaphragm set	ink pump type • PD1143B1701 • PD1143B1702 • YH1321B11 • YH1321B12	CCS3000-MP-DPSET2		
Backup battery (Lithium coin battery CR2032)		JCCS-MP-BKBT1	1.5 years	1
Air pump		JCCSR-MP-AIRPUMP	4,000 hours (Turn ON time), or if damaged	1
Large circulation filter		CCS3000-MP-CFIL1	1,500 hours (Turn ON time), or when it is clogged	1

The ink pumps (DPF-MP-INKPUMP1-2) also include a diaphragm unit (DPF-MP-DPU1). DPF-MP-DPU1 indicates diaphragm unit to be used for the ink pump only.

The ink pumps (JCCS-MP-INKPUMP1, 2, 3, 4, 5) also include a diaphragm set (CCS3000-MP-DPSET2). CCS3000-MP-DPSET2 indicates diaphragm assy to be used for the ink pump only.

The rate of deterioration of parts depends on the usage frequency or operating time or usage environment . Replacement period is only an estimate.

Some of the above item are not in use for some models. For details, refer to "Ink compatibility table".

## Recommended Spare Parts

Product Name		Model	Number
Ceramic nozzle	40 μ m	JCCS-MP-SNZL40	1
	50 μ m	JCCS-MP-SNZL50	
	60 μ m	JCCS-MP-SNZL60	
	60 μ m (high-speed printing)	JCCS-MP-SNZL60 x 45	
Screws for nozzle (M2-4 mounting screws)		JCCS-MP-SNZL-M2 x 4S	2
Screws for nozzle plate (M2-6 flat fillister head screws)		JCCS-MP-SNZL-M2 x 6A	2
Nozzle gasket		JCCS-MP-NZL-PK1	1
Ink filter (3 μ m)		JCCS-MP-INKFIL2-3.0	1
Air filter		JCCSR-MP-AIRFIL1	1
Head filter (including 2 head filter O-rings)		JCCS-MP-HDFL1	1
Diaphragm unit	ink pump type • DPF2-204RA1	<ul style="list-style-type: none"> <li>• Without replacement spacer DPF-MP-DPU1</li> <li>• Include replacement spacer DPF-MP-DPU1-2</li> </ul>	1
Diaphragm set (Diaphragm assy)	ink pump type • PD1143B1701 • PD1143B1702 • YH1321B11 • YH1321B12	CCS3000-MP-DPSET2	1
Large circulation filter		CCS3000-MP-CFIL1	1

Some of the above item are not in use for some models. For details, refer to "Ink compatibility table".

# 8 Troubleshooting

## Q&A

### Printing Trouble

#### Printing is Missed On the Low-bias Side

Cause	Solution
<ul style="list-style-type: none"><li>• There are lumps of ink in the gutter edge, blocking the ink spray.</li></ul>	<ul style="list-style-type: none"><li>• The ink spray direction has not been correctly adjusted, so when printing the ink strikes the gutter, and lumps of ink gradually build up in the gutter edge. Clean around the gutter using cleaning solvent, and check the ink flow direction.</li></ul> <p>Related Items</p> <ul style="list-style-type: none"><li>P166: Cleaning the Gutter and the Ink Outlet</li><li>P172: Adjusting the Ink Flow Direction</li></ul>
<ul style="list-style-type: none"><li>• Ink pressure is not correctly adjusted.</li></ul>	<ul style="list-style-type: none"><li>• Adjust using the pressure adjustment screw so that the ink pressure value displayed in the unit test screen is correct.</li></ul> <p>Related Items</p> <ul style="list-style-type: none"><li>P151: Weekly Inspections</li><li>P189: Adjusting Ink Pressure</li></ul>
<ul style="list-style-type: none"><li>• Nozzle is dirty.</li></ul>	<ul style="list-style-type: none"><li>• Remove the nozzle, and clean using cleaning fluid.</li></ul> <p>Related Items</p> <ul style="list-style-type: none"><li>P169: Cleaning the Nozzle</li></ul>

#### Printing is Missed On the High-bias Side

Cause	Solution
<ul style="list-style-type: none"><li>• Ink pressure is not correctly adjusted.</li></ul>	<ul style="list-style-type: none"><li>• Adjust using the pressure adjustment screw so that the ink pressure value displayed in the unit test screen is correct.</li></ul> <p>Related Items</p> <ul style="list-style-type: none"><li>P151: Weekly Inspections</li><li>P189: Adjusting Ink Pressure</li></ul>
<ul style="list-style-type: none"><li>• Nozzle is dirty.</li></ul>	<ul style="list-style-type: none"><li>• Remove the nozzle, and clean using cleaning fluid.</li></ul> <p>Related Items</p> <ul style="list-style-type: none"><li>P169: Cleaning the Nozzle</li></ul>

## Printing Is Unclear

Cause	Solution
<ul style="list-style-type: none"> <li>Print distance (i.e., distance between the print head and the job) is too great.</li> </ul>	<ul style="list-style-type: none"> <li>Make the distance between the print head and the job as close as possible.</li> </ul>
<ul style="list-style-type: none"> <li>There is trembling in the print head and head cable. Or, the conveyer is snaking.</li> </ul>	<ul style="list-style-type: none"> <li>Remove the trembling or snaking.</li> </ul>
<ul style="list-style-type: none"> <li>The interspacing set value between print conditions is too small.</li> </ul>	<ul style="list-style-type: none"> <li>Select the maximum possible interspacing value to set.</li> </ul>
<ul style="list-style-type: none"> <li>Either the electrodes or nozzle areas are dirty, or there is ink adhesion.</li> </ul>	<ul style="list-style-type: none"> <li>Remove and clean the dirty parts using cleaning fluid. After cleaning, dry the area thoroughly.</li> </ul> <p>Related Items</p> <ul style="list-style-type: none"> <li>P163: Cleaning the Electrode Unit</li> <li>P166: Cleaning the Gutter and the Ink Outlet</li> </ul>
<ul style="list-style-type: none"> <li>The ink pressure value is unsuitable, so the ink droplets are not created correctly.</li> </ul>	<ul style="list-style-type: none"> <li>Adjust using the pressure adjustment screw so that the ink pressure value displayed in the unit test screen is correct.</li> </ul> <p>Related Items</p> <ul style="list-style-type: none"> <li>P151: Weekly Inspections</li> <li>P189: Adjusting Ink Pressure</li> </ul>
<ul style="list-style-type: none"> <li>Nozzle is dirty.</li> </ul>	<ul style="list-style-type: none"> <li>Remove the nozzle, and clean using cleaning fluid.</li> </ul> <p>Related Items</p> <ul style="list-style-type: none"> <li>P169: Cleaning the Nozzle</li> </ul>

## No Printing

Cause	Solution
<ul style="list-style-type: none"> <li>Printing enabled status has not been reached. (Printing possible lamp is still flashing.)</li> </ul>	<ul style="list-style-type: none"> <li>If the printing possible lamp is still flashing, wait a little longer. (If the printing possible lamp does not stop flashing, check that the head cover is mounted correctly.)</li> </ul>
<ul style="list-style-type: none"> <li>The "Run" key on the control panel has not been pressed.</li> </ul>	<ul style="list-style-type: none"> <li>Press the "Run" key to enable printing.</li> </ul>

## No Printing

Cause	Solution
<ul style="list-style-type: none"> <li>There are lumps of ink in the gutter edge or the deflection electrode, blocking the ink spray.</li> </ul>	<ul style="list-style-type: none"> <li>The ink spray direction has not been correctly adjusted, so when printing the ink strikes the gutter or the deflection electrode, and lumps of ink gradually build up in the gutter edge. Adjust the position where the ink flow enters the gutter, and clean the areas around the gutter, the ink outlet, and deflection electrode using cleaning fluid.</li> </ul> <p>Related Items</p> <ul style="list-style-type: none"> <li>P163: Cleaning the Electrode Unit</li> <li>P166: Cleaning the Gutter and the Ink Outlet</li> </ul>
<ul style="list-style-type: none"> <li>The print position settings are unsuitable, and printing is not on the job.</li> </ul>	<ul style="list-style-type: none"> <li>Change the photoelectric sensor position, print command from the external I/O, or the print position conditions.</li> </ul>
<ul style="list-style-type: none"> <li>The photoelectric sensor does not operate correctly.</li> </ul>	<ul style="list-style-type: none"> <li>If the photoelectric sensor LED is not lit, the photoelectric sensor cable may be broken, or the connector is not correctly connected. (It is possible that the photoelectric sensor mounting position or direction is misaligned and not performing detection correctly.)</li> </ul>
<ul style="list-style-type: none"> <li>If using a rotary encoder, the set rotation direction is reversed.</li> </ul>	<ul style="list-style-type: none"> <li>Correctly set the rotary encoder rotation direction to clockwise (CW) or counter-clockwise (CCW) using the head settings menu.</li> </ul>

## Print Head Trouble

### Ink Spray Direction Is Unstable

Cause	Solution
<ul style="list-style-type: none"> <li>Dust or ink block is adhering near the ink outlet.</li> </ul>	<ul style="list-style-type: none"> <li>Check whether any dust or ink block is adhering near the ink outlet. Clean the gutter and the ink outlet using cleaning solvent.</li> </ul> <p>Related Items</p> <ul style="list-style-type: none"> <li>P166: Cleaning the Gutter and the Ink Outlet</li> </ul>
<ul style="list-style-type: none"> <li>Air is mixed in the tubes or the gun.</li> </ul>	<ul style="list-style-type: none"> <li>Perform the bleed process using the unit output test.</li> </ul> <p>Related Items</p> <ul style="list-style-type: none"> <li>P185: Bleed Processing</li> </ul>

---

## Ink Spray Direction Is Unstable

Cause	Solution
<ul style="list-style-type: none"><li>Contaminants are jammed in the nozzle pores.</li></ul>	<ul style="list-style-type: none"><li>Remove the nozzle, and clean using cleaning fluid. If this does not solve the problem, wash the nozzle using an ultrasonic cleaner.</li></ul> <p>Related Items</p> <p>P169: Cleaning the Nozzle</p>
<ul style="list-style-type: none"><li>Nozzle sealing does not fully close.</li></ul>	<ul style="list-style-type: none"><li>Adjust the nozzle sealing to fully closed.</li></ul> <p>Related Items</p> <p>P175: Adjusting the Fully-closed Nozzle Sealing</p> <p>P179: Replacing the Nozzle Gasket in the Nozzle Palette</p> <p>P181: Checking and Adjusting the Clearance between the Gutter and Nozzle</p>
<ul style="list-style-type: none"><li>Nozzle is not correctly mounted.</li></ul>	<ul style="list-style-type: none"><li>Remount the nozzle correctly.</li></ul> <p>Related Items</p> <p>P169: Cleaning the Nozzle</p>

## Gutter Does Not Open or Close

Cause	Solution
<ul style="list-style-type: none"><li>Ink has adhered and hardened on the gutter spindle and guide.</li></ul>	<ul style="list-style-type: none"><li>Wash the gutter spindle and guide using cleaning fluid. Alternatively, open and close the gutter repeatedly using the unit output test.</li></ul>
<ul style="list-style-type: none"><li>The spindle connector screw is loose.</li></ul>	<ul style="list-style-type: none"><li>Please contact us.</li></ul>

---

## Ink Is Leaking from the Head

Cause	Solution
<ul style="list-style-type: none"> <li>The nozzle is not correctly mounted, and ink is leaking from the gap with the gun.</li> </ul>	<ul style="list-style-type: none"> <li>Remount the nozzle correctly.</li> </ul> <p>Related Items P169: Cleaning the Nozzle</p>
<ul style="list-style-type: none"> <li>Ink spray direction is greatly misaligned.</li> </ul>	<ul style="list-style-type: none"> <li>Check whether any dust or ink block is adhering near the ink outlet. Clean the gutter and the ink outlet using cleaning solvent. Perform the bleed process using the unit output test. If the trouble is not settled, clean the nozzle, and adjust the ink flow direction.</li> </ul> <p>Related Items P166: Cleaning the Gutter and the Ink Outlet P185: Bleed Processing P169: Cleaning the Nozzle P172: Adjusting the Ink Flow Direction P181: Checking and Adjusting the Clearance between the Gutter and Nozzle</p>
<ul style="list-style-type: none"> <li>Gutter is not collecting the ink.</li> </ul>	<ul style="list-style-type: none"> <li>Ink has hardened in the gutter. Press the tip of the cleaning bottle into the mouth of the gun, and thoroughly irrigate the gutter with the cleaning fluid. If this does not solve the problem, the ink pump needs to be washed. Please contact us.</li> </ul>
<ul style="list-style-type: none"> <li>Nozzle sealing does not fully close.</li> </ul>	<ul style="list-style-type: none"> <li>Adjust the nozzle sealing to fully closed.</li> </ul> <p>Related Items P175: Adjusting the Fully-closed Nozzle Sealing P179: Replacing the Nozzle Gasket in the Nozzle Palette</p>
<ul style="list-style-type: none"> <li>Nozzle seems slightly jammed.</li> </ul>	<ul style="list-style-type: none"> <li>Perform the bleed process using the unit output test screen.</li> </ul> <p>Related Items P185: Bleed Processing</p>

---

## Main Unit Trouble

### Ink Pressure Does Not Reach Set Value

Cause	Solution
<ul style="list-style-type: none"><li>Ink pressure setting is incorrect.</li></ul>	<ul style="list-style-type: none"><li>Adjust using the pressure adjustment screw so that the ink pressure value displayed in the unit test screen is correct.</li></ul> <p>Related Items P189: Adjusting Ink Pressure</p>
<ul style="list-style-type: none"><li>Ink has hardened in the ink pump, ink supply valve, or the solvent supply valve.</li></ul>	<ul style="list-style-type: none"><li>The pump or the valve must be either cleaned or replaced. Please contact us.</li></ul>
<ul style="list-style-type: none"><li>Ink has hardened in the ink ON/OFF valve or the bleed valve.</li></ul>	<ul style="list-style-type: none"><li>The valve must be either cleaned or replaced. Please contact us.</li></ul>
<ul style="list-style-type: none"><li>Ink has hardened in the ink pump.</li></ul>	<ul style="list-style-type: none"><li>The pump must be either cleaned or replaced. Please contact us.</li></ul>
<ul style="list-style-type: none"><li>Ink filter element service life.</li></ul>	<ul style="list-style-type: none"><li>Replace the filter element.</li></ul> <p>Related Items P192: Replacing the Ink Filter</p>
<ul style="list-style-type: none"><li>The ink pump motor temperature is abnormally high.</li></ul>	<ul style="list-style-type: none"><li>The motor must be either repaired or replaced. Please contact us.</li></ul>

### Ink Is Leaking from the Unit

Cause	Solution
<ul style="list-style-type: none"><li>Tube has come free from the joint.</li></ul>	<ul style="list-style-type: none"><li>Please contact us.</li></ul>
<ul style="list-style-type: none"><li>By the stress relaxation, the tightening force of the joint screw portion is weakened.</li></ul>	<ul style="list-style-type: none"><li>Please tighten the joint. If you still have trouble, contact us.</li></ul>

### Ink Lamp Is Flashing

Cause	Solution
<ul style="list-style-type: none"><li>The ink in the ink tank and/or the solvent in the solvent tank is insufficient.</li></ul>	<ul style="list-style-type: none"><li>Fill the ink and/or solvent tank.</li></ul>
<ul style="list-style-type: none"><li>Ink has hardened in the ink pump, ink supply valve, or the solvent supply valve.</li></ul>	<ul style="list-style-type: none"><li>Please contact us.</li></ul>

## Alarm Lamp Is Lit

Cause	Solution
<ul style="list-style-type: none"> <li>Ink pressure value is incorrect.</li> </ul>	<ul style="list-style-type: none"> <li>Correctly adjust the ink pressure using the pressure adjustment screw. If the pressure cannot be adjusted using the screw, please contact us.</li> </ul> <p>Related Items P189: Adjusting Ink Pressure</p>
<ul style="list-style-type: none"> <li>The charge electrode is either dirty or malfunctioning, and the ink droplets are not being charged correctly.</li> </ul>	<ul style="list-style-type: none"> <li>Wash the electrode using cleaning fluid. If the electrode is malfunctioning, it must be replaced. Please contact us.</li> </ul>
<ul style="list-style-type: none"> <li>The detector electrode is either dirty or malfunctioning, and is not detecting correctly.</li> </ul>	<ul style="list-style-type: none"> <li>Wash the electrode using cleaning fluid. If the electrode is malfunctioning, it must be replaced. Please contact us.</li> </ul>

## The Print Enabled Lamp Is Constantly ON

Cause	Solution
<ul style="list-style-type: none"> <li>Head cover is not correctly mounted.</li> </ul>	<ul style="list-style-type: none"> <li>Mount the head cover correctly.</li> </ul>
<ul style="list-style-type: none"> <li>Piezo element is malfunctioning.</li> </ul>	<ul style="list-style-type: none"> <li>Check whether the cable for the Piezo element at the back of the gun is broken. If the cable is broken, the Piezo element itself may be damaged. Please contact us.</li> </ul>

## Set Data Is Initialized

Cause	Solution
<ul style="list-style-type: none"> <li>The battery on the main board has worn out, or part of the set data is corrupted.</li> </ul>	<ul style="list-style-type: none"> <li>Check whether the battery is worn.</li> </ul> <p>Related Items P200: Replacing the Backup Battery</p>

## Display Panel Trouble

### Power Supply Will Not Turn ON



Cause	Solution
<ul style="list-style-type: none"> <li>Main power supply is not turned ON.</li> </ul>	<ul style="list-style-type: none"> <li>Turn ON the main power supply.</li> </ul>
<ul style="list-style-type: none"> <li>Other reasons.</li> </ul>	<ul style="list-style-type: none"> <li>Please contact us.</li> </ul>

---

## Backlight Will Not Light

### Cause

### Solution

- |   |   |
|---|---|
| <ul style="list-style-type: none"><li>• The keys have not been pressed for a while, so the backlight has turned OFF automatically.</li></ul>  | <ul style="list-style-type: none"><li>• Press the keys on the control panel.</li></ul>  |
| <ul style="list-style-type: none"><li>• The backlight is lit, but the screen contrast is set too low, and so appears not to be lit.</li></ul> | <ul style="list-style-type: none"><li>• Adjust the contrast, push  or .</li></ul> |
-

# Error Codes and History Codes

## Code Tables

The causes and check details if an error code defined by the CCS-R occurs are described below. Further, the first digit of each code describes the code classification.

Value	Classification	Meaning
1,3	History	History of operating state.
1	Error	When these errors occur, data setting and/or communication with the host does not function well.
7	Alarm	Printing has stopped due to a fatal nonconformance in the print operation.
7	Warning	The print operation continues, but the problem should be solved as soon as possible.

Code	Meaning	Details Page
1100	Power supply ON	221
1110	Power supply OFF	221
1120	Run	221
1130	Stop	221
16E0	Set system clock	221
3210	Data initialization	221
1300	Imaging size exceeded	221
1330	Rotary Encoder division error	221
1340	Outside entry range	221
1344	Module length error	222
1345	divid error	222
1349	Speed error	222
134A	Message storage area overflow	222
134B	No. of messages exceeded	222
1680	FROM verify error	222
1690	FROM deletion error	222
16A0	FROM write error	222
1500	Overrun error	223
1510	Framing error	223
1520	Parity error	223
1530	Receiving buffer full	223
1540	Receiving timeout	223
1560	Command error	223
1570	Command format error	223
1581	Printing not possible	223
15B0	Command implementation not possible (boot)	224
15B1	Command implementation not possible (head)	224
15B2	Command implementation not possible (gutter)	224
15B3	Command implementation not possible (unit)	224

<b>Code</b>	<b>Meaning</b>	<b>Details Page</b>
15B4	Address error	224
15B5	Incompatible data	224
15C1	Check sum error	224
1411 1415	Print abnormality forecast warning error	225
74F1	Detection time tolerances exceeded	225
7630	FONT ROM error	225
7651	Viscosity measurement system malfunction	225
76F4	Viscosity measurement system error	226
76F6	Viscosity measurement system error	226
76F7	Viscosity measurement system error	226
7401	Charge detection time OUT	228
7409	Head temperature error	228
7411 7415	Print defect forecast warning	228
7421	Ink leak from pump	228
7441	Ink empty (main tank)	229
7451	Deflection electrode leak detected	229
7461	Electrification error (start/not detected)	230
74A1	Electrification error (start/ detected)	231
74B1	Electrification error (start/ defective electrode)	231
74C1	Electrification error (during operation/not detected)	231
74D1	Electrification error (during operation/ detected)	232
7471	Gutter error	233
7481	Solvent empty	234
7600	System clock error	234
7620	Electrification RAM error	234
7661	Photoelectric sensor monitoring error	234
76C0	Battery voltage low	234

## History Code Details

**Code 1100** Power supply ON

Shows that the power supply has been turned ON.

**Code 1110** Power supply OFF

Shows that the power supply has been turned OFF.

**Code 1120** Run

Shows that the printing-head has been run.

**Code 1130** Stop

Shows that the printing-head has been stopped.

**Code 16E0** Set system clock

Shows that the system clock has been set.

**Code 3210** Data initialization

Shows that the data has been initialized.

## Error Code Details

### ■ Data Settings Codes

**Code 1300** Imaging size exceeded

Cause	Solution
The setting exceeds the size that can be printed for one character.	Change the settings.

**Code 1330** Encoder division error

Cause	Solution
The distance and number of pulses per rotation in the rotary encoder parameters are illegal.	Correct the set values.

**Code 1340** Outside entry range

Cause	Solution
The set values are outside the range when set.	Correct the set values.

<b>Code</b> 1344	<b>Module length error</b>
<b>Cause</b>	<b>Solution</b>
Too many characters have been registered to one module	Check the number of registered characters.

<b>Code</b> 1345	<b>divid error</b>
<b>Cause</b>	<b>Solution</b>
An impossible print speed has been specified.	Change the speed, horizontal dot pitch, interspacing, and number of scan dots per character, etc., in the print conditions.

<b>Code</b> 1349	<b>Speed error</b>
<b>Cause</b>	<b>Solution</b>
An impossible print speed has been specified.	Change the speed, horizontal dot pitch, interspacing, and number of scan dots per character, etc., in the print conditions.

<b>Code</b> 134A	<b>Message storage area overflow</b>
<b>Cause</b>	<b>Solution</b>
The message storage area is insufficient.	Delete unused messages.

<b>Code</b> 134B	<b>No. of messages exceeded</b>
<b>Cause</b>	<b>Solution</b>
An illegal message number has been selected.	Select a usable message.

## ■ Memory Errors

<b>Code</b> 1680	<b>FROM verify error</b>
<b>Cause</b>	<b>Solution</b>
A verify error occurred during writing.	FROM-IC is malfunction, or IC's life is over. Replace the main board.

<b>Code</b> 1690	<b>FROM deletion error</b>
<b>Cause</b>	<b>Solution</b>
A nonconformance occurred while deleting before writing.	FROM-IC is malfunction, or IC's life is over. Replace the main board.

<b>Code</b> 16A0	<b>FROM write error</b>
<b>Cause</b>	<b>Solution</b>
A nonconformance occurred during writing.	FROM-IC is malfunction, or IC's life is over. Replace the main board.

## ■ Communications Errors

<b>Code</b> 1500	<b>Overrun error</b>	
<b>Cause</b>	<b>Solution</b>	
A communications error occurred.	Review the communications conditions, communications cable, and the connections.	
<b>Code</b> 1510	<b>Framing error</b>	
<b>Cause</b>	<b>Solution</b>	
A communications error occurred.	Review the communications conditions, communications cable, and the connections.	
<b>Code</b> 1520	<b>Parity error</b>	
<b>Cause</b>	<b>Solution</b>	
A communications error occurred.	Review the communications conditions, communications cable, and the connections.	
<b>Code</b> 1530	<b>Receiving buffer full</b>	
<b>Cause</b>	<b>Solution</b>	
Sent data exceeds the receiving buffer size.	Reduce the size of the data sent.	
<b>Code</b> 1540	<b>Receiving timeout</b>	
<b>Cause</b>	<b>Solution</b>	
The interval of send data became 3 seconds or more.	Shorten the interval of send data.	
<b>Code</b> 1560	<b>Command error</b>	
<b>Cause</b>	<b>Solution</b>	
Command is illegal.	Check the command.	
<b>Code</b> 1570	<b>Command format error</b>	
<b>Cause</b>	<b>Solution</b>	
Format is illegal.	Check the format.	
<b>Code</b> 1581	<b>Printing not possible</b>	
<b>Cause</b>	<b>Solution</b>	
Printing is not possible, or printing is currently being performed so other printing cannot be performed.	Check the head operation status and enable the print head.	

<b>Code</b> 15B0	<b>Command implementation not possible (boot)</b>
<b>Cause</b>	<b>Solution</b>
A boot software communications command was received.	Check the command.
<b>Code</b> 15B1	<b>Command implementation not possible (head)</b>
<b>Cause</b>	<b>Solution</b>
A command that cannot be processed during operations was received.	Stop the machine, and then resend.
<b>Code</b> 15B2	<b>Command implementation not possible (gutter)</b>
<b>Cause</b>	<b>Solution</b>
A command that cannot be processed during gutter operations was received.	Stop the machine, and then resend.
<b>Code</b> 15B3	<b>Command implementation not possible (unit)</b>
<b>Cause</b>	<b>Solution</b>
A command that can be processed only while the unit is stopped was received.	Stop the machine, and then resend.
<b>Code</b> 15B4	<b>Address error</b>
<b>Cause</b>	<b>Solution</b>
Incorrect address specified.	Check the command.
<b>Code</b> 15B5	<b>Incompatible data</b>
<b>Cause</b>	<b>Solution</b>
Data is incompatible.	Check the command.
<b>Code</b> 15C1	<b>Check sum error</b>
<b>Cause</b>	<b>Solution</b>
Communications check sum does not agree.	Check the command.

## Warning Code Details

Code 1411 Code 1415		Print abnormality forecast warning error	
Status	Cause	Solution	
—	The phase adjustment is unstable and the character spacing is too short, so the time for phase adjustment cannot be assured. (A print signal was entered while the detection time was being adjusted, causing a no-print.)	Replace the nozzle and check the character spacing.	
<b>Remarks</b> This code was registered using "Record" in "No-Print Check" of the "Unit Config" of the "Config". When this setting is enabled, check the phasing status immediately before a print command is received and printing is performed. If there is a possibility of defective printing, stop printing and perform registration. The likelihood of a print defect is less than 1%, so it is recommended to disable the "No-print check".			
Code 74F1		Detection time tolerances exceeded	
Status	Cause	Solution	
The set range for the charge detection time was exceeded.	Ink viscosity changed.	Check ink viscosity changes, and adjust if any changes have occurred. Adjust (compensate) the charge detection time.	
Code 7630		FONT ROM error	
Status	Cause	Solution	
—	Whether the font data is corrupted is not registered.	Install the font data.	
Code 7651		Viscosity measurement system malfunction	
Status	Cause	Solution	
The bottom sensor and the top sensor were ON during ink replenishment to the capillary viscometer.	The sensor malfunction.	Replace the sensor.	

<b>Code 76F4 Viscosity measurement system error</b>		
<b>Status</b>	<b>Cause</b>	<b>Solution</b>
The bottom sensor and the top sensor were OFF during viscosity measurement. (If the bottom sensor does not turn ON within 120s after the top sensor turns OFF.)	Main tank level is rising.	Wait until level falls.
	The ink viscosity is very high.	Wait until viscosity falls.
	The sensor malfunction, or the orifice of falling ink is clogged up.	Replace the sensor, or clean the capillary viscometer.

<b>Code 76F6 Viscosity measurement system error</b>		
<b>Status</b>	<b>Cause</b>	<b>Solution</b>
The bottom sensor was OFF and the top sensor was ON during viscosity measurement. (If the top sensor do not turn OFF within 120s after supply has stopped.)	Main tank level is rising.	Wait until level falls.
	The ink viscosity is very high.	Wait until viscosity falls.
	The sensor malfunction, or the orifice of falling ink is clogged up.	Replace the sensor, or clean the capillary viscometer.

<b>Code 76F7 Viscosity measurement system error</b>		
<b>Status</b>	<b>Cause</b>	<b>Solution</b>
Uniformity time passed after CCS-R started, but the float was reaching bottom.	The float can not rise by ink.	Perform normalization, or clean the float.
	The sensor malfunction.	Replace the sensor.

## ■ Status and Troubleshooting During Capillary Viscometer Sensor Misoperation

The sensors used in the capillary viscometer may misoperate. Consequently, the CCS-R monitors sensor misoperations before viscosity measurements, during ink supply to the capillary viscometer, and at each phase during viscosity measurements. A simple explanation is given below.

### Top and Bottom Sensor Status and Error Codes

Phase	Sensor		Status	Code
	Bottom	Top		
(During viscosity measurement) Before measuring starts	ON	OFF	Normal	
	OFF	OFF	Normal (Main tank level is rising)	
	OFF	ON	Normal (Main tank level is rising)	
	ON	ON	• Sensor is malfunctioning.	7651
(During viscosity measurement) Ink supply operation	ON	OFF	• If this status continues 120s after the start of supply, either the ink has run out or the sensors is malfunctioning.	7441
	OFF	OFF	• If this status continues 120s after the start of supply, either the ink has run out or the top sensor is malfunctioning.	7441
	OFF	ON	Normal (replenishment completed)	
	ON	ON	• Sensor is malfunctioning.	7651
(During viscosity measurement) Viscosity measuring operations	ON	OFF	Normal (measuring completed)	
	OFF	OFF	• If the bottom sensor does not turn ON within 120s after the top sensor turns OFF. (i.e., Main tank level is rising, or viscosity is very high.) • Sensor is malfunctioning, or orifice of falling ink is clogged up.	76F4 Measuring stopped
	OFF	ON	• If the top sensor do not turn OFF within 120s after supply has stopped. (i.e., Main tank level is rising, or viscosity is very high.) • Sensor is malfunctioning, or orifice of falling ink is clogged up.	76F6 Measuring stopped
	ON	ON	• Sensor is malfunctioning.	7651 Measuring stopped
(During sensor normalization of starting) Sensor normalization	ON	OFF	• Even if sensor normalization is performed ten times after CCS-R started, the sensor is not normal.	76F7

---

## Alarm Code Details

Code	<b>7401</b>	<b>Charge detection time OUT</b>
------	-------------	----------------------------------

Meaning	Solution
The charge detection time was largely misaligned from the set value ( $\pm 00$ sec) due to atmospheric temperature changes.	Operate the head again.

Code	<b>7409</b>	<b>Head temperature error</b>
------	-------------	-------------------------------

Meaning	Solution
Head temperature exceeded the head temperature limit.	Adjust the head to be below the temperature limit.

Code	<b>7411</b> <b>7415</b>	<b>Print defect forecast warning</b>
------	----------------------------	--------------------------------------

Meaning	Solution
The phase adjustment is unstable and the character interval is too short, so the time for phase adjustment cannot be assured. (A print signal was entered while the detection time was being adjusted, causing a no-print.)	Replace the nozzle and check the character spacing.

### Remarks

This code was registered using "Warning" in "No-Print Check" of the "Unit Config" of the "Config". When this setting is enabled, check the phasing status immediately before a print command is received and printing is performed. If there is a possibility of defective printing, stop printing and perform registration. The likelihood of a print defect is less than 1%, so it is recommended to disable the "No-print check".

Code	<b>7421</b>	<b>Ink leak from pump</b>
------	-------------	---------------------------

Meaning	Solution
The ink leak out from the ink pump.	Check the ink pump. If ink leak out from the ink pump, repair or replace the ink pump.

### Remarks

This function is only when the sensor of ink-leak detection mounted to the ink pump.

Code 7441

## Ink empty (Main tank)

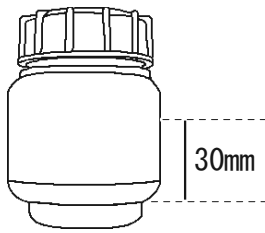
Status	Cause	Solution
Ink tank is empty.	The ink has run out.	Replenish the ink, and press the "Refill" key. If the ink is filled to a set level, the function will end automatically.
The level in the main tank is below 30 mm.	The main tank level sensor is abnormal.	Check the harness connection. If there is no problem, there may be a malfunction.
	Ink fill line abnormality.	Replenish the ink, and press the "Refill" key. If the ink is filled to a set level, the function will end automatically. If ink is not being replenished, repairs are necessary.
	Supply line to the capillary viscometer is abnormal.	Switch to unit test, press the "Measure" key, and check the supply time. If the supply takes too long, repairs such as cleaning the supply line are necessary.
The level in the main tank is above 30 mm.	Supply line to the capillary viscometer is abnormal.	Switch to unit test, press the "Measure" key, and check the supply time. If the supply takes too long, repairs such as cleaning the supply line are necessary.
The level in the main tank is about 40 mm.	Supply line to the capillary viscometer is abnormal.	Check the harness connection, and if there is a problem, repairs are necessary. If there is no problem, switch to unit test, press the "Measure" key, and check the capillary viscometer sensor ON/OFF operation. If a misoperation occurs, repairs are necessary.

Code 7451

## Deflection electrode leak detected

Status	Cause	Solution
Ink has dirtied the inside of the head.	There may be leaks due to ink dirt.	Clean inside the head.
Inside of the head is clean.	The deflection electrode is damaged, or the deflection electrode cable is malfunctioning.	Check whether the deflection electrode is damaged, or the deflection electrode cable is malfunctioning.

---

Code **7461**

**Electrification error (start/not detected)**

<b>Status</b>	<b>Cause</b>	<b>Solution</b>
<b>Electrification was detected not even once during phasing at operations startup, and the Piezo voltage reached its maximum value.</b>	<b>The electrification detector electrode is dirty with ink or solvent.</b>	<b>Clean using cleaning solvent, and then dry completely.</b>
	<b>Ink does not spray correctly.</b>	<b>Improve the ink spray direction.</b>
	<b>Charge electrode has fallen.</b>	<b>Remove the electrode fixing jig.</b>
	<b>The charge detector electrode cable is jutting out, and the charge detector electrode has not fallen completely.</b>	<b>Improve cable nonconformance.</b>
	<b>The (two) charge detector electrode cables are broken.</b>	<b>Improve cable nonconformance.</b>
	<b>Electrification voltage signals are not output.</b>	<b>Main board nonconformance. (Voltage must be adjusted.)</b>
	<b>Piezo cable is broken.</b>	<b>Improve cable nonconformance.</b>
	<b>Piezo voltage is not output.</b>	<b>Main board nonconformance. (Voltage must be adjusted.)</b>
	<b>Ink adhering to the cap is adhering to the charge electrode and the electrode is conducting when the gutter is opened.</b>	<b>Clean the cap using solvent.</b>

Code **74A1****Electrification error (start/ detected)**

Status	Cause	Solution
Electrification was detected during phasing at operations startup, but the Piezo voltage reached its maximum value.	The charge detector electrode is dirty with ink or solvent, and so the detector electrode cannot perform stable detection.	Clean using cleaning solvent, and then dry completely.
	Ink pressure values are not suitable.	Adjust the ink pressure to a suitable value.
	Charge detection time is not suitable.	Adjust the charge detection time to a suitable value.
	Ink viscosity is abnormal. (Measured values are not suitable.)	Adjust the ink viscosity.
	Actual ink viscosity has fallen due to a viscosity measuring system malfunction.	Clean the capillary viscometer orifice.
	Suitable droplets cannot be formed due to a nozzle nonconformance.	Clean the nozzle ultrasonically. If the problem is not solved, replace the nozzle.
	The maximum Piezo voltage value is not suitable.	Adjust the maximum Piezo voltage value.
	Ink temperature is not suitable.	Wait until the ink temperature is balanced.

Code **74B1****Electrification error (start/ defective electrode)**

Status	Cause	Solution
Electrification was detected before the charge was output during phasing at operations startup.	The charge detector electrode is dirty with ink or solvent, and the detection signal is always ON.	Clean using cleaning solvent, and then dry completely.
	The core wire of the detector electrode has been grounded and short-circuited.	Measure the resistance between the detector electrode and ground, and if there is a short-circuit, replace the electrode.

Code **74C1****Electrification error (during operation/not detected)**

Status	Cause	Solution
There was no electrification detection during operations for certain period of time.	The ink spray direction was bent during operations due to air and dirt in the nozzle, and the electrode was dirtied with ink.	Clean the nozzle.
	The ink pressure and viscosity changed largely, and the break point is outside the charge electrode.	Check the ink pressure and viscosity for nonconformances.

---

Code **74D1**

**Electrification error (during operation/ detected)**

<b>Status</b>	<b>Cause</b>	<b>Solution</b>
The charge detection time set using real time controls did not occur during operations.	The set charge detection time did not occur due to ink viscosity and pressure fluctuations.	Check the ink viscosity and pressure.

---

Code 7471

## Gutter error

Status	Cause	Solution
Gutter errors occur if the gutter is stopped suddenly using the gutter opening and closing control (i.e., motor current detection), or if the motor current is not detected within 30s.	The slider is jammed with ink.	Clean the slider.
	Slider unit movement is abnormally stiff.	Check the slider unit. (Check the operation with the motor coupling removed.)
	The gutter motor coupling is idling.	Fix the coupling.
	Not connected correctly to the main board CN8.	Check the connector connection.
	Gutter motor cable is broken.	Check the motor cable.
	Gutter motor malfunction.	Check the thermistor solder and the motor.
	Main board nonconformance.	Replace the main board.

### ■ Solving Gutter Errors

Solution: Solve by opening and then closing again the gutter.

- 1** Press the **F1** (Unit Test) key in the alarm screen.

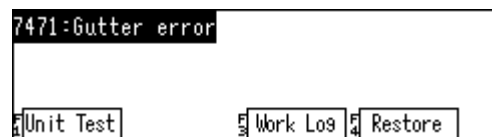

- 2** Next, press the **F2** (Output) key, and then the **F3** (Mainte) key.

- 3** If the slider is dirty, clean using cleaning solvent.

- 4** Turn ON the "Ink on/off valve", "Circulation valve", "Pump", and "Gutter open".

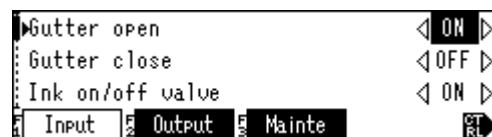

- 5** When the gutter is partly open, turn OFF "Gutter open", and turn ON "Gutter close".

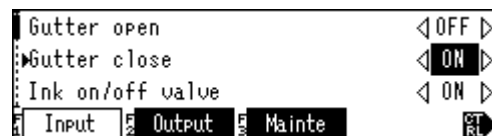

- 6** If the gutter closes normally, press the **Esc** key, and then press the **F4** (Go on) key. This will end the operation.

<b>Code 7481 Solvent empty</b>		
Status	Cause	Solution
The solvent tank is empty.	The solvent has run out.	Replenish the solvent.
Solvent is present.	Solvent supply path is malfunctioning.	Check the solvent supply path. Check the supply operation manually.

<b>Code 7600 System clock error</b>		
Status	Cause	Solution
System clock IC is abnormal.	Influence of the electromagnetic noise, battery service life, and hardware malfunction.	Set the system clock.

<b>Code 7620 Electrification RAM error</b>		
Status	Cause	Solution
Electrification data cannot be written to the electrification RAM. Further, this code is output during initialization when the power supply is turned ON. The hardware is malfunctioning, so force-turn OFF the power supply.	Hardware malfunction.	Turn ON the power supply again. If the problem persists, contact us.

<b>Code 7661 Photoelectric sensor monitoring error</b>		
Status	Cause	Solution
The print command turned ON for a set time.	Jobs are jammed in a queue in front of the job detector due to a line stop.	Start the line.
	Photoelectric sensor is dirty.	Clean the photoelectric sensor.

<b>Code 76C0 Battery voltage low</b>		
Status	Cause	Solution
—	Main board battery service life.	Replace the battery.

## Guarantee

Repairs will be performed free of charge to malfunctions and nonconformances occurring within one year of delivery. The following items, however, are not guaranteed even within 1 year of delivery. Further, consumables are not guaranteed. In addition, any repairs to malfunctions and nonconformances occurring after one year of delivery will be charged regardless of your operating time.

- The use of parts, ink, solvent, etc., not specified by us.
- Malfunction caused by using methods and procedures not described in the user manual.
- Failure to perform inspections specified in the enclosed manual or notebook.
- Failure to follow the precautions described in the enclosed manual or notebook.
- Any other installation that fails to follow the installation precautions specified by us (as described in detail in the basic or advanced manuals).
- Malfunctions caused by fire or acts of God.
- Failures caused by a part whose operating time exceeds the recommended exchange time.



# 9 Specifications

## General Specifications

Item	Specifications
<b>Printing method</b>	Continuous system (Charge control system)
<b>Dust-proof and water-proof performance</b>	IP24
<b>RoHS directive</b>	Compliant
<b>Character height</b>	0.8 ~ 5mm (40 μ m nozzle), 1 ~ 10mm (50 μ m nozzle), 2 ~ 10mm (60 μ m nozzle)
<b>Maximum print speed</b>	1,777~2,666 characters/sec In the case of 5 x 5 dot font, 1 character space. For details, refer to "Ink compatibility table".
<b>Printing material</b>	Paper, metals, plastic, glass, wood, etc.
<b>Character type (for using JAPAN and CHINA)</b>	Alphabet (upper/lower cases), figures, symbols, Katakana and Hiragana, Chinese characters (JIS 1st and 2nd standard), user characters and simplified Chinese characters (GB2312)
<b>Character type (for using other country)</b>	Latin alphabet, figures, symbols (based on MS Windows <sup>(R)</sup> CP1252)
<b>Printing lines and font matrix (height x width)</b>	e.g. 1 ~ 4 lines: 5 x N and 5 x 5 dots 1 ~ 3 lines: 7 x N, 7 x 8 and 7x 5 dots 1 ~ 2 lines: 12 x 10, 10 x 8, 9 x 9, and 9 x 7 dots 1 line: 24 x 24, 24 x 18, 16 x 16 and 16 x 12 dots (Matrix width named 'N' are proportional font.)
<b>Font</b>	Gothic (optional: Mincho)
<b>Number of printed characters</b>	512 characters max.
<b>Number of registered messages</b>	50 messages max.
<b>Date &amp; time (expiration date) print functions</b>	AD year, Japanese era name, year/date, day of week, time (12/24 schedule), annual serial date, annual serial week number, early/middle/late part of month (variable term setting), AM/PM and the replace-character function(replaces year, month, day, time, minute and second with different characters in single-digit)
<b>Numbering function</b>	Max. 8 digits, optional default value setting, up/down, carry (1 count can be set ranging from 1 to 9999 works), zero suppression function (replaces zeros in higher digits with spaces), numbering replace-character function (replaces with characters other than figures)
<b>Barcode printing function</b>	ITF, Code39, NW7, EAN, Code128
<b>Communications function</b>	RS-232C 1ch, 76,800bps max.
<b>External I/O</b>	Input : print commands

Item	Specifications	
Head cable	3.5m	
Nozzle caliber	40 μ m, 50 μ m, 60 μ m	For details, refer to "Ink compatibility table".
Data input	Full keyboard, RS-232C communications	
Grounding	Type D ground	

## Model-Dependent Specifications

### ■ Dye ink unit

Item	Specifications	
External dimensions	Main unit	650mm (Height) x 450mm (Width) x 300mm (Depth)
	Print head	40mm (Height) x 40mm (Width) x 199mm (Depth)
	Weight	30kg
Use environment	0 to 40 degrees centigrade, 10% to 80% RH (with no condensation)	
Power supply	(100VAC)	50/60Hz, 60W max. (80VA)
	(220VAC)	50Hz, 70W max. (100VA)

### ■ Pigment ink unit

Item	Specifications	
External dimensions	Main unit	650mm (Height) x 450mm (Width) x 300mm (Depth)
	Print head	40mm (Height) x 40mm (Width) x 199mm (Depth)
	Weight	30kg
Use environment	0 to 40 degrees centigrade, 10% to 80% RH (with no condensation)	
Power supply	(100VAC)	50/60Hz, 60W max. (80VA)
	(220VAC)	50Hz, 70W max. (100VA)

Operating ambient temperature varies depending on ink type. For details, refer to "Ink compatibility table".

# Characters and Print Specifications

## Standard Fonts

The fonts installed in this machine are as follows.

Character Type	24 x 24	24 x 18	16 x 16	16 x 12	12 x 10	10 x 8	9 x 9
Latin alphabet Numeral Sign	Gothic	Original	Gothic	Original	Original	Original	Original
Arabic alphabet	Original	Original	Original	Original	Original	Original Note 1	Original

Character Type	9 x 7	7 x N	7 x 8	7 x 5	5 x N	5 x 5
Latin alphabet Numeral Sign	Original Note 1	Original Note 1	Original Note 1	Original Note 1	Original Note 1	Original Note 1
Arabic alphabet	Original Note 1	Original Note 2	Original Note 2	Original Note 2	Original Note 2	Original Note 2

Original: CCS-R original fonts are registered

Note 1: Includes font data that is not actually used.

Note 2: The font data is registered, but is not actually used.

## Messages

A maximum of 50 print data (messages) can be registered.

Module Type	Module Outline
Text Module	Normal character strings such as Latin and Arabic alphabet, Numeral, sign, etc.
Calendar Module	Dates and times such as production date and expiry date, etc.
Numbering Module	Prints automatically incremented (decremented) numbers
Barcode Module	Print barcode.
Interval Module	Spaces between modules

## Multi-Step Printing

Multi-step printing in which fonts with different numbers of dots are mixed is also possible.

Various multi-step printing configurations can be set using the print conditions (e.g., number of scan dots, font size, and print position, etc.) Font print position can be set by the user or by specifying the number of steps when creating the message.





### ■ Samples of Images by Number of Steps

A maximum of four steps can be specified, and the print positions from step 2 onwards are determined by the number of scan dots.

Multi-step examples according to the number of scan dots are shown below.

(When specifying the number of steps, a maximum of four steps are allocated evenly using from 16 to 26 vertical dots. If set by the user, the positions can be created as shown in the specifications table.)

#### Number of scan dots 26

Step	Distribution	Font sizes that can be registered	Image
1	1-step (0th dot)	All print orientations: All font sizes	
2	1-step (0th dot) 2-step (13th dot)	Horizontal print orientation: 16 x 12, 7 x N All print orientation: 12 x 10, 10 x 8, 9 x 9, 9 x 7, 7 x N, 7 x 8, 7 x 5, 5 x N, 5 x 5	
3	1-step (0th dot) 2-step (9th dot) 3-step (18th dot)	Horizontal print orientation: 10 x 8, 9 x 7 Vertical print orientation: 7 x N All print orientation: 7 x 8, 7 x 5, 5 x N, 5 x 5	
4	1-step (0th dot) 2-step (6th dot) 3-step (12th dot) 4-step (18th dot)	Horizontal print orientation: 7 x 5 Vertical print orientation: 5 x N All print orientation: 5 x 5	

### Number of scan dots 24

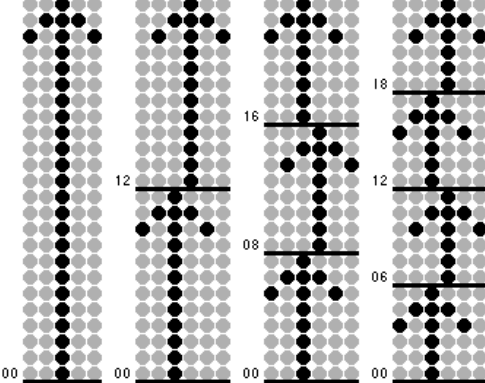
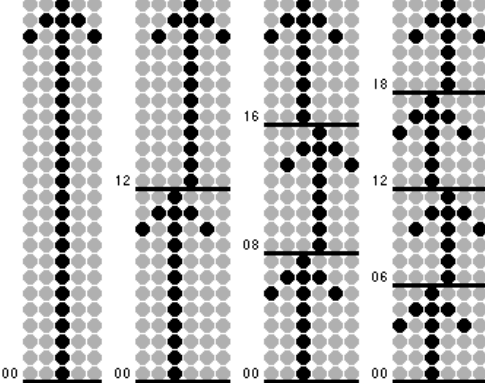
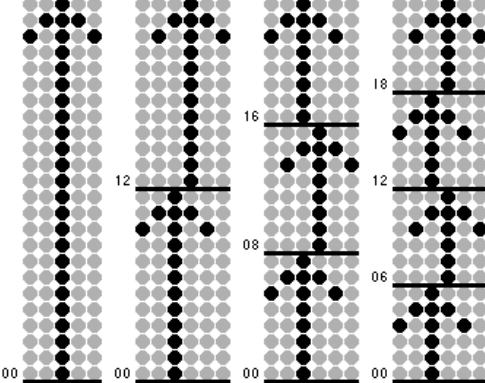
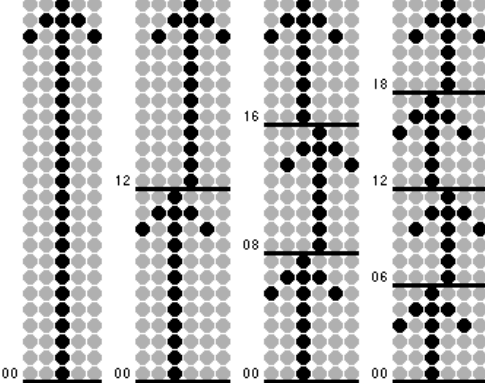
Step	Distribution	Font sizes that can be registered	Image
1	1-step (0th dot)	All print orientations: All font sizes	
2	1-step (0th dot) 2-step (12th dot)	Horizontal print orientation: 16 x 12 All print orientation: 12 x 10, 10 x 8, 9 x 9, 9 x 7, 7 x N, 7 x 8, 7 x 5, 5 x N, 5 x 5	
3	1-step (0th dot) 2-step (8th dot) 3-step (16th dot)	Horizontal print orientation: 10 x 8, 9 x 7 Vertical print orientation: 7 x N All print orientation: 7 x 8, 7 x 5, 5 x N, 5 x 5	
4	1-step (0th dot) 2-step (6th dot) 3-step (12th dot) 4-step (18th dot)	Horizontal print orientation: 7 x 5 Vertical print orientation: 5 x N All print orientation: 5 x 5	

### Number of scan dots 22

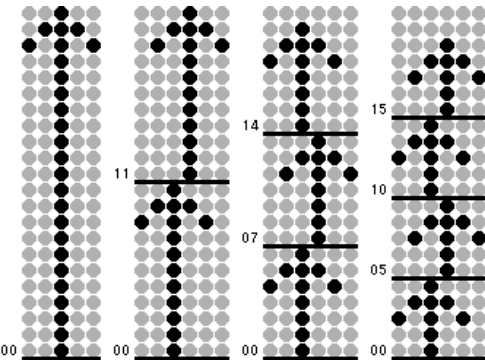
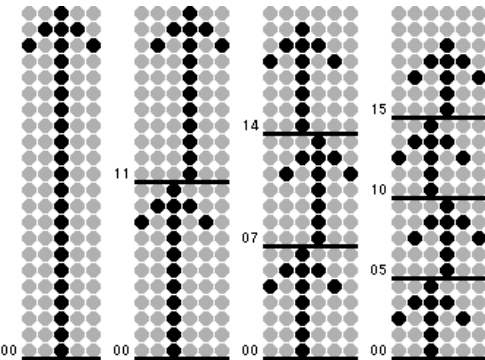
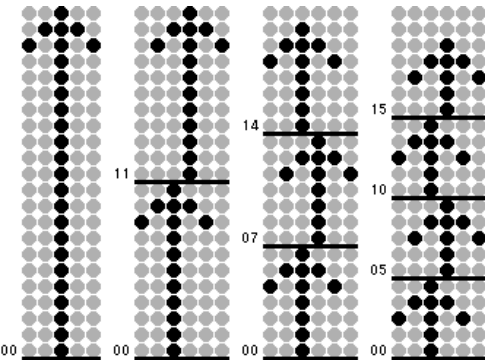
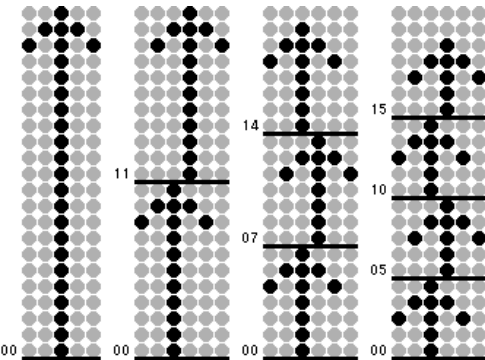
Step	Distribution	Font sizes that can be registered	Image
1	1-step (0th dot)	Horizontal print orientation: 24 x 18 All print orientation: 16 x 16, 16 x 12, 12 x 10, 10 x 8, 9 x 9, 9 x 7, 7 x N, 7 x 8, 7 x 5, 5 x N, 5 x 5	
2	1-step (0th dot) 2-step (11th dot)	Horizontal print orientation: 12 x 10 All print orientation: 10 x 8, 9 x 9, 9 x 7, 7 x N, 7 x 8, 7 x 5, 5 x N, 5 x 5	
3	1-step (0th dot) 2-step (7th dot) 3-step (14th dot)	Horizontal print orientation: 9 x 7 Vertical print orientation: 7 x N, 7 x 8, 5 x N All print orientation: 7 x 5, 5 x 5	
4	1-step (0th dot) 2-step (5th dot) 3-step (10th dot) 4-step (15th dot)	Horizontal print orientation: 7 x 5 Vertical print orientation: 5 x N All print orientation: 5 x 5	

**Number of scan dots 20**

Step	Distribution	Font sizes that can be registered	Image
1	1-step (0th dot)	Horizontal print orientation: 24 x 18 All print orientation: 16 x 16, 16 x 12, 12 x 10, 10 x 8, 9 x 9, 9 x 7, 7 x N, 7 x 8, 7 x 5, 5 x N, 5 x 5	
2	1-step (0th dot) 2-step (10th dot)	Horizontal print orientation: 12 x 10 All print orientation: 10 x 8, 9 x 9, 9 x 7, 7 x N, 7 x 8, 7 x 5, 5 x N, 5 x 5	
3	1-step (0th dot) 2-step (7th dot) 3-step (14th dot)	Horizontal print orientation: 7 x 5 Vertical print orientation: 5 x N All print orientation: 5 x 5	
4	1-step (0th dot) 2-step (5th dot) 3-step (10th dot) 4-step (15th dot)	Horizontal print orientation: 7 x 5 Vertical print orientation: 5 x N All print orientation: 5 x 5	

**Number of scan dots 16**

Step	Distribution	Font sizes that can be registered	Image
1	1-step (0th dot)	All print orientation: 16 x 16, 16 x 12, 12 x 10, 10 x 8, 9 x 9, 9 x 7, 7 x N, 7 x 8, 7 x 5, 5 x N, 5 x 5	
2	1-step (0th dot) 2-step (8th dot)	Horizontal print orientation: 10 x 8, 9 x 7 Vertical print orientation: 7 x N All print orientation: 7 x 8, 7 x 5, 5 x N, 5 x 5	
3	1-step (0th dot) 2-step (5th dot) 3-step (10th dot)	Horizontal print orientation: 7 x 5 Vertical print orientation: 5 x N All print orientation: 5 x 5	

### Number of scan dots15

Step	Distribution	Font sizes that can be registered	Image
1	1-step (0th dot)	Horizontal print orientation: 16 x 12 All print orientation: 12 x 10, 10 x 8, 9 x 9, 9 x 7, 7 x N, 7 x 8, 7 x 5, 5 x N, 5 x 5	
2	1-step (0th dot) 2-step (8th dot)	Horizontal print orientation: 9 x 7 Vertical print orientation: 7 x N, 7 x 8, 5 x N All print orientation: 7 x 5, 5 x 5	
3	1-step (0th dot) 2-step (5th dot) 3-step (10th dot)	Horizontal print orientation: 7 x 5 Vertical print orientation: 5 x N All print orientation: 5 x 5	

### Number of scan dots12

Step	Distribution	Font sizes that can be registered	Image
1	1-step (0th dot)	Horizontal print orientation: 16 x 12 All print orientation: 12 x 10, 10 x 8, 9 x 9, 9 x 7, 7 x N, 7 x 8, 7 x 5, 5 x N, 5 x 5	
2	1-step (0th dot) 2-step (6th dot)	Horizontal print orientation: 7 x 5 Vertical print orientation: 5 x N All print orientation: 5 x 5	

### Number of scan dots11

Step	Distribution	Font sizes that can be registered	Image
1	1-step (0th dot)	Horizontal print orientation: 12 x 10 All print orientation: 10 x 8, 9 x 9, 9 x 7, 7 x N, 7 x 8, 7 x 5, 5 x N, 5 x 5	
2	1-step (0th dot) 2-step (6th dot)	Horizontal print orientation: 7 x 5 Vertical print orientation: 5 x N All print orientation: 5 x 5	

### Number of scan dots 10

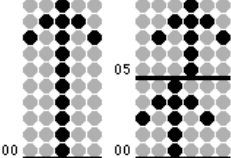
Step	Distribution	Font sizes that can be registered	Image
1	1-step (0th dot)	Horizontal print orientation: 12 x 10 All print orientation: 10 x 8, 9 x 9, 9 x 7, 7 x N, 7 x 8, 7 x 5, 5 x N, 5 x 5	
2	1-step (0th dot) 2-step (5th dot)	Horizontal print orientation: 7 x 5 Vertical print orientation: 5 x N All print orientation: 5 x 5	

### Number of scan dots 9,7, 5

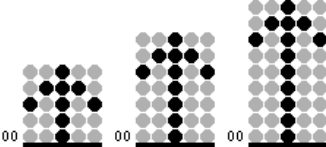
Dots	Distribution	Font sizes that can be registered	Image
5	1-step (0th dot)	Horizontal print orientation: 7 x 5 Vertical print orientation: 5 x N All print orientation: 5 x 5	
7	1-step (0th dot)	Horizontal print orientation: 9 x 7 Vertical print orientation: 7 x N, 7 x 8, 5 x N All print orientation: 7 x 5, 5 x 5	
9	1-step (0th dot)	Horizontal print orientation: 10 x 8 Vertical print orientation: 7 x N All print orientation: 9 x 9, 9 x 7, 7 x 8, 7 x 5, 5 x N, 5 x 5	

## ■ Samples of User-Specified Print Positions

Range of Possible Locations of the Lowest Dots in Each Font Dot

Vertical Dots	Character Orientation	24 x 24	24 x 18	16 x 16	16 x 12	12 x 10	10 x 8	9 x 9	9 x 7
26	Vertical	0-2	0-2	0-12	0-12	0-14	0-16	0-17	0-17
	Horizontal	0-2	0-8	0-12	0-14	0-16	0-18	0-17	0-19
24	Vertical	0	0	0-8	0-8	0-12	0-14	0-15	0-15
	Horizontal	0	6	0-8	0-12	0-14	0-16	0-15	0-17
22	Vertical	-	-	0-6	0-6	0-10	0-12	0-13	0-13
	Horizontal	-	0-4	0-6	0-10	0-12	0-14	0-13	0-15
20	Vertical	-	-	0-4	0-4	0-8	0-10	0-11	0-11
	Horizontal	-	0-2	0-4	0-8	0-10	0-12	0-11	0-13
16	Vertical	-	-	0	0	0-4	0-6	0-7	0-7
	Horizontal	-	-	0	0-4	0-6	0-8	0-7	0-9
15	Vertical	-	-	-	-	0-3	0-5	0-6	0-6
	Horizontal	-	-	-	0-3	0-5	0-7	0-6	0-8
12	Vertical	-	-	-	-	0	0-2	0-3	0-3
	Horizontal	-	-	-	0	0-2	0-4	0-3	0-5
11	Vertical	-	-	-	-	-	0-1	0-2	0-2
	Horizontal	-	-	-	-	0-1	0-3	0-2	0-4
10	Vertical	-	-	-	-	-	0	0-1	0-1
	Horizontal	-	-	-	-	0	0-2	0-1	0-3
9	Vertical	-	-	-	-	-	-	0	0
	Horizontal	-	-	-	-	-	0-1	0	0-2
7	Vertical	-	-	-	-	-	-	-	-
	Horizontal	-	-	-	-	-	-	-	0
5	Vertical	-	-	-	-	-	-	-	-
	Horizontal	-	-	-	-	-	-	-	-

Vertical Dots	Character Orientation	7 x N	7 x 8	7 x 5	5 x N	5 x 5
26	Vertical	0-19	0-19	0-19	0-21	0-21
	Horizontal	0-16	0-18	0-21	0-18	0-21
24	Vertical	0-17	0-17	0-17	0-19	0-19
	Horizontal	0-14	0-16	0-19	0-16	0-19
22	Vertical	0-15	0-15	0-15	0-17	0-17
	Horizontal	0-12	0-14	0-17	0-14	0-17
20	Vertical	0-13	0-13	0-13	0-15	0-15
	Horizontal	0-10	0-12	0-15	0-12	0-15
16	Vertical	0-9	0-9	0-9	0-11	0-11
	Horizontal	0-6	0-8	0-11	0-8	0-11
15	Vertical	0-8	0-8	0-8	0-10	0-10
	Horizontal	0-5	0-7	0-10	0-7	0-10
12	Vertical	0-5	0-5	0-5	0-7	0-7
	Horizontal	0-2	0-4	0-7	0-4	0-7
11	Vertical	0-4	0-4	0-4	0-6	0-6
	Horizontal	0-1	0-3	0-6	0-3	0-6
10	Vertical	0-3	0-3	0-3	0-5	0-5
	Horizontal	0	0-2	0-5	0-2	0-5
9	Vertical	0-2	0-2	0-2	0-4	0-4
	Horizontal	-	0-1	0-4	0-1	0-4
7	Vertical	0	0	0	0-2	0-2
	Horizontal	-	-	0-2	-	0-2
5	Vertical	-	-	-	0	0
	Horizontal	-	-	0	-	0

# 10 Appendix

## Dimensional Drawing

Unit

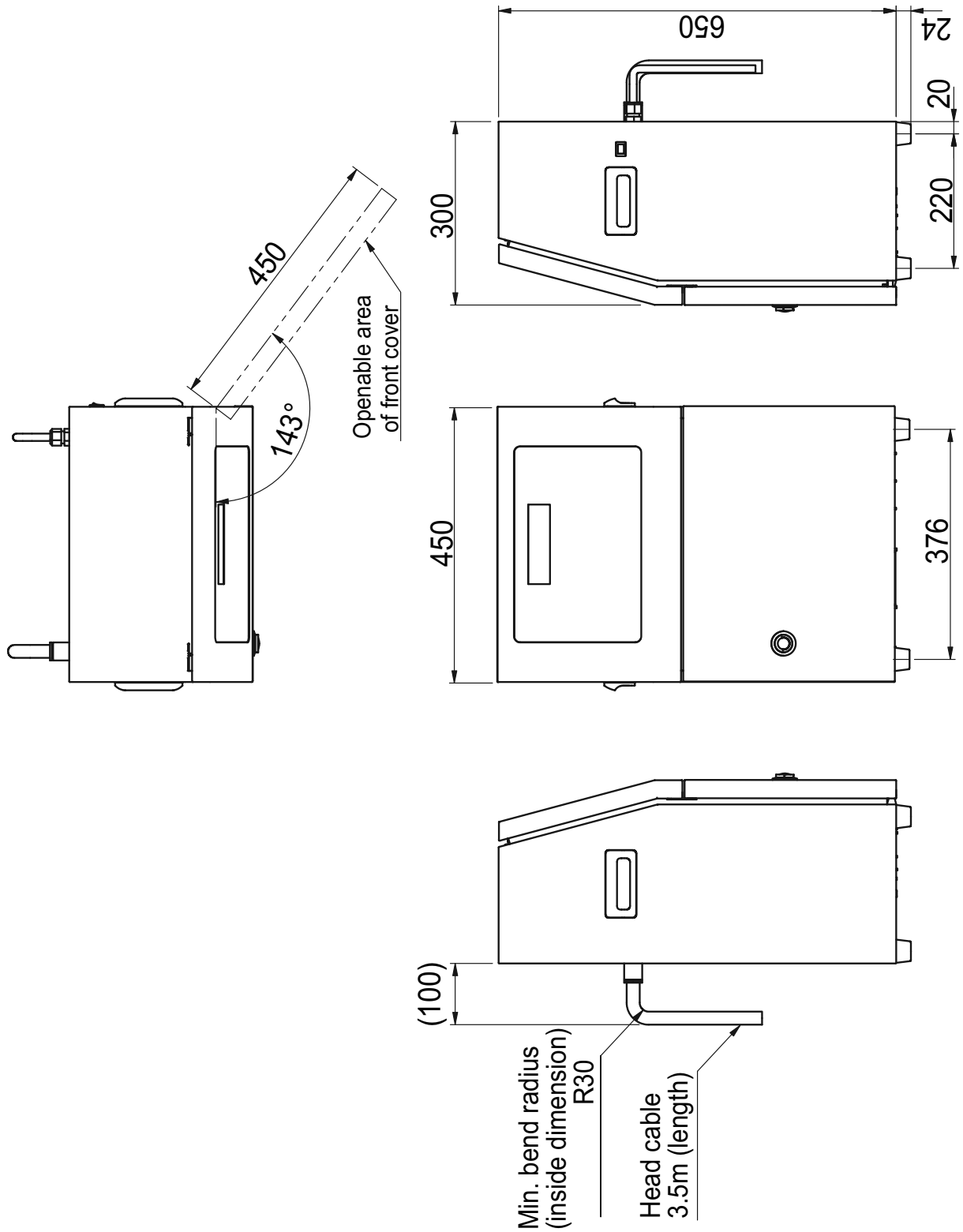

# Print Head

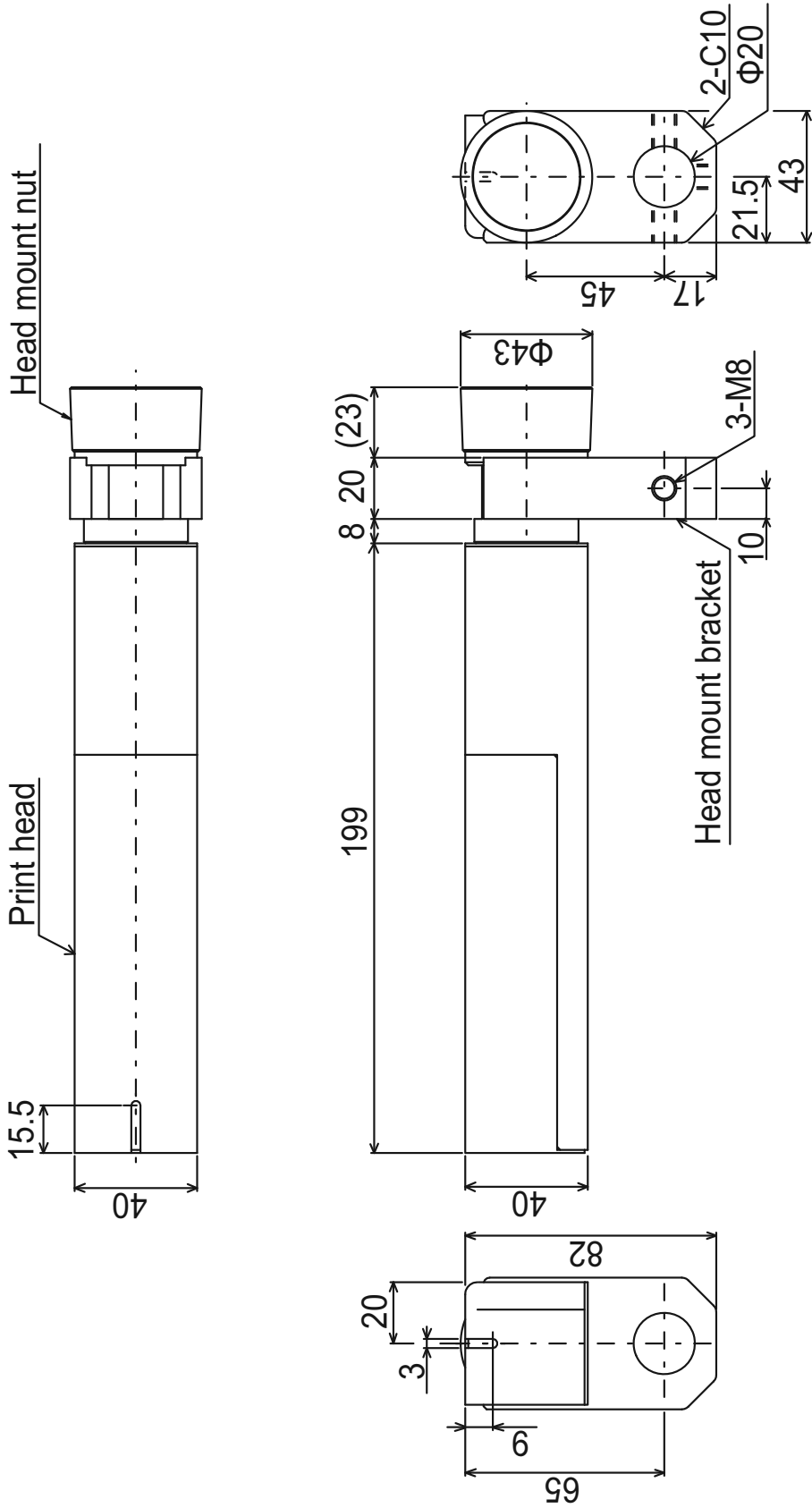

# Position of Label

Unit

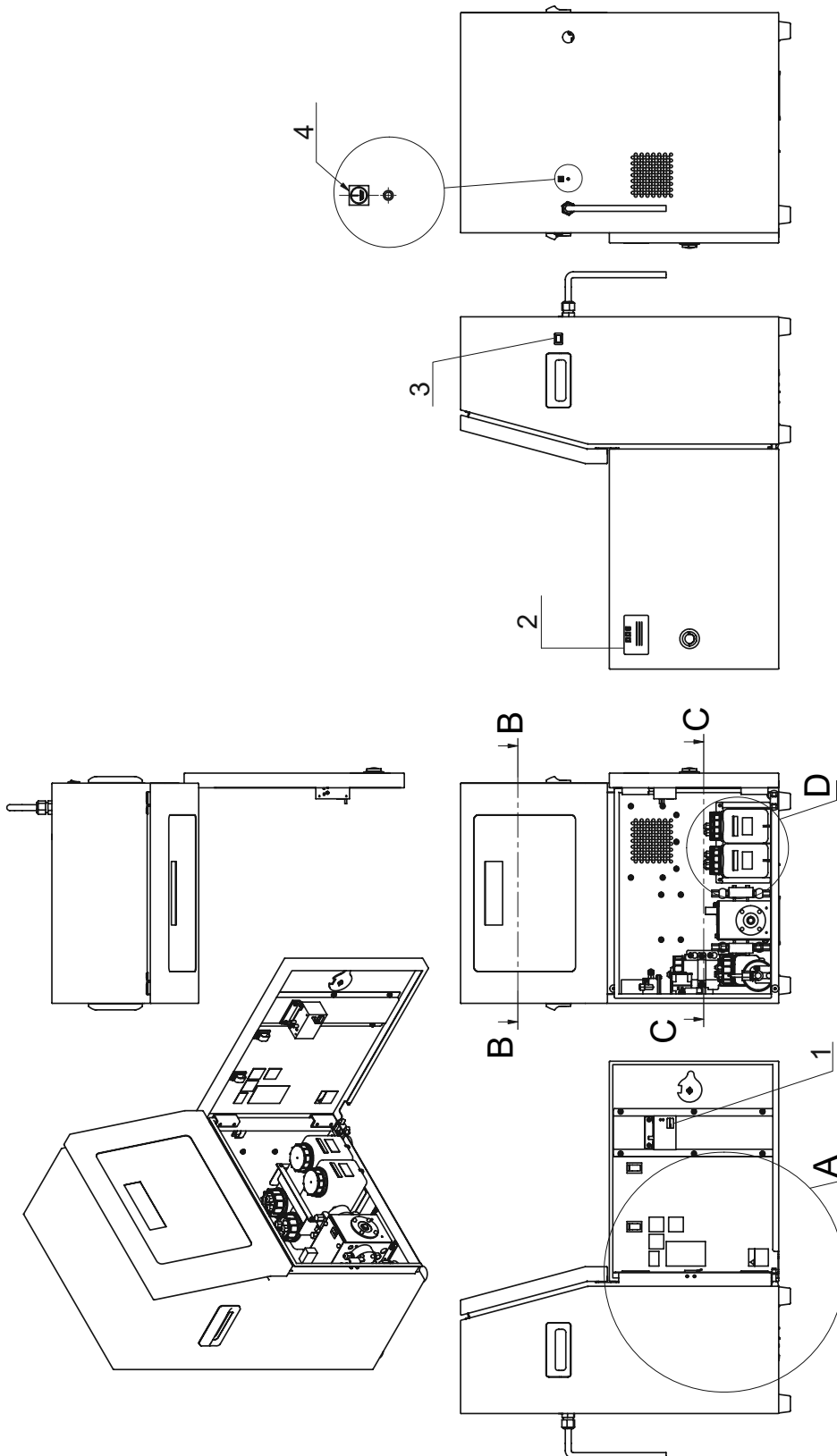

Detail A

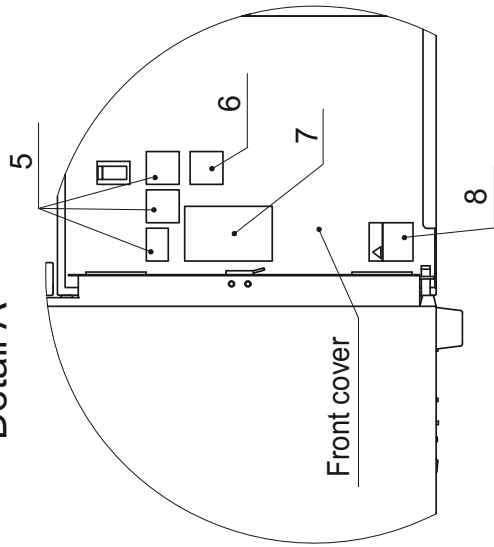

Detail D

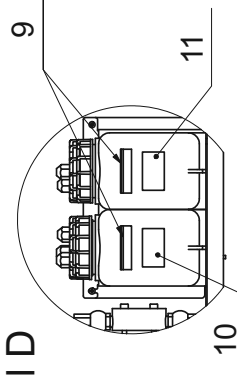

Cross section B-B

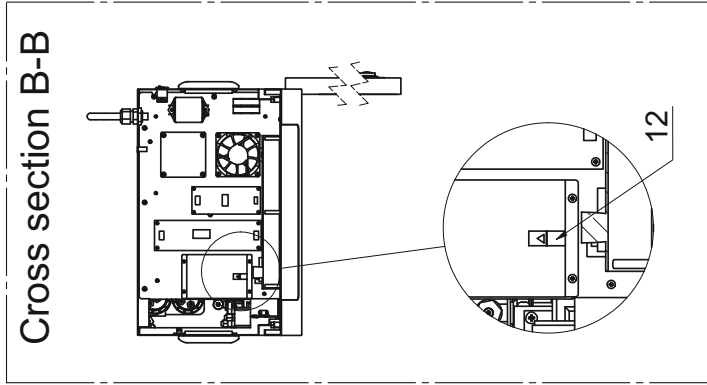

Cross section C-C

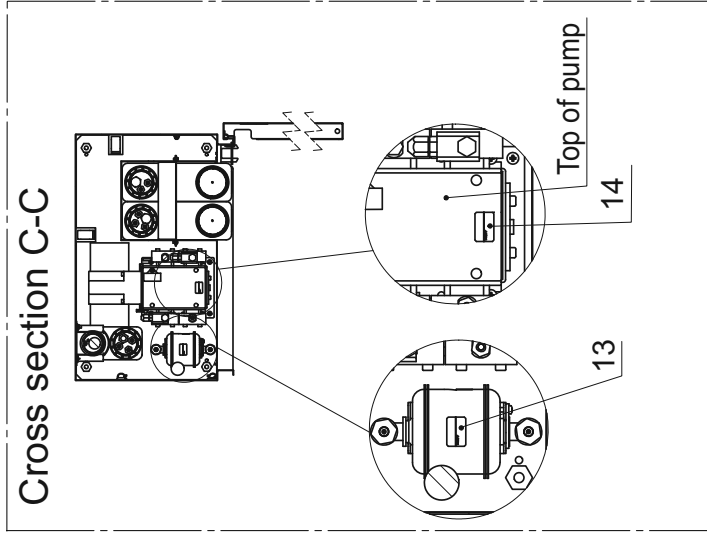

No.	Name
1	Exchange label for the air-pump
2	Signature plate
3	Power-switch label
4	Protective earth label
5	Version label for the unit
6	Version label for the print-head
7	Connector label
8	Cautions label for ignition
9	Max level label
10	Ink label
11	Solvent label
12	Cautions label for high voltage
13	Exchange label for the ink-filter
14	Exchange label for the pump

## Print Head

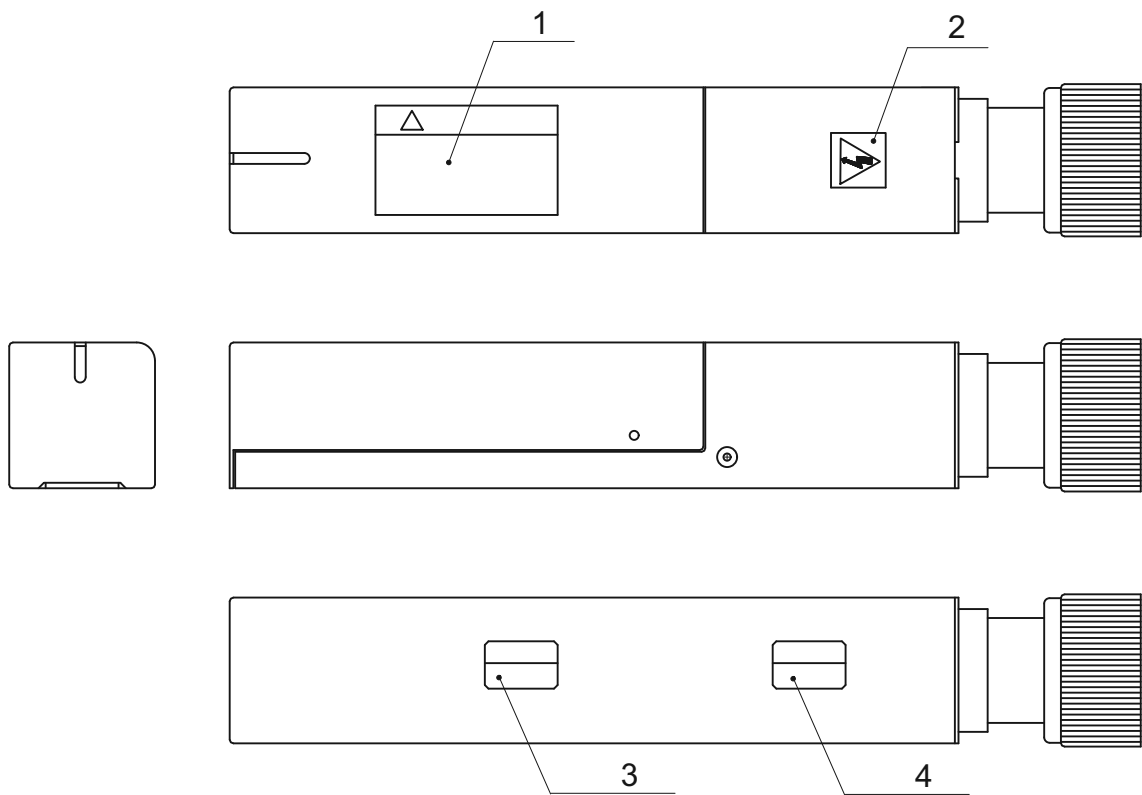

No.	Name
1	Cautions label for print-head
2	Cautions label for electric shock
3	Exchange label for the nozzle-gasket
4	Exchange label for the head-filter





466 Nunohiki, Wakayama City, Wakayama Prefecture, 641-0015, Japan  
<https://www.kishugiken.co.jp>

(Sep, 2021)  
TEC2702ZAN