

KGKJET CCS3100

Continuous ink jet printer for industrial use

Instruction manual

Introduction

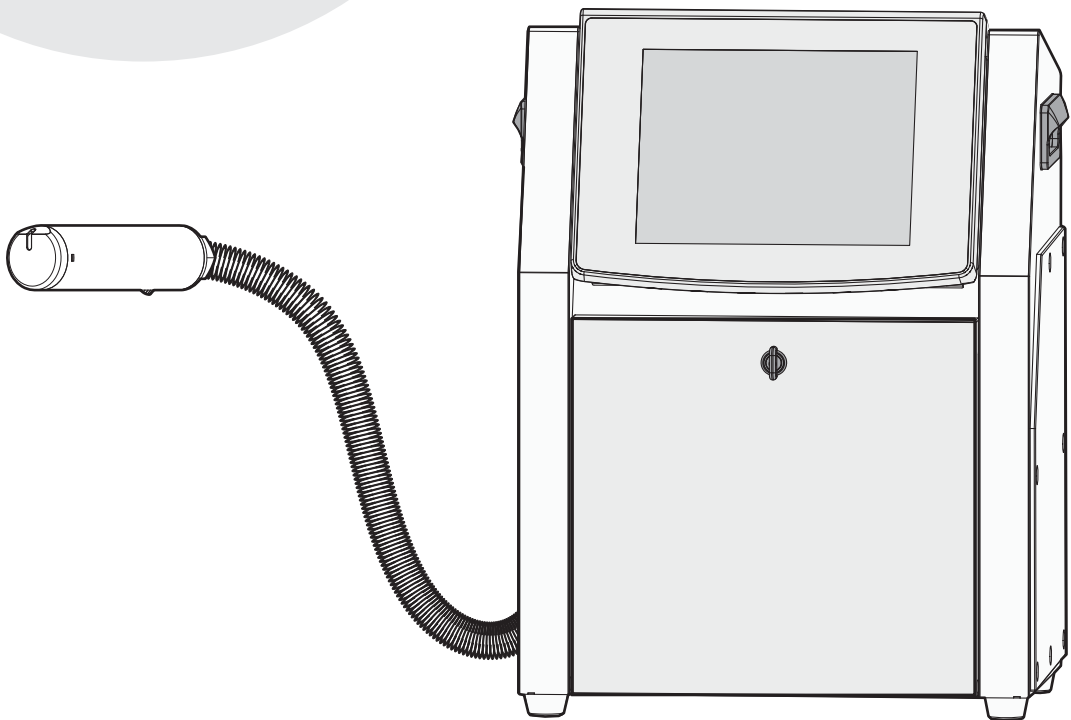

Thank you for purchasing our continuous ink jet printer for industrial use.

In order to properly use this unit, carefully read this instruction manual.

Please keep this instruction manual on hand so that you can consult it whenever any question and/or trouble arise while in use.

Introduction

Instruction manual - [Basic] (hereinafter called "this manual") describes the name of each part, installation, specifications, outline drawing, etc. of the ink jet printer. Thoroughly read this manual and properly use the printer.

In addition, read the "Instruction manual - [Operation/Maintenance]", "Instruction manual - [I/O]", and "Instruction manual - [Communication]" along with this manual.

About this manual

This manual is intended only for the KGK JET CCS3100 series.

This manual shall not be reproduced in part or in whole without our permission. Every effort has been made to prepare this manual. However, if you have any questions or find any errors in this manual, please contact us.

This manual is subject to change for improvements, etc. without notice.

Disclaimer

- We shall not be liable for any damage caused by fault, malfunction or defect of the CCS3100 series (hereinafter called "this product").
- We shall not be liable for any consequences if any parts, options or consumables other than our genuine parts are used, or any unauthorized modifications, etc. are made.

'QR Code' is registered trademark of DENSO WAVE INCORPORATED in Japan and other countries.

All other company and product names in this manual are trademarks or registered trademarks of their respective owners.





In this manual, ™ and © mark are not specified.

Safety precautions

Before use, thoroughly read the "Safety precautions" in this manual, and properly use this product to obtain its best performance.

This manual indicates the safety precautions as follows in order to prevent personal injury and/or property damage.

Description of the indication

 Danger	Indicates that improper handling in disregard of this indication may result in death or severe injury.
 Warning	Indicates that improper handling in disregard of this indication may result in personal injury or property damage.
 Caution	Indicates that improper handling in disregard of this indication may result in poor performance or breakdown of the product.
 Prohibit	This symbol represents "prohibition", indicating what shall not be done.
 Direction	This symbol represents "enforcement", indicating what shall be done.

Installation place

If the installation environment of the equipment is not appropriate, an unexpected accident or failure may occur. Carefully read the cautions in this section to install the equipment properly and safely.

Avoid installing the equipment in the following places. Otherwise, fire, an accident, a malfunction of the equipment, a printing defect, etc. may occur.

Danger



Place where solvent vapors are likely to remain, such as a closed space with poor ventilation, a stuffy space, and a narrow space

Solvent poisoning may result. In addition, fire may occur.



Place near a flame

Fire may occur. Never use a flame within 10 m from the equipment.



Avoid installing the equipment in a place with high temperature.

Avoid installing the equipment in a place exposed to direct sunlight or in a place with high temperature. Otherwise, fire may occur.



Dusty place

Avoid installing and using the equipment in a dusty place. Dust may cause a failure in the internal circuits, resulting in fire.

Danger



Prohibit

Avoid installing the equipment in a place subject to frequent vibration or in an unstable place.

Avoid installing the equipment in a place where vibration is directly transmitted to it or in an unstable place such as a wobbly place. Otherwise, the equipment may fall, causing personal injury.



Prohibit

Avoid plugging up the vent holes.

Avoid plugging up the vent holes of the equipment. Otherwise, the internal heat does not dissipate, and the resulting temperature rise may cause fire.



Prohibit

Noisy place

It may be impossible to hear an alarm buzzer sound, etc. Therefore, a response to an emergency situation may delay.



Prohibit

Place exposed to intense electromagnetic noise from other nearby equipment

Avoid welding work within 10 m from the equipment. Avoid tying the power cable and other power lines together in a bundle. Insulate the printhead to avoid direct contact with the conveyor, etc. Otherwise, a malfunction may occur.



Prohibit

Place in a corrosive gas atmosphere such as acid



Prohibit

Place where ambient temperature and relative humidity are outside the ranges of 0 to 40°C* and 10 to 85% RH (no-condensing) respectively

* 10 to 40°C depending on the type of ink



Direction

Be sure to establish a ground.

Establish a Class D ground.

Caution



Prohibit

Place exposed to intense electromagnetic noise from other nearby equipment

Avoid welding work within 10 m from the equipment. Otherwise, a malfunction may occur.



Direction

Insulation of the photocell sensor

If the photocell sensor is provided with a metal case, insulate it from the conveyor, etc. using plastic fittings.



Direction

Insulation of the printhead

Insulate the printhead to avoid direct contact with the conveyor, etc.

Caution

 **Prohibit** **Avoid tying power lines and other wires together in a bundle.**

 **Direction** **Air purging in the printhead with dry air**
Air purging in the printhead is recommended. Be sure to do that, especially in the case of use in humid surroundings or using pigment inks.
For specifications of the air, refer to "4-1 Product specifications" on page 52.

Power supply

Danger

 **Prohibit** **Banning the use of any power other than 100-240V, 50/60Hz**
Do not use any power other than 100-240V, 50/60Hz.
Failure to observe this may cause fire or electrical shock.

 **Prohibit** **Handling the power cables**
Do not damage, alter or heat the power cable. Do not put any heavy object on it.
Failure to observe this may damage the cable, resulting in a fire or electric shock.

 **Prohibit** The fuse is in the neutral, and the mains shall be disconnected to de-energize the phase conductors.
F1: 250V / 5A, F2: 250V / 5A

Caution



Prohibited connection/disconnection of the power cables while power is turned on

Do not connect/disconnect the power cables while power is turned on.

Failure to observe this may damage the equipment.

When you install or transport this product, open the cover, or connect with any equipment, be sure to connect or disconnect the cables according to the following procedures.

When connecting:

- 1** Turn OFF all equipment, including the externally connected sequencer, PC, etc.
- 2** Unplug this product.
- 3** Connect the cables to this product.
- 4** Plug in all the equipment.
- 5** Turn ON the power switches of all equipment.

When disconnecting:

- 1** Turn OFF all equipment, including externally connected sequencer, PC, etc.
- 2** Unplug this product.
- 3** Disconnect all cables that have been connected to this product.



This product is also designed for IT power distribution system with phase-to-phase voltage 230V.



This AC outlet shall be installed near the equipment and shall be easily accessible.

Checking

Danger



No one other than our service personnel may remove any covers unless otherwise instructed. There are many high-voltage portions inside the equipment, which are hazardous.



If the power cord, communication cable, or input/output cable is connected or disconnected while the power is on, the equipment may be damaged. When installing or moving this product, opening its cover, or connecting the equipment, follow the procedure described in this document.

In case of emergency

Danger

 **When the equipment emits smoke**
Direction If the equipment emits smoke or gives off an unusual odor, immediately turn off the power, and disconnect the power plug. Then, contact us. Further use in this condition may cause fire.

 **When foreign material enters the equipment**
Direction If foreign material (water, dust, etc.) enters the equipment, immediately turn off the power, and disconnect the power plug. Then, contact us. Further use in this condition may cause fire.

Precautions for handling

Danger

Use a container made of conductive material and connect it to ground, if, during test print or maintenance, print drops are collected in the container.

 **Direction** Print drops are electrically charged in a very small amount. If print drops accumulate, without connecting the container to ground, the amount of electric charge can become so big to cause fire.

In normal situations, however, the print substrate moves on the conveyor, hence there is no such a big amount of accumulation of electric charge to cause fire.

Caution

 **Prohibit** Do not apply acceleration of 0.1G or more to the head during operation. Doing so may cause stains inside the head and printing defects.

 **Direction** It may be impossible to achieve satisfactory printing and adhesion properties depending on the conditions of print targets (material, electrostatic charge, dew condensation, adhesion of oil, etc.) and transfer conditions (zigzag motion, transfer speed, etc.). Therefore, perform a printing test before using the equipment.

 **Direction** When this product is used in combination with other equipment, it may be impossible to achieve satisfactory functions and performance depending on the operating conditions, environment, etc. Therefore, give due consideration before use.

 **Direction** This equipment is not suitable for use in locations where children are likely to be present.

Precautions for using organic solvents, etc.

Precautions for handling

- Be sure to close the lid of any organic solvent containers when it is not in use.
- Avoid bringing more than the amounts of organic solvents, etc. needed directly for the day's work into the workplace.
- Always perform the work on the windward side where possible to avoid the inhalation of organic solvent vapor.
- Minimize skin contact with organic solvents, etc.

Effects of organic solvents on the human body (major symptoms)

- Headache
- Lassitude
- Dizziness
- Anemia
- Liver damage

First aid in case of poisoning

- Carry the victim of poisoning to a well-ventilated place, and immediately contact the health supervisor and other persons in charge of health management.
- Make the victim of poisoning lie on his or her back or side while keeping his or her head low, and keep his or her body warm.
- If the victim of poisoning is unconscious, remove foreign objects from his or her mouth.
- If the victim of poisoning has stopped breathing, immediately give artificial respiration.

Locations of warning seals

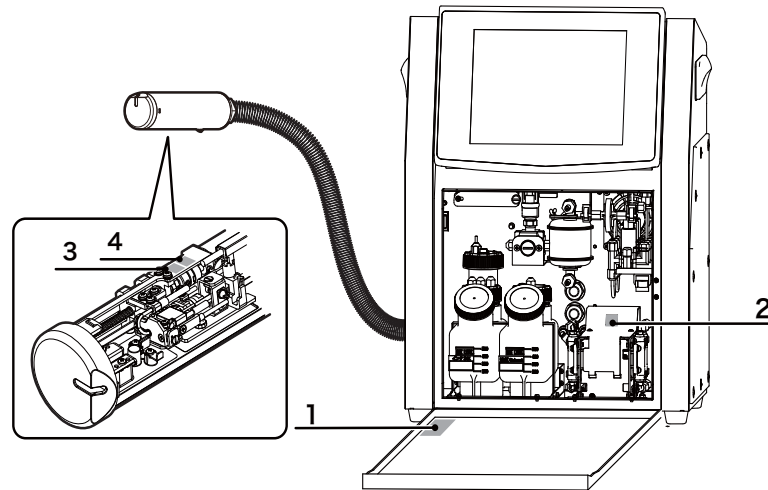

1



2



3



4



No.	Name	Description
1	Caution label about ignition	Be careful about the use of flames because a highly flammable solvent is used.
2	Caution label about rotation	Be careful not to get your fingers or hands caught in the rotating parts.
3	Caution/warning label about electric shocks	A high current is flowing at a high voltage while the product is operating.
4	Caution label about entanglement	Take care not to have your finger or hand in contact with the rotating part.

Contents

Introduction **2**

Safety precautions	3
Description of the indication	3
Installation place	3
Power supply	5
Checking	6
In case of emergency	7
Precautions for handling	7
Precautions for using organic solvents, etc.	8
Locations of warning seals	9

Contents **10**

Before use **12**

1-1 Features of the product	12
1-2 Product configuration and supplied items	15
Product configuration	15
Checking of supplied items	16
Options	19
1-3 Name of each section	20
Main unit (front side and right side)	20
Main unit (rear side and left side)	21
Main unit (inside)	22
Operation panel (front side and rear side)	23
Head (appearance and inside)	24
1-4 Installation and connection	25
Installation	25
Installation of the main unit	26
Installation of the printhead	28
Example of connection with external devices	29
1-5 From startup to termination	30
Operational flowchart	30
Turn on the power	31
Create or select message data	32

Set printing conditions _____	35
Switch the printhead to the stop mode _____	37
Turn off the power _____	38

2

Operation screen 40

2-1 Precautions for the touch panel _____	40
2-2 Description of the main screen, the menu screen, and the icon buttons.	40
Main screen _____	40
Menu screen _____	42
Icon buttons _____	43
2-3 Screen transition _____	46

3

Ink and solvent 48

3-1 Compatibility of ink, solvent, and cleaning solution	48
3-2 Consumption of ink and solvent _____	48
Ink consumption _____	48
Solvent consumption _____	48
3-3 Remaining amounts of ink and solvent _____	49
Viscosity measurement _____	50
Ink refilling operation in the equipment _____	51

4

Specifications 52

4-1 Product specifications _____	52
---	-----------

5

Dimensional outline drawing 62

5-1 Main unit _____	62
5-2 Printhead _____	63
5-3 Operation panel _____	64

1-1 Features of the product

This product is a continuous ink jet printer for industrial use, which can print high-quality characters with 36 vertical dots. Major features are as follows.

■ Nozzle capping system

The auto nozzle capping system seals the nozzle at the end of operation to prevent nozzle clogging arising from solidified ink at the nozzle section. It is not necessary to perform automatic cleaning with a solvent at the beginning or end of operation, and solvent consumption is thus reduced.

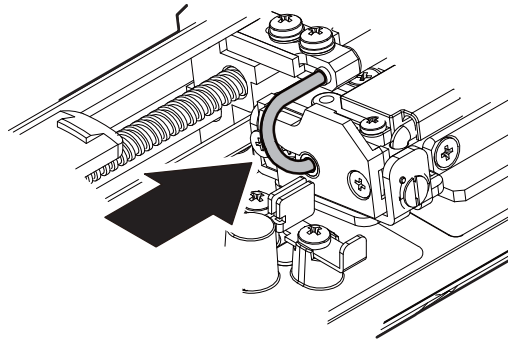

■ High-quality characters with 36 vertical dots

The maximum number of vertical dots is 36. The maximum number of font dots is 32 x 32. The maximum number of printing lines is 6. JIS 1st and 2nd standard Kanji characters, Katakana characters, Hiragana characters, alphabetical characters, numeric characters, symbols, and user-defined characters can also be printed.

In addition, this product is suitable for international operating environments because multiple languages are optionally available.



■ Ink is automatically circulated even when it is not running

This product has a timer mechanism that automatically circulates ink even when the equipment is not running. Therefore, there is no need to worry about nozzle clogging arising from dried ink even during a long vacation. In addition, the timer start/end time can be freely set.

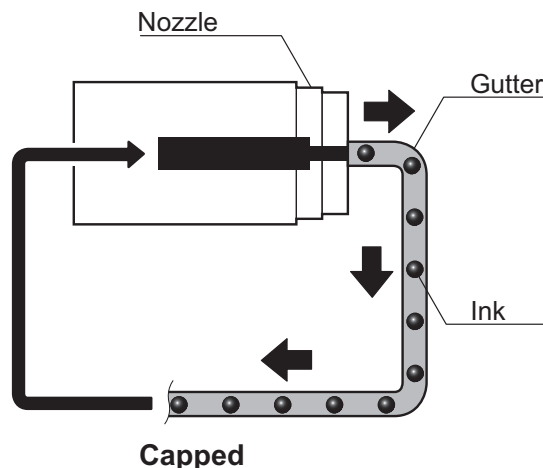

■ Design with consideration given to safety

The enclosure is equipped with a waterproof mechanism (equivalent to IP65) and a high-voltage safety circuit, and has been designed with consideration given to safety.

■ Improvement in the variety of connections with external devices

This product is newly equipped with a USB port and a LAN connector. It is possible to copy or back up data using USB media and to communicate through a network using a 10/100 Mbps Ethernet LAN port.

■ Improvement in the ease of operation and troubleshooting

The separate operation panel is connected to the main unit through a cable, and can be operated at a distance from the main unit. Therefore, every need can be met. For example, you can place it on a table, install it on a wall, or hold it with your hand when operating it.

The advanced settings of each function can be individually made, and the display items can be customized depending on the user's application.

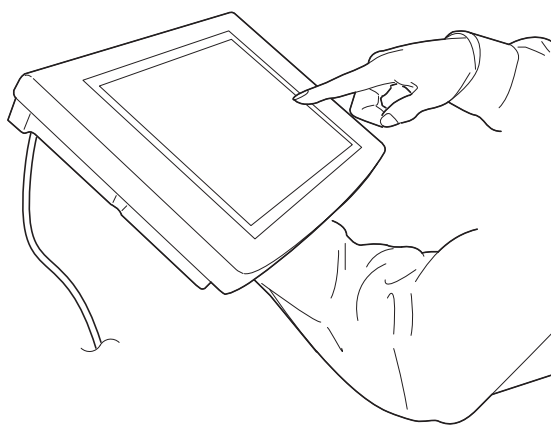

In addition to barcodes, 2D codes (QR codes and data matrices) can be printed.



The ease of troubleshooting has been improved. When an error occurs, the error can be resolved by following the procedure displayed on the screen.



■ **Slave control**

In some actions such as running control and selecting message, the operation you perform on a master unit can be done on slave ones simultaneously by connecting multiple units via LAN.

■ **The highly efficient printhead heater works as an air-conditioner to cope with the changing temperature**

The ink jetted from the nozzle will be heated to the fixed temperature by the heater. The ink viscosity will be kept within the designed range to print stably.

1-2 Product configuration and supplied items

Product configuration

This product is composed of the main unit, the printhead, and the operation panel. The printhead and the operation panel are individually connected to the main unit with cables, and cannot be disconnected.

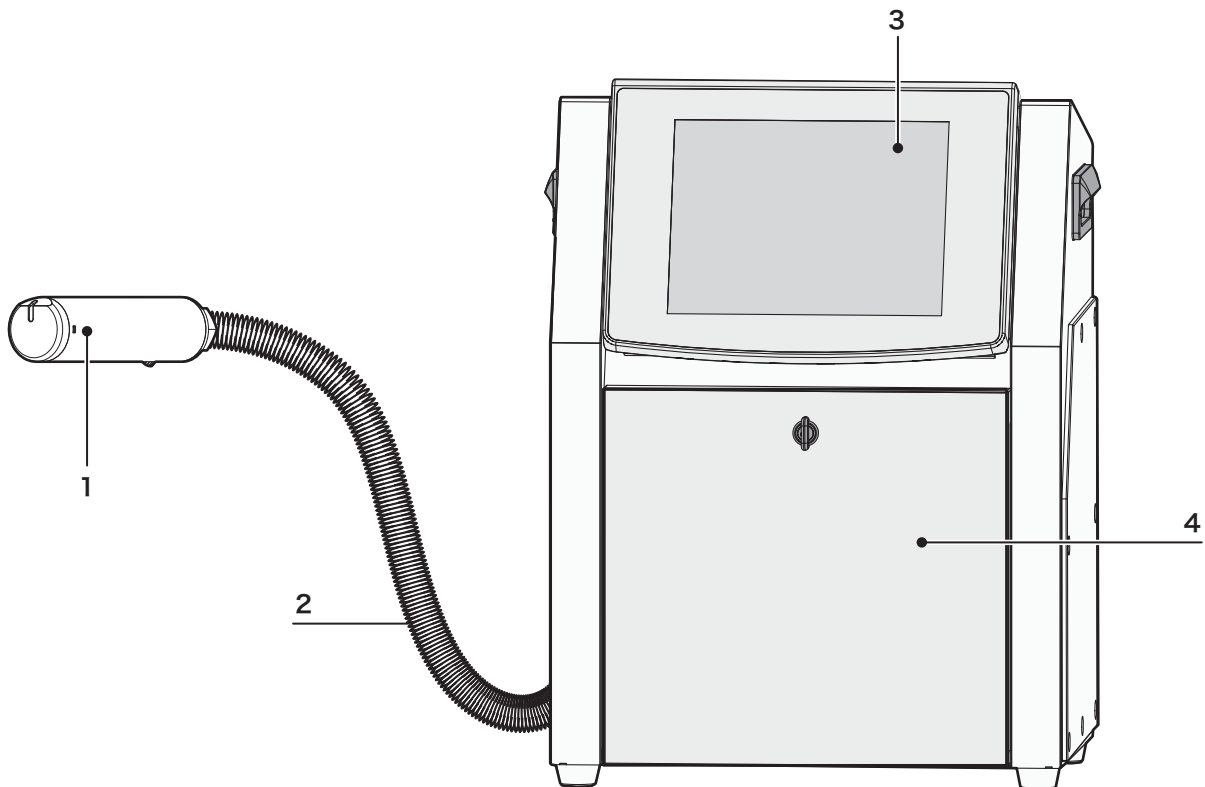

No.	Name	Description
1	Printhead	Printhead for printing characters on a workpiece (print target).
2	Head cable	Cable for connecting the printhead to the main unit. The length is 3.5 m. This cable cannot be disconnected from the main unit. (Minimum bending radius: 35 mm)
3	Operation panel	Panel operated by an operator. This panel can be taken off the main unit when it is used. The cable length is 3.5 m. This cable cannot be disconnected from the main unit.
4	Main unit	An ink circulating system for supplying ink to the printhead and an electronic circuit for driving and controlling the printhead are also contained.

Checking of supplied items

Supplied items including this product and its instruction manual.

■ CCS3100

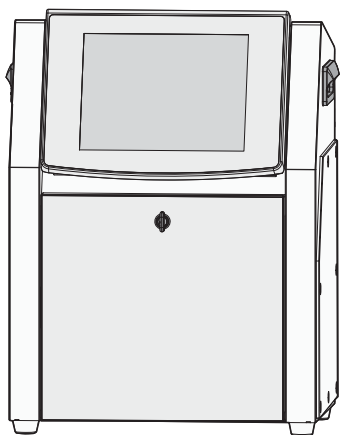

■ Instruction manual

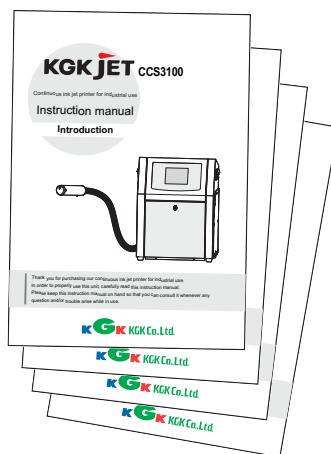

■ Set of maintenance tools

- Washing bottle

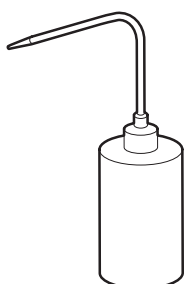

- Container

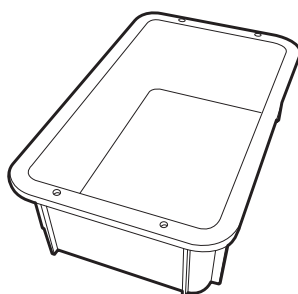

- Dryer

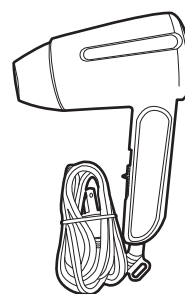

- Safety goggles

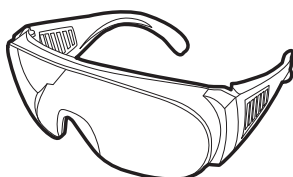

- Phillips screwdrivers (No.0, No.1, No.2)

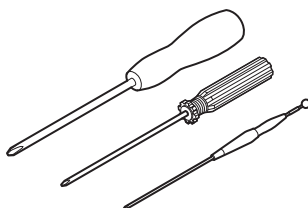

- Flat-blade screwdriver

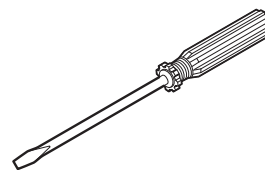

- Manual pump



- Set of wrenches



- Spanners (8mm, 11mm)

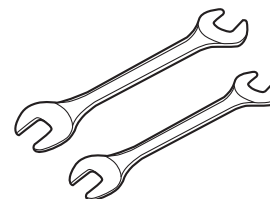

- Clearance gauge

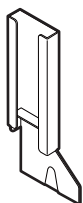

- Kaydry

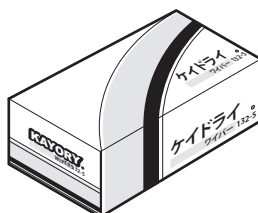

- Tweezers



- Stirring rod *

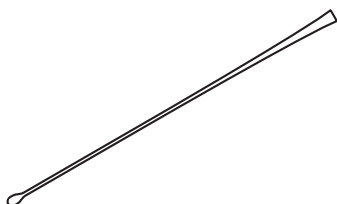

- Gun unit fixture

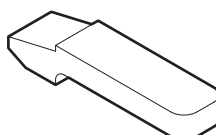

* Stirring rod is supplied item only for the pigment model with agitation mechanism.

■ Spare parts of replacement

- Diaphragm unit (without spacer), Diaphragm unit T1 type (with spacer), Diaphragm unit T2 type (with spacer), or Diaphragm set *

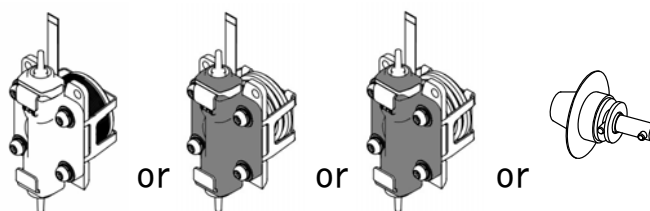

* Above is the spare parts of replacement only for using the specific dye ink or the pigment ink.

Name	Remarks	Quantity	
CCS3100	This product	1	
Instruction manual	This document	1	
Set of maintenance tools	Washing bottle	Put a cleaning solution into this bottle, and then use it.	1
	Container	For cleaning the printhead	1
	Dryer	For drying the printhead after cleaning it	1
	Safety goggles	-	1
	Phillips screwdrivers (No.0, No.1, No.2)	-	1 each
	Flat-blade screwdriver	-	1
	Manual pump	For drying the printhead after cleaning it	1
	Set of wrenches	-	1
	Spanners (8mm, 11mm)	-	1 each
	Clearance gauges	For adjusting the clearances of the gutter and the nozzle	1
	Kaydry	For cleaning and drying the printhead	1
	Tweezers	-	1
	Stirring rod	For stirring ink (only for the pigment machine with agitation mechanism)	1
Gun unit fixture	For fixing the gun unit	1	



Before use

Name	Remarks	Quantity
Spare parts of Diaphragm unit replacement or Diaphragm set	Replacement parts for the pump (only for using the specific dye ink or the pigment ink)	1

Options

The following options are not included with this product, but are useful in improving print quality, maintenance, etc.

Name	Description
Self-supporting stand	For the print direction, side-surface printing or top-surface printing can be selected. For the mounting method, a self-supporting type or a supported type can be selected.
Controller table	Table on which the controller is placed.
Photocell sensor	For the photocell sensor type, a transmission type or a diffuse reflection type can be selected. In addition, a conveyor-supported type or a head-supported type can be selected.
Encoder	Allows printing at a constant pitch even if the conveyor speed fluctuates.
Push-button printing switch	Allows manual print checks.
RS-232C cable	Needed for RS-232C communication
LAN cable	Needed for LAN communication
Signal lamp (flasher)	Indicates the operating condition of this product.

Recommended items

The following recommended items are not sold by us. However, they are useful in making emergency responses or improving the convenience of backups, etc.

Name	Description
UPS	Uninterruptible power supply unit, which is useful in the event of a power failure.
USB media (USB 2.0)	Needed to back up data, etc.
Nut driver (7 mm)	Useful for maintenance
Set of spanners	Useful for maintenance
Glass beaker (approximately 100 ml)	Used for maintenance
Ultrasonic bath	Used for cleaning when the nozzle is clogged.
Torque Driver (torque value 1.4 N·m)	Used when replacing the diaphragm set. It uses the case of the pigment ink and ink pump (PD series).

1-3 Name of each section

Main unit (front side and right side)

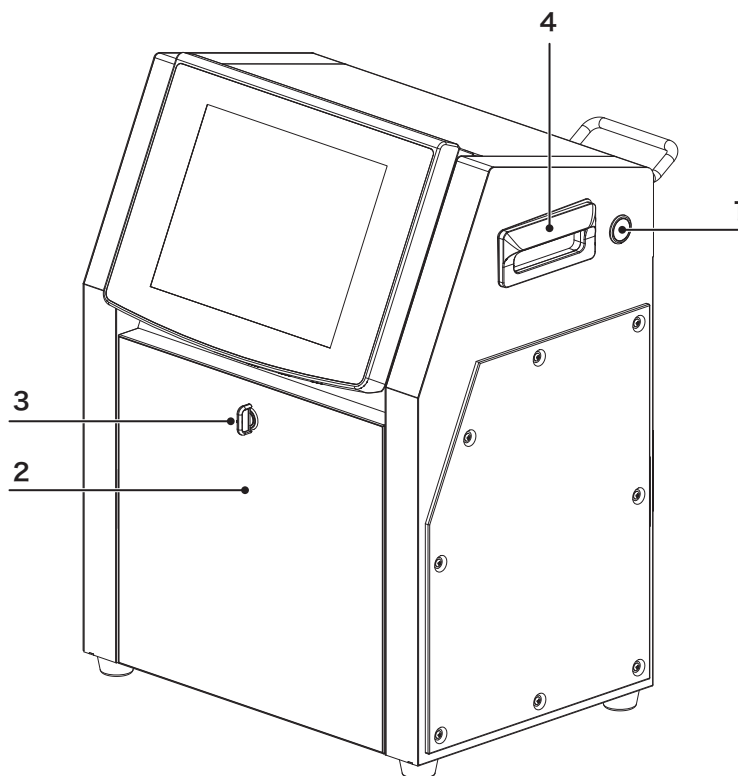

No.	Name	Description
1	① Main switch	Main power switch of this product. This is used to turn ON/OFF the main power.
2	Front door	Open this door at the time of ink refilling, maintenance, etc.
3	Knob	Turn this knob to open the front door.
4	Handle	Handle for transportation. This handle is attached on both the right and left sides.

Main unit (rear side and left side)

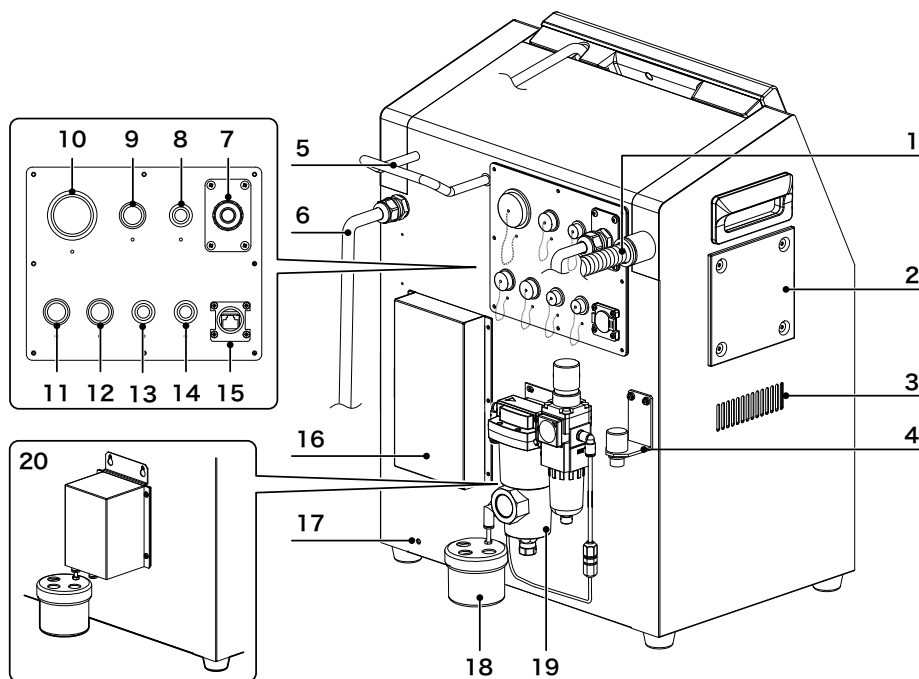

No.	Name	Description
1	Head cable	Cable for connecting the main unit to the printhead. The length is 3.5 m. This cable cannot be disconnected from the printhead. (Minimum bending radius: 35 mm)
2	Air filter	Prevents foreign bodies such as dust from entering the inside. Periodically perform maintenance.
3	Inlet	Air intake for ventilation and cooling of the inside of the main unit. Avoid plugging up the inlet.
4	Printhead fixing unit	Unit for fixing the printhead at the time of transportation
5	Cable holder	This is not a handle for transportation. Use the handles on the sides of the main unit.
6	Power cable	Power cable. This cable cannot be disconnected from the main unit.
7	Operation panel cable	Cable for connecting the main unit to the operation panel. The length is 3.5 m. This cable cannot be disconnected from the operation panel.
8	Photocell sensor connector	To use a photocell sensor, connect it to this connector.
9	RS-232C connector	To use a RS-232C cable, connect it to this connector.
10	I/O connector	To use an external device, connect it to this connector. When connecting the PLC, connect according to the instruction manual for PLC.
11	Signal lamp connector	To use a signal lamp, connect it to this connector.
12	Encoder connector	To use an encoder, connect it to this connector.
13	UPS connector	To use a UPS, connect it to this connector.
14	Purge pump connector	To use an air purge pump, connect it to this connector.
15	LAN connector	To use a LAN communication cable, connect it to this connector.
16	Outlet	Discharges heat from the inside of the main unit.
17	Frame ground	Connect a ground terminal to this part.
18	Condensate Tank Unit	Stores the waste liquid.
19	Air ventilation	Connect this part to a dry air source for printhead purging. Set the pressure setting to 0.1Mpa.
20	Driven pump for air purging	You can use this where there is no air supply facility. Not recommended for use in uncontrolled temperature or humidity environment with high temperature/humidity. Use "Air ventilation".

* These may not be attached depending on the model.

Main unit (inside)

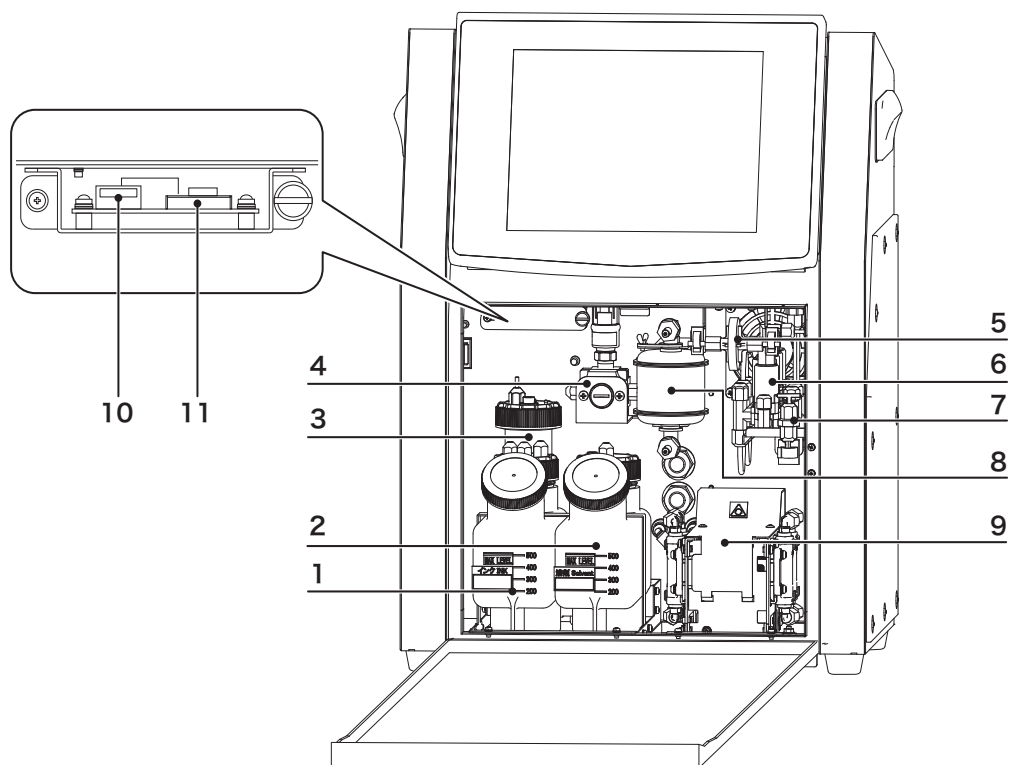



No.	Name	Description
1	Ink reservoir	Reservoir that holds ink
2	Solvent reservoir	Reservoir that holds an solvent
3	Main reservoir	Measures and adjusts the viscosity of ink
4	Regulator	Regulates the pressure of ink
5	Recovery filter	Filters out impurities from ink collected from the printhead.
6	Valve unit	Valve for controlling the flow of ink
7	Ink discharge	Plug for discharging ink
8	Ink filter	Filters out impurities from ink.
9	Ink pump	Pump for circulation and collection of ink
10	USB port	Insertion port for USB media
11	Backup battery	Battery for retaining system settings

Memo

In some types of ink, recovery filter is not equipped. For details, refer to the separate "Ink compatibility table".

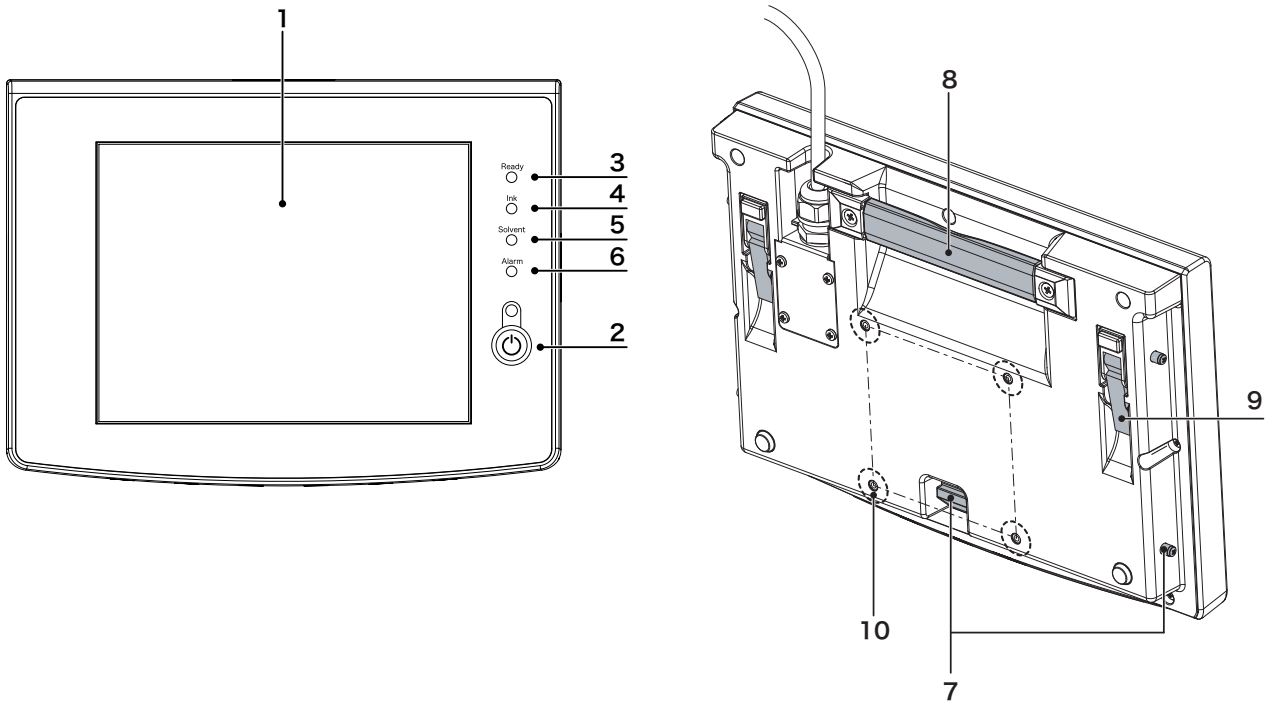
Operation panel (front side and rear side)



No.	Name	Description
1	Operation screen	Touch panel for selecting items, inputting values and characters, and displaying information
2	 Standby switch	This switch is used to boot and shutdown the system. It is lit in green when the system is in action, and it is lit in red during standby.
3	Ready lamp	This LED blinks during preparation, and it is lit in green when printing can be performed.
4	Ink lamp	This LED is lit in orange when the remaining amount of ink is low.
5	Solvent lamp	This LED is lit in orange when the remaining amount of solvent is low.
6	Alarm lamp	This LED is lit in red when an error occurs.
7	Detaching lever and guide pin	Lever for detaching the operation panel from the main unit Guide pin for reattaching it to the main unit
8	Hand grip	Use this grip when holding the panel with your hand to operate it.
9	Tilt stand	Lug for adjusting the angle of the panel when placing it on a table, etc. to operate it.
10	Threaded holes for installation (VESA standard)	100 mm x 100 mm. Use these holes when installing the panel on a wall, etc. (M4 x 4. The thread length should be "5 mm" + "the wall thickness.")

Head (appearance and inside)

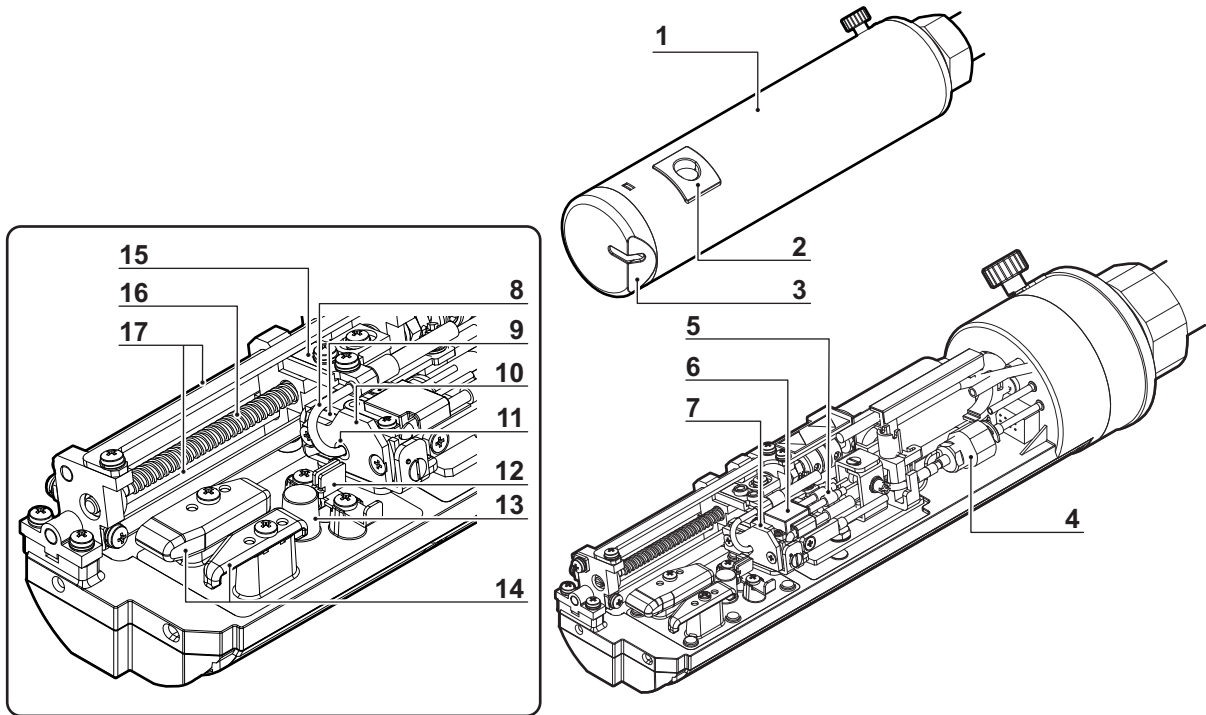

No.	Name	Description
1	Printhead cover	Upper cover of the printhead
2	Lens	Can observe ink droplet condition.
3	Head cover tip cap	When the head cover will not open due to the solidified ink, you can take this out for cleaning with the solvent. When attach the cap into the head cover, note the orientation of the cap. If attach the cap in the opposite orientation, can not mount the head cover correctly.
4	Head filter	Filters out impurities from ink.
5	Piezo	-
6	Heater	Heats up to a designed gun temperature.
7	Gun	-
8	Gutter	Collects ink.
9	Nozzle	Ejects pressurized ink.
10	Nozzle plate	Fixes the nozzle packing for nozzle capping.
11	Nozzle ejection port	Ejects pressurized ink.
12	Charge electrode	Charges ink droplets at a voltage depending on the amount of deflection.
13	Detection electrode	Detects charged ink droplets.
14	Deflection electrode	Applies a high voltage to deflect ink droplets.
15	Slide unit	-
16	Slide screw	-
17	Slide shaft	-

1-4 Installation and connection

Installation

■ Power and environment

Power supply	Rated power supply voltage	90 to 265 VAC, 47 to 63 Hz	
	Power consumption	80 W	
	Grounding	Class D ground	
Operating environment	Ambient operating temperature	0 to 40 [°C]	
	Ambient operating humidity	10 to 85 [%] (non-condensing)	
	Operating environment	Main unit	- Flat place - Place without high heat sources - Place that is not subject to rapid temperature changes - Place that is not subject to vibrations - Place that is not exposed to dust or oil - Well-ventilated place
		Printhead	- Place without high heat sources - Place that is not subject to rapid temperature changes - Place that is not subject to vibrations - Place that is not exposed to dust or oil

Memo

- The AC outlet shall be installed near the equipment and shall be easily accessible.
 - This product is also designed for IT power distribution system with phase-to-phase voltage 230V.
 - Ambient operating temperature varies depending on ink type. For details, refer to the separate "Ink compatibility table".
-

Installation of the main unit

Install the main unit according to the operating environment.

■ Clearances for installation

When installing the main unit, leave a clearance in each direction.

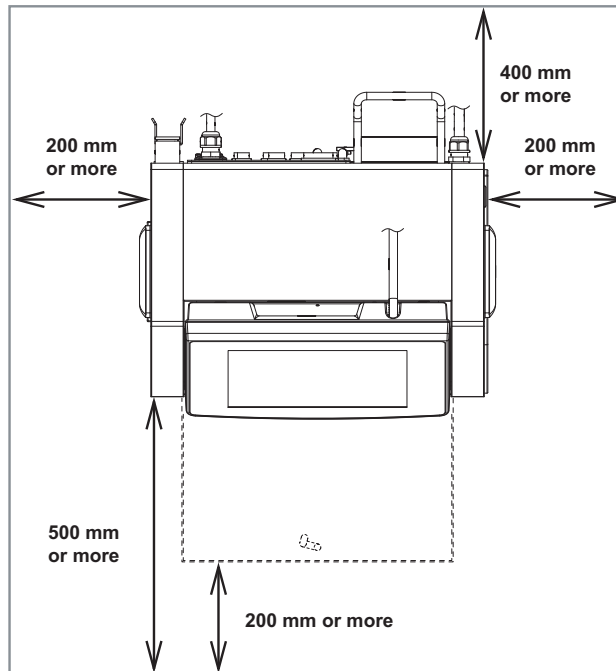

■ Detaching and reattaching the operation panel

To detach the operation panel from the main unit, pull up the lever on the back of the panel to detach it in the direction pointed by the (white) arrow.

To reattach the operation panel to the main unit, fit the four guide pins of the operation panel into the main unit and reattach it in the direction pointed by the (gray) arrow. When the lever is locked, reattachment is completed.

Detachment

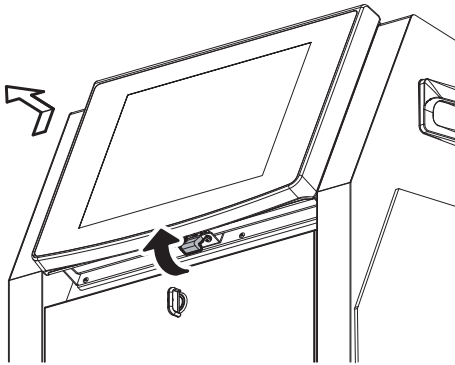

Reattachment

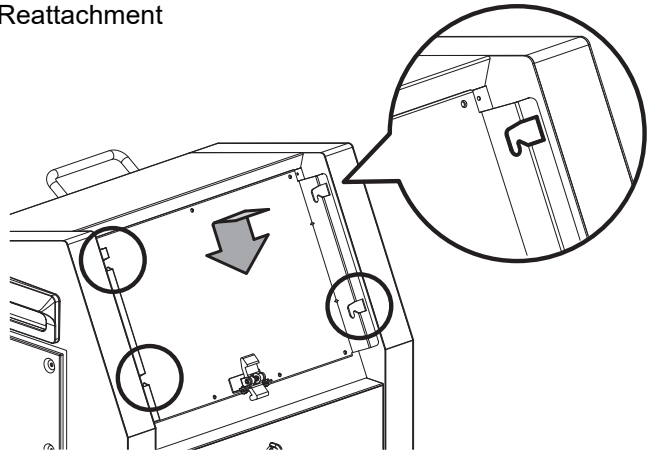

Caution

If you accidentally drop the operation panel and a problem such as screen flickering occurs, it is not covered by the warranty.

Memo

For the adjustment of the touch panel, contact us.

Installation of the printhead

Install the main unit according to the operating environment.

Memo

If you want to move the printhead to perform printing, contact us.

■ Installation direction

The printhead can be installed in any direction.

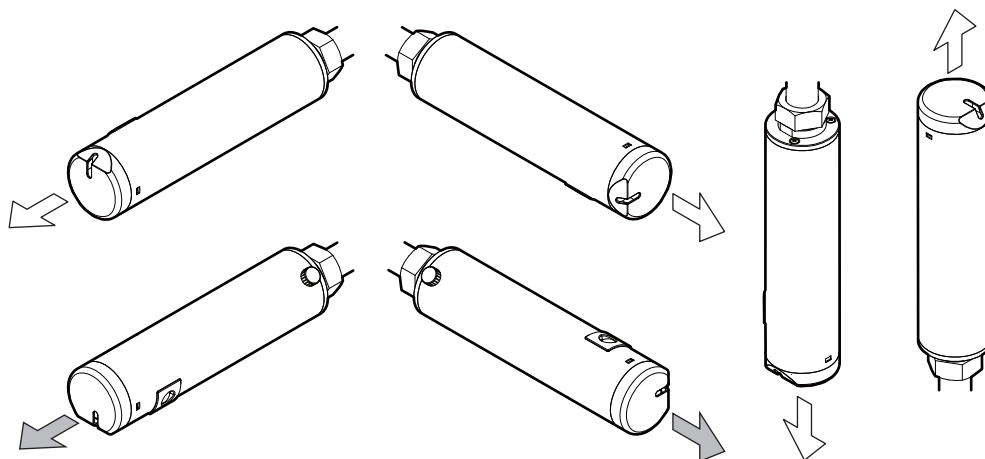

■ Positional relationship with the main unit

Install the printhead within 1.5 m above and 1.0 m below the bottom of the main unit.

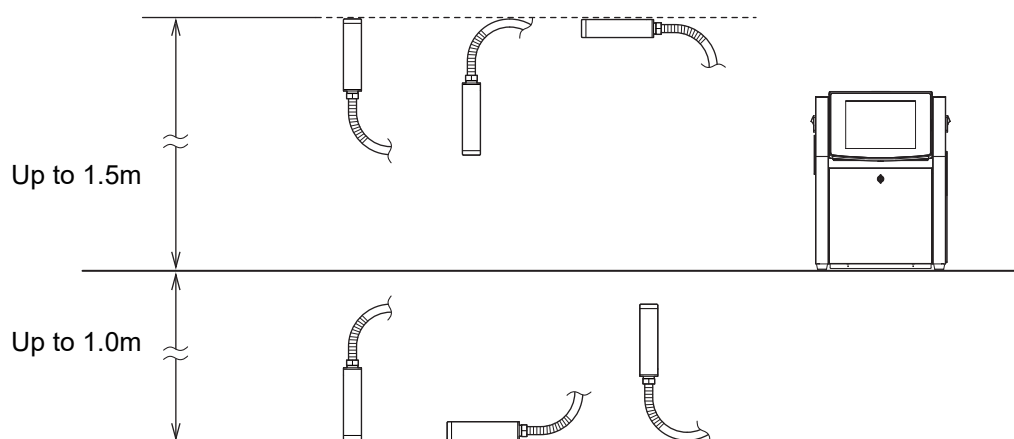

■ Distance from a workpiece

A recommended distance between the printhead and a workpiece is as follows.

Nozzle bore	Recommended distance from a workpiece
40 μm	5 mm
50 μm	15 mm
60 μm	25 mm
75 μm	50 mm

Example of connection with external devices

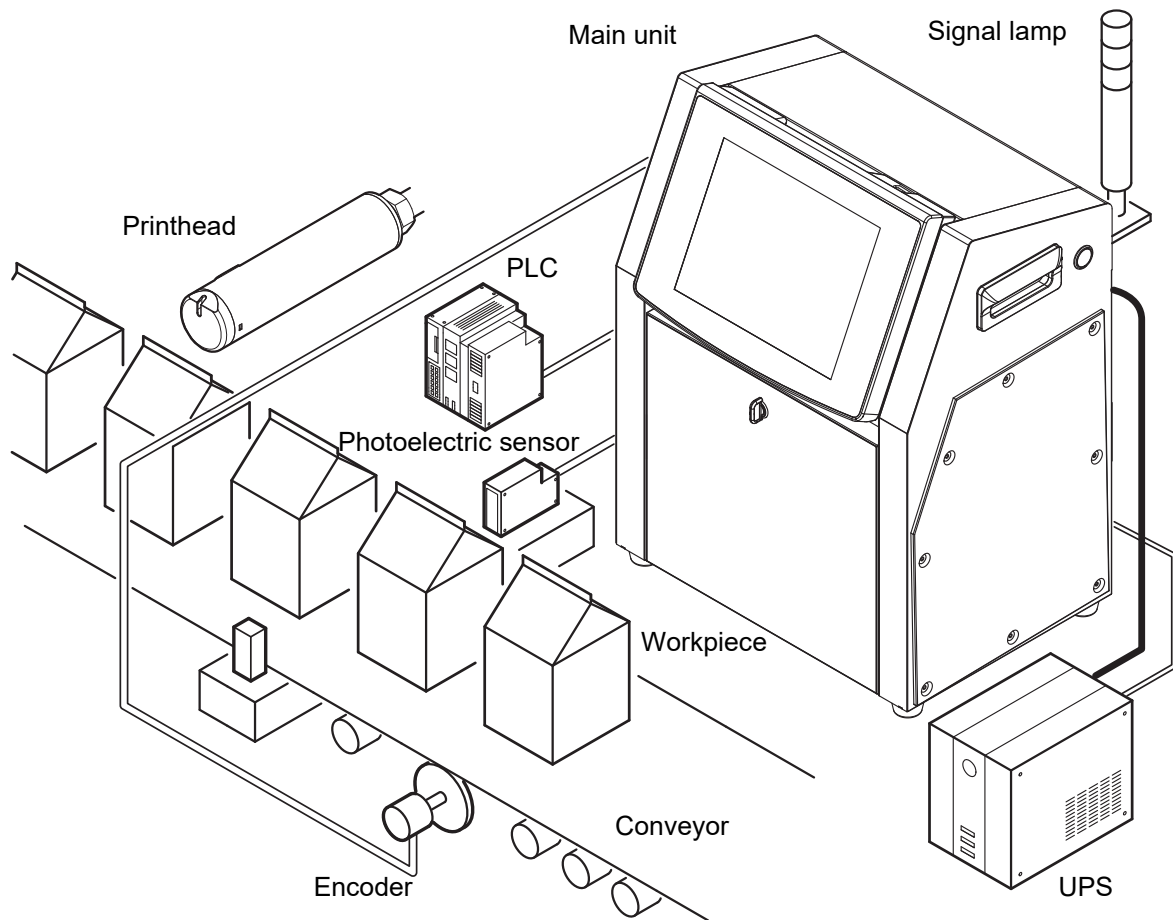

This product receives input signals from an encoder, a photocell sensor, etc. to make settings for printing. It receives an input signal as a trigger from a photocell sensor, calculates the timing of printing, and prints characters on a workpiece.

If the line speed is not constant, it receives a signal from an encoder to adjust the timing of printing.

Based on input/output signals from a PC and a PLC, the whole line can be systematized.

In addition, when a signal lamp is connected, an error can be visually output.

For the connection and setting of these devices, refer to the separate instruction manuals: "I/O," "Communication," and "Operation/Maintenance."

1-5 From startup to termination

This section shows a sequence of operations from turning on the power to turning off the power.

Operational flowchart

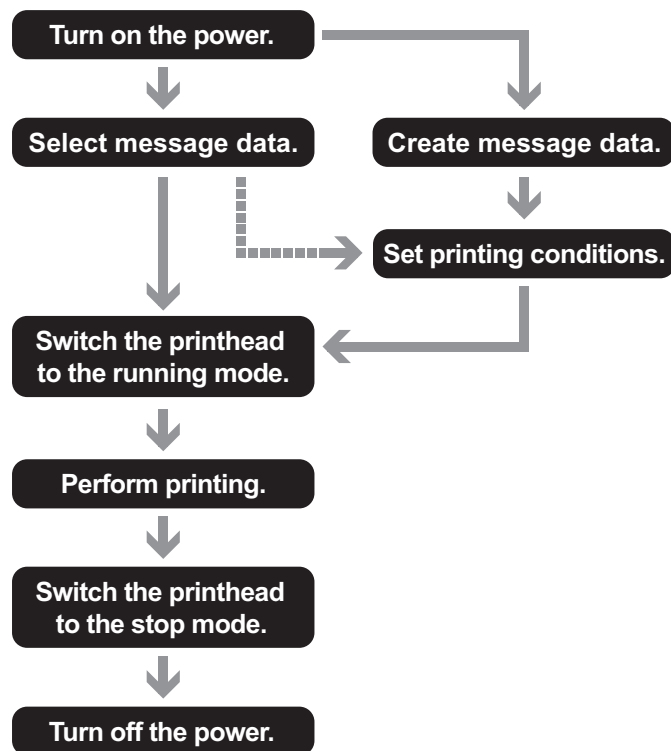

Turn on the power

- 1** Check that various kinds of cables including the photocell sensor signal cable are correctly connected.
- 2** Turn on the main switch on the right side of the main unit.

Memo

- The main switch also acts as an emergency stop switch.
- Basically, keep the main switch on. If it is turned off, automatic startup using the timer is disabled. For example, when the installation place is changed, or when instructions are provided during maintenance, turn off the main switch.

- 3** Turn ON the standby switch of the operation panel.

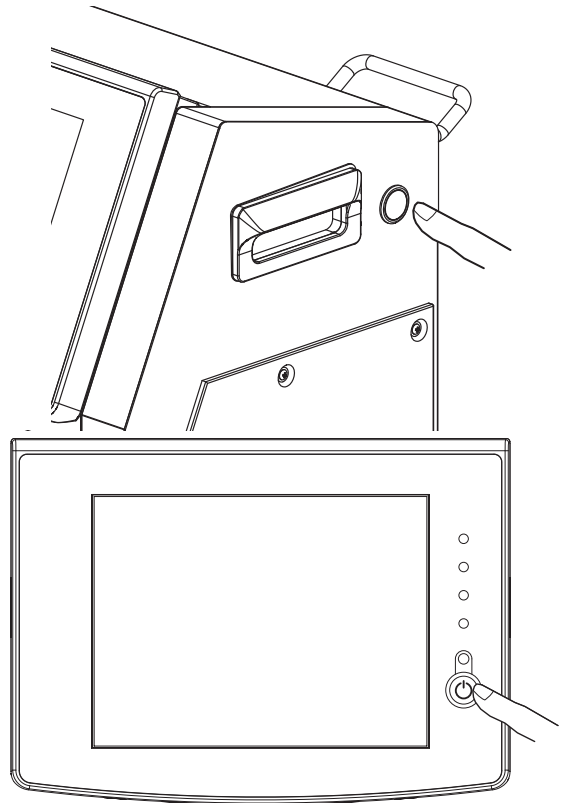

First, the Boot loader screen appears.

Memo

If the display has accidentally switched to the Boot loader screen, press the [Quit] button once and press the [YES] button three times.

Next, the Bleed screen appears.

After a while, the main screen appears.

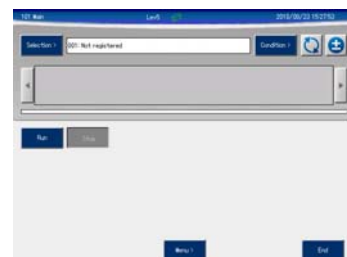





Create or select message data

- 1 In this section, create characters "ABCDE" as a sample.

Press the [Select] button on the main screen.

- 2 Select a message data field to be created (No. 001 in this example), and press the  button.

To select the message number, press the message number directly, or move the cursor using the  button or the  button or the  button or the  buttons.

Alternatively, press the [Search] button, and then select by the message number or the message comment.

- 3 When "Set?" appears, press the [Yes] button to enter.

- 4 A dialog box appears stating "It is not registered. Create?". Then, press the "Yes" button to enter.

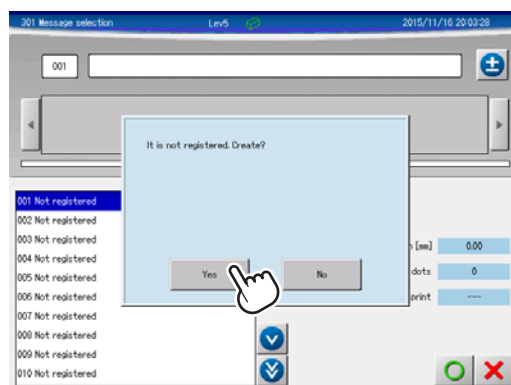
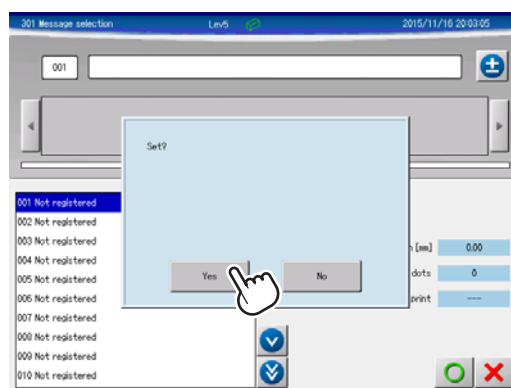
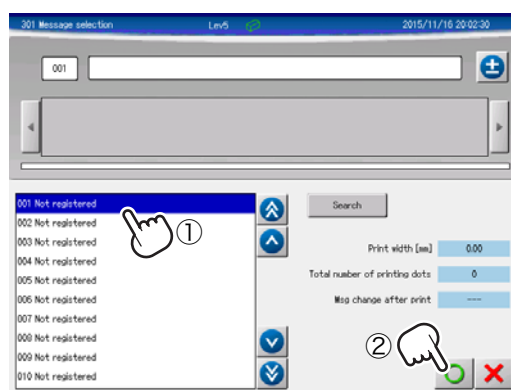
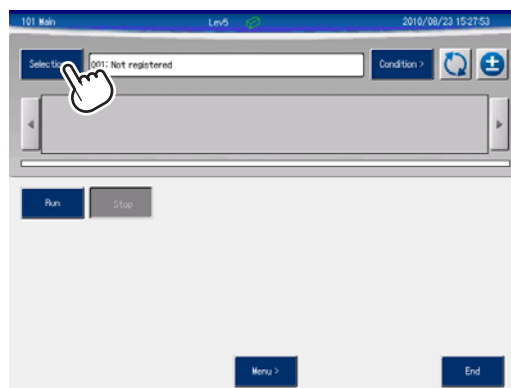

- 5** Create or select a text module to be placed in message data.

Press the **A** button, and press the preview area.

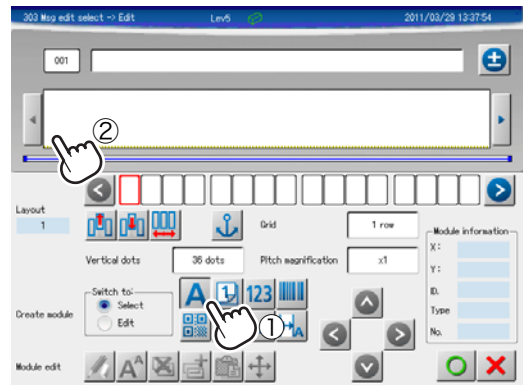

- 6** Select a module data field to be created (No. 001 in this example), and press the **A** button.

Directly press a displayed module data field or move the cursor to module data to be selected using the **↓** **↑** buttons or the **↓** **↑** **↓** **↑** buttons.

Alternatively, press the [No.Select] button, and then enter using a ten-key pad.

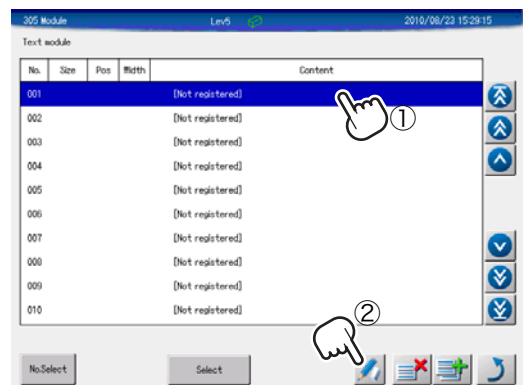

- 7** Press the text module entry field, and edit characters.

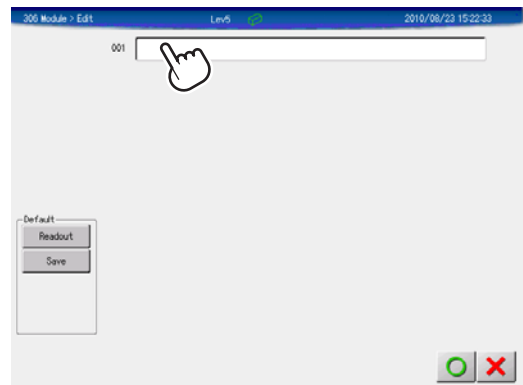

- 8** Press "A," "B," "C," "D," and "E." Then, press the **Enter** button to enter.

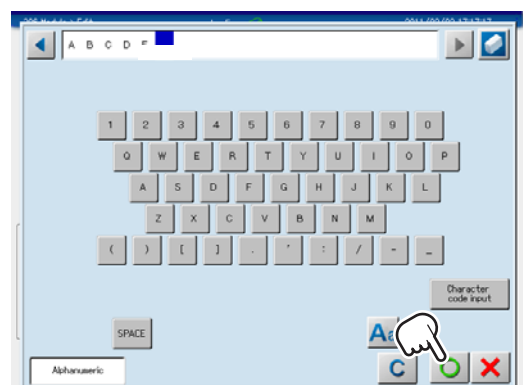

Before use

- 9** When "Set?" appears after pressing the  button, press the [Yes] button to enter.

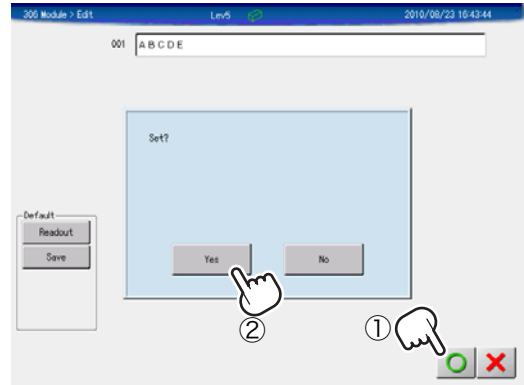

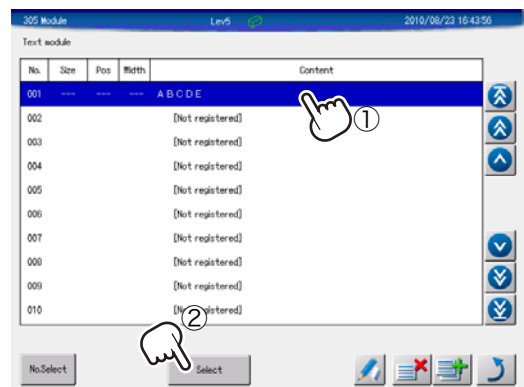

- 10** Select the created text module, and press the [Select] button.

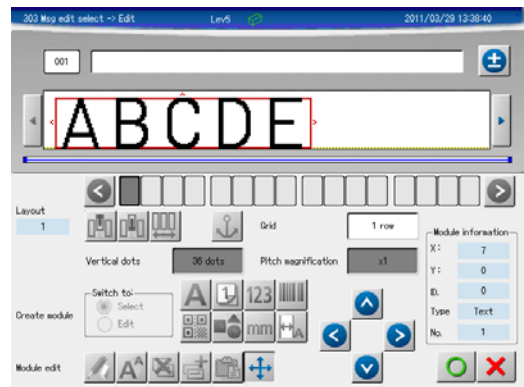

- 11** The text module is displayed in the preview area of the "Msg edit select" screen.



- 12** When "Set?" appears after pressing the  button, press the [Yes] button to enter.

Press the  button, and press the [Main] button on the menu screen.

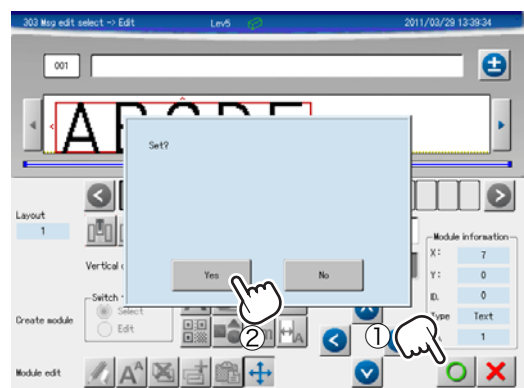

- 13** The data "ABCDE," which has been created this time, is displayed in the preview area of the main screen.

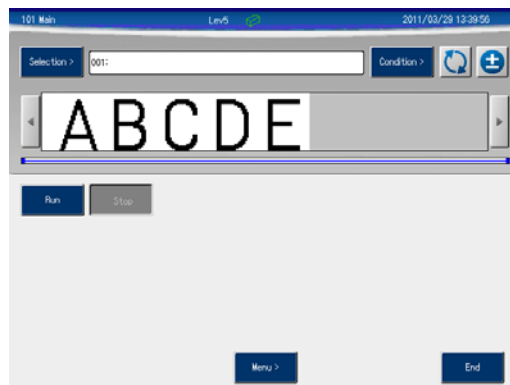

Set printing conditions

- 1** Press the [Condition] button on the main screen or the menu screen.

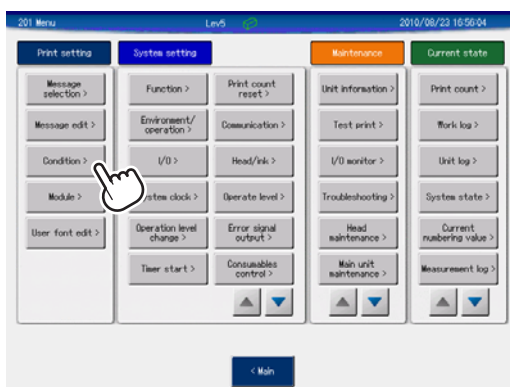

- 2** Press the [Condition] tab.

Memo

The number of tabs displayed and the number of items displayed in the tabs depend on the setting of each item in [Menu]-[Function]-[Printing].

Display various setting tabs in [Menu]-[Function]-[Printing].

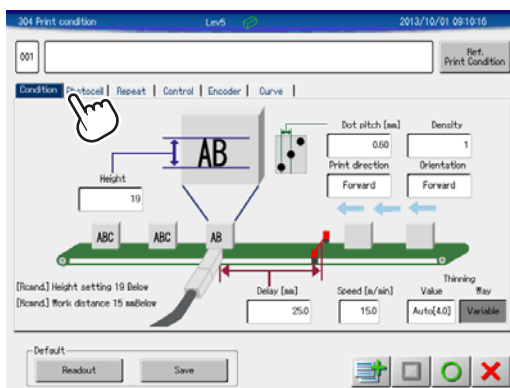

- 3** Press the setting field of each item, and make the settings.

Memo

For details of printing conditions, refer to "1-4. Setting of the printing conditions, Setting of the printing conditions" in the separate Instruction manual: "Operation/Maintenance".

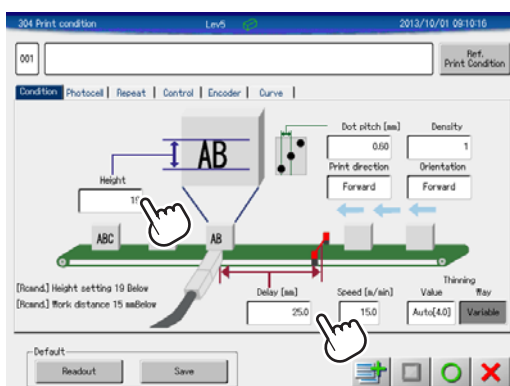

- 4** When "Set?" appears after pressing the  button, press the [Yes] button to enter.

Pressing the [Readout] button returns the entered conditions to the content specified as default.
 Pressing the [Save] button sets the entered conditions as default.
 To change the message data to set the printing conditions, press the [No.Select] button.

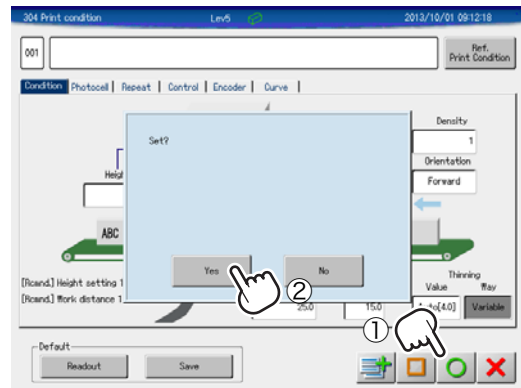

Switch the printhead to the running mode

- 1** Check that the "Head heating complete" icon is displayed and the head heater temperature exceeded the "Operational temperature".

Memo

If you run the printhead when the "Head heating complete" icon is not displayed, the printhead will not be ready for printing.

It may take a long time until the heating is completed, depending on the ambient temperature.

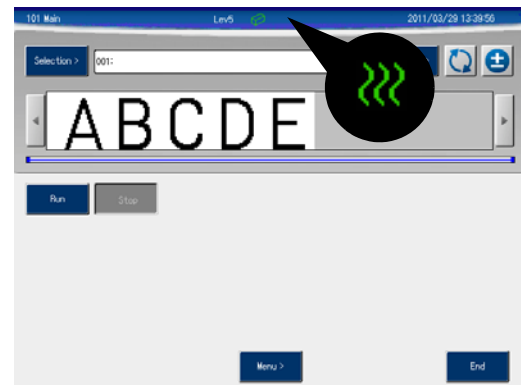

- 2** When the [Run] button is pressed on the main screen, a dialog box appears stating "Set to the run mode?". Then, press the "Yes" button.

Memo

When the printhead is switched to the running mode, the gutter in the printhead moves, and the printhead is ready to receive a print command (photocell sensor, external I/O input).



- 3** When preparation for printing is completed, the Ready lamp lights up



Perform printing

- 1 When a workpiece flows and a print command is received, the specified printing content is printed.

Memo

Test printing can be performed by pressing the [Test print] button on the menu screen.

Switch the printhead to the stop mode

- 1 When you press the [Stop] button, a dialog box appears stating "Stop?" Then, press the "Yes" button.

The gutter moves, and the nozzle is capped. Then, the Ready lamp goes out.

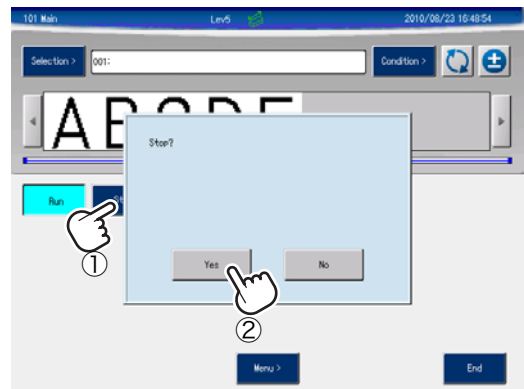

Turn off the power

- 1 Press the [Quit] button to exit the system.

Memo

Once the power is turned off, it takes a long time to start printing because the unit performs the bleed process upon the next startup.
If you only stop operation for several hours, keep the printhead suspended (stop mode) without turning off the power.

- 2 A dialog box appears stating "Quit the system?". Then, press the "Yes" button. The message: "Sys shutdown." appears on the screen. Then, the power is turned off.

Caution

- If the printhead is in the running mode, the power is turned off after the nozzle is capped. (The system does not shut down until the ongoing printing is completed. If an encoder is used, be careful.)
- Note that if the system is forcibly shut down without this process, data may be damaged.

Memo

- You can also turn off the power by holding down the standby switch on the operation panel.
- The Start timer setting feature (refer to "2-1. Various settings, Setting of the timer start" in the separate Instruction manual: "Operation/Maintenance") is convenient for startup.

To start up the system next time, turn ON the standby switch of the operation panel.

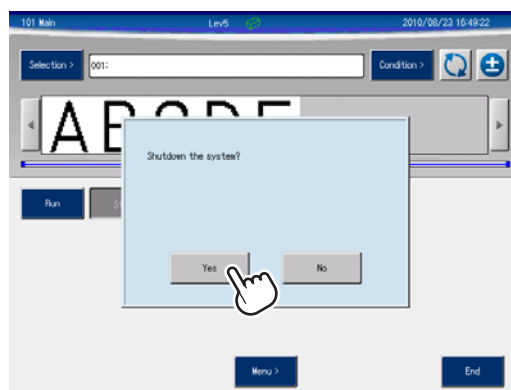
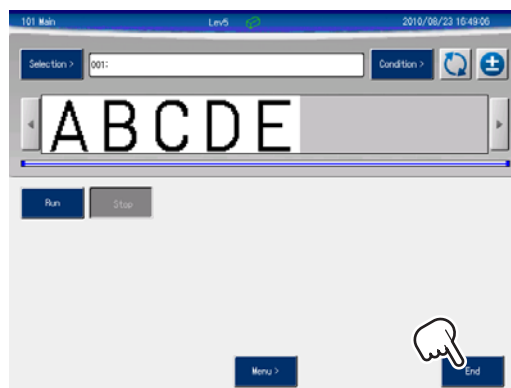



2 Operation screen

2-1 Precautions for the touch panel

This product is operated by making an entry or a selection with the touch panel.

Caution

Note that the following operations may damage the screen.

- Do not operate the unit by touching the screen with a sharp-pointed object (such as a pen tip and tweezers).
- Do not touch too hard on the screen.

2-2 Description of the main screen, the menu screen, and the icon buttons.

This section describes the main screen, the menu screen, and the icon buttons.

Main screen

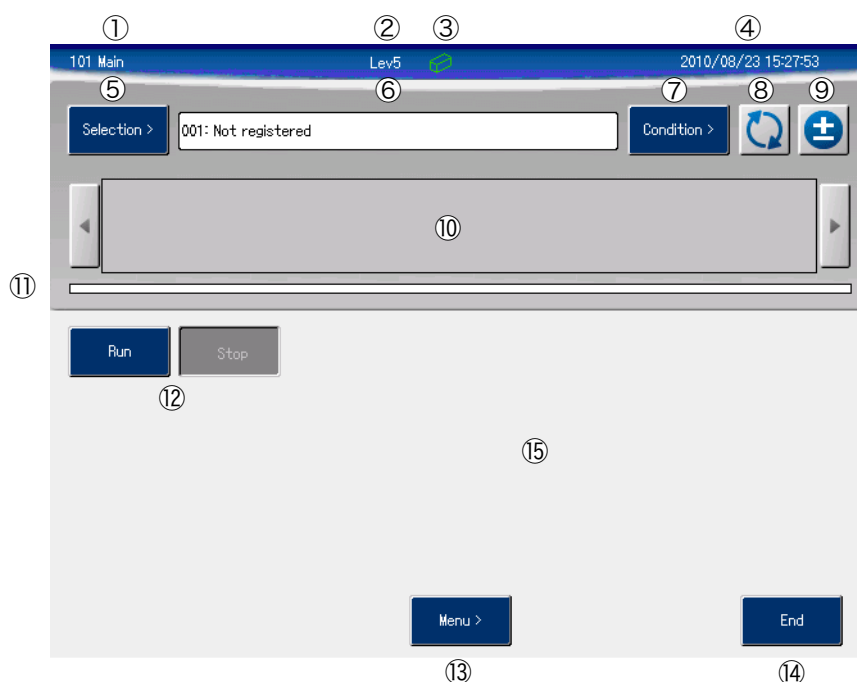

No.	Name	Description
1	Screen name	Indicates the name of the displayed screen.
2	Operation level	Indicates the current operation level.
3	Status icon	Indicates the current status. For details, refer to "Status icon" on page 45.
4	System clock	Indicates the date and time according to the system clock setting. For details, refer to "2-1. Various settings, Setting of the system clock" in the separate Instruction manual: "Operation/Maintenance."
5	[Select] button	Switches to the message selection screen. For details, refer to "1-3. Creating a message, Selecting a message" in the separate Instruction manual: "Operation/Maintenance."
6	Message comment window	Indicates a comment for a message.

No.	Name	Description
7	[Condition] button	Switches to the Condition screen. For details, refer to "1-4. Setting the printing conditions" in the separate Instruction manual: "Operation/Maintenance."
8	Refresh button	For details, refer to "Icon buttons" on page 43.
9	Zoom button	For details, refer to "Icon buttons" on page 43.
10	Message preview	Previews the content of the currently selected message data. * If an aspect ratio or an interval module is used, spaces in an image displayed in the "message preview" are different from those in the actual printing.
11	Scroll indicator	Indicates the position of the preview of the currently selected message data.
12	[Run]/[Stop] button	Switches the running status of the printhead.
13	[Menu] button	Switches to the menu screen.
14	[Quit] button	Performs the ending process to turn off the power.
15	User button display area	Indicates buttons set as user buttons. For details, refer to "2-1. Various settings, Setting of the screen operation, user button, and environment, Setting of the user button" in the separate Instruction manual: "Operation/Maintenance."

Menu screen

Memo



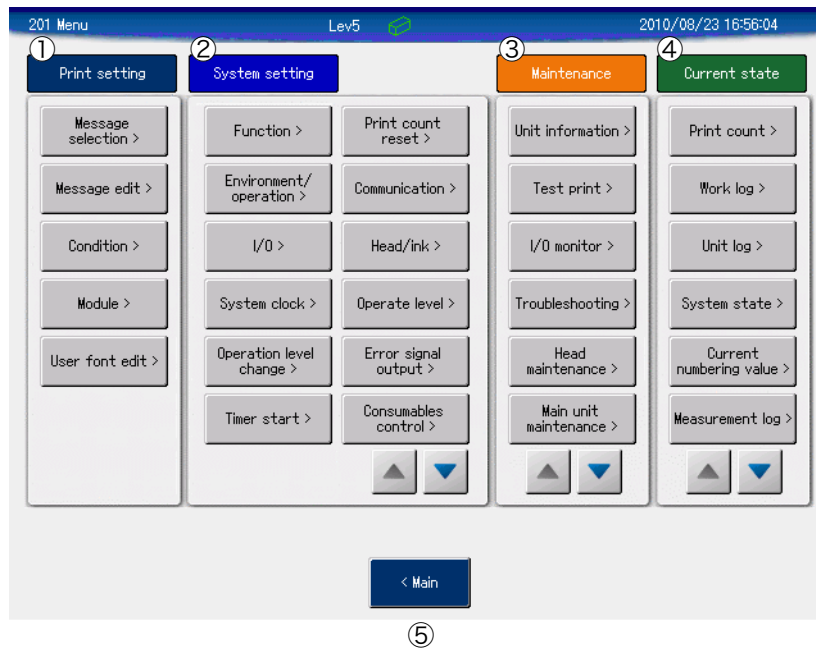















The number of buttons displayed on the menu screen and the number of setting items displayed on each setting screen can be customized depending on the user's application. The instruction manual describes the screen display using the "Full" option of the "Set all defaults collectively" setting. For details, refer to "2-1. Various settings, Setting of the function selection" in the separate Instruction manual: "Operation/Maintenance."







No.	Name	Description
1	"Print setting" area	Button area for setting the details of printing For details of each button, refer to "2-3. Screen transition" on page 46.
2	"System setting" area	Button area for setting the details of the system For details of each button, refer to "2-3. Screen transition" on page 46. (Some buttons are not displayed by default.)
3	"Maintenance" area	Button area for setting the details of maintenance For details of each button, refer to "2-3. Screen transition" on page 46. (Some buttons are not displayed by default.)
4	"Current state" area	Button area for controlling the current status For details of each button, refer to "2-3. Screen transition" on page 46. (Some buttons are not displayed by default.)
5	[Main] button	Switches to the main screen.

Icon buttons











Frequently used buttons are displayed as icons on each setting screen.

No.	Name	Description
	Confirmation button	Confirms settings and returns to the previous screen.
	Apply button	Confirms settings and does not return to the previous screen.
	Cancel button	Cancels settings and returns to the previous screen.
	Clear button	Clears display contents.
	Return button	Returns to the previous screen.
	Refresh button	Updates display contents.
	Zoom button	Zooms in or out displayed message contents.
	Right and left scroll buttons	Scrolls displayed message contents leftward or rightward.
	Item scroll buttons	Scrolls and displays hidden items.
	Cursor move buttons	Moves the selection cursor by one item.
		Moves the selection cursor by five items.
		Moves the selection cursor to the beginning or the end.
	Delete button	Deletes selected contents.
	Copy button	Copies and adds selected contents.
	Select/Edit button	Switches to the edit screen for a selected module or message.
	Text module select button	Switches to the registration/selection screen for a text module.
	Calendar module select button	Switches to the registration/selection screen for a calendar module.
	Numbering module select button	Switches to the registration/selection screen for a numbering module.
	Barcode module select button	Switches to the registration/selection screen for a barcode module.

No.	Name	Description
	2D code module select button	Switches to the registration/selection screen for a 2D code module.
	Bit image module select button	Switches to the selection screen for an bit image module.
	Interval module select button	Switches to the registration/selection screen for an interval module.
	Distance module select button	Switches to the registration/selection screen for a distance module.

Status icon

The status icons indicate the current status.

No.	Name	Description
	Printhead cover status icon	Indicates that the printhead is in the stop mode.
		Indicates that the printhead is in the running mode and can perform printing.
		Indicates that the printhead is in transition between the running mode and the stop mode.
		Indicates that the printhead cover is open.
		Indicate that maintenance is in progress.
	Head heating complete status icon	Indicates that the printhead heater completed the heating.
	Ink reservoir status icon	Indicates that the amount of ink is low (when the icon is blinking). Indicates that there is no ink (when the icon is lit).
	Consumables status icon	Indicates that it is time to replace a certain consumable.
	Solvent reservoir status icon	Indicates that the amount of solvent is low (when the icon is blinking). Indicates that there is no solvent (when the icon is lit).
	Ink viscosity status icon	Indicates that the viscosity of ink is lower than its appropriate value.
		Indicates that the viscosity of ink is higher than its appropriate value.

2-3 Screen transition

This section describes the transition of the operation screens.



Main screen



Menu screen



Print setting



Message selection



Msg edit (Select)



Msg edit (Edit)



Condition

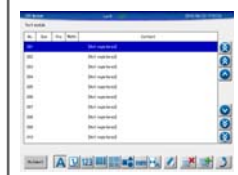

Module



Edit user-font

System setting



Function



Reset print counter



Environment



Communication



I/O



Head/ink



System clock



Operation level



Change operation level



Error signal output



Start timer



Consumables control



Alarm process

Maintenance

Current state

Unit information

Test printing

I/O monitor

Troubleshooting

Head maintenance

Main unit maintenance

Print counter

Work log

Unit log

System state

Current numbering value

Measurement log

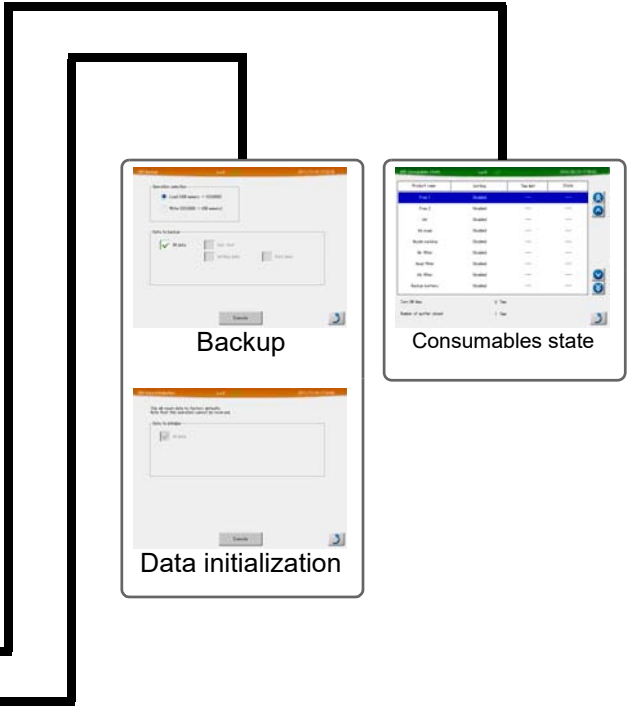

Memo

The number of buttons displayed on the menu screen and the number of setting items displayed on each setting screen can be customized depending on the user's application. The instruction manual describes the screen display using the "Full" option of the "Set all defaults collectively" setting. For details, refer to "2-1. Various settings, Setting of the function selection" in the separate Instruction manual: "Operation/Maintenance."

3 Ink and solvent

3-1 Compatibility of ink, solvent, and cleaning solution

There are a wide variety of ink types and colors available for this product so that it can be used for various applications. For the list of solvents and cleaning solutions compatible with each ink, refer to the "ink compatibility table."

3-2 Consumption of ink and solvent

Memo

Ink and solvent are volatile liquids. Therefore, the consumption depends on the installation environment of this product. Use the formula only as a guide.

Ink consumption

In this product, the ink consumption per 1 dot of ink is as follows.

Nozzle diameter	Ink consumption per 1 dot
40 μm	Approximately 3.7×10^{-7} ml
50 μm	Approximately 5.6×10^{-7} ml
60 μm	Approximately 8.6×10^{-7} ml
75 μm	Approximately 14×10^{-7} ml

In this product, the number of messages that can be printed per 1 ml of ink is as follows.

Nozzle diameter	Number of dots that can be printed per 1 ml
40 μm	Approximately 2.7 million dots
50 μm	Approximately 1.79 million dots
60 μm	Approximately 1.17 million dots
75 μm	Approximately 0.71 million dots

A formula for calculating the number of messages that can be printed per 1 ml of ink is as follows.

$$\text{Number of messages that can be printed} = \frac{\text{Number of dots that can be printed per 1 ml}}{\text{Total number of printing dots} \times \text{Density setting}}$$

- "Total number of printing dots" is displayed on the "Message selection" screen.

Solvent consumption

The consumption of solvent is proportional to the operation time when the gutter is open. The relationship between the room temperature and possible operation time is as follows.

Room temperature	Possible operation time per 1 L of solvent
Approximately 20 °C	Approximately 200 hours

* In the case of CN505 Black

3-3 Remaining amounts of ink and solvent

The remaining amounts of ink and solvent in their reservoirs are controlled in two alarm levels.

- Warning screen

If the level of ink or solvent (or both) falls below the required level (Dye type ink reservoir/Solvent reservoir : 150ml, Pigment type ink reservoir : 210ml, Magnetic stirrer type ink reservoir : 320ml), the warning screen appears, and the "Supply" LED on the operation panel lights up. For details of refilling, refer to "3-8. Maintenance of the main unit, Supplying the ink and solvent" in the separate Instruction manual: "Operation/Maintenance."



Caution

- When the "Supply" LED lights up and the buzzer sounds, immediately perform refilling. Printing stops when the system enters the Alarm process.
- Do not exceed "MAX LEVEL" attached on each reservoir during refilling. Otherwise, the liquid may overflow.
- We guarantee stable use of ink for this product within a prescribing range of usage environment and an expiration date. The expiration date is regulated according to sufficient verifications. When you use our ink for over the restriction on the use range, a performance degradation of this product, a decline in an ink function, and/or any trouble could be occurred. For these reasons, please make sure you will use our ink before the expiration date. Thank you for your understanding.
- For expiration date of ink or solvent, refer to description on bottle label.

Memo

Shake pigment ink before supplying it. If sediments cannot be removed, thoroughly stir them in the bottle using the supplied stirring rod.

- Alarm screen

If the remaining amount of ink or solvent in its reservoir has been used up without refilling on the warning screen, the Alarm screen appears. Then, the Alarm lamp on the operation panel lights up, and the buzzer sounds (continuous sound). For details of refilling, refer to "3-8. Maintenance of the main unit, Supplying the ink and solvent" in the separate Instruction manual: "Operation/Maintenance."

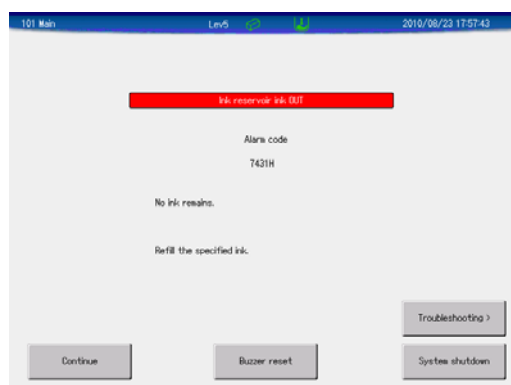

Viscosity measurement

Ink and solvent are blended in the equipment so that the viscosity is suitable for printing. A Zahn cup is used to measure the viscosity.

- Principles
With a Zahn cup, ink is supplied to the top of a cylindrical reservoir, and the time taken for ink to drop from a tiny hole at the bottom is measured to determine the viscosity.
- Operation

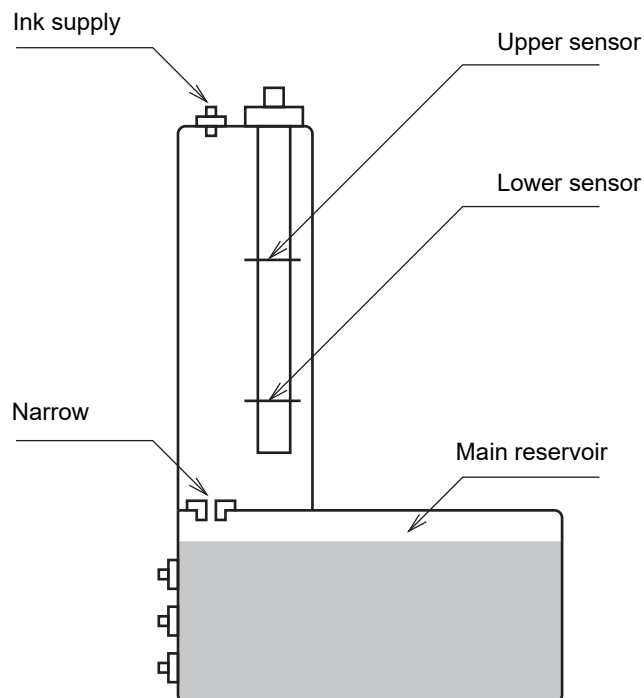

Status	Process
Normal operation	A circulating pump circulates and agitates ink.
Injection to the Zahn cup	After a lapse of a certain time from the end of the previous measurement, ink is supplied from the main reservoir to the Zahn cup. The amount of liquid reaches the upper sensor. (After that, the supply continues for a predetermined time.)
Start of measurement of the time taken to drop	The supply of ink to the Zahn cup is stopped. Ink drops from the narrow tube at the bottom to the main reservoir, and the amount of liquid in the Zahn cup starts to decrease. When the upper sensor switches from OFF to ON, measurement starts.
End of measurement of the time taken to drop	When the amount of liquid reaches the lower sensor, the time elapsed from the start of measurement is measured, and normal operation starts again. This measured time is used as the viscosity of ink for viscosity control.

Ink refilling operation in the equipment

Refilling operation starts when the liquid level sensor turns off. Based on the drop time measured by the Zahn cup and the intrinsic viscosity standard value of each ink, it is determined whether ink or solvent should be supplied.

Judgment of measurement result	Process	Status
Measured drop time < Viscosity standard value	Ink refilling	The drop speed is high because the viscosity is low. Therefore, ink is supplied and solvent is volatilize, wait to increase the viscosity.
Measured drop time \geq Viscosity standard value	Solvent refilling	The drop speed is low because the viscosity is high. Therefore, solvent is supplied to decrease the viscosity.

4 Specifications

4-1 Product specifications

Model	Dye standard machine	Pigment machine (not equipped with magnetic stirrer)	Pigment machine (equipped with magnetic stirrer)	Pigment machine (equipped with magnetic stirrer & rocker solenoid valve)	Egg machine
Model name Type	CCS3100-D CCS3100D	CCS3100-P CCS3100P	CCS3100-PS CCS3100PS	CCS3100-PSV CCS3100PSV	CCS3100-EG CCS3100E
Print method	Continuous system (charge control system)				
Compatible ink	Dye ink, and some of pigment ink	Pigment ink	Pigment ink (specified to use magnetic stirrer)	Pigment ink (specified to use magnetic stirrer & rocker solenoid valve)	Ink for eggs
For details, refer to "Ink compatibility table".					
Dust- and water-proof	IP65				
CE marking	Compliant				
RoHS directive	Compliant				
Screen size	10.4" color LCD / touch panel				
Operation panel cable length	3.5 m				
Compatible nozzle	40 μm / 50 μm / 60 μm / 75 μm * For details, refer to "Ink compatibility table".				
Character height	Approximately 0.8 to 5 mm (40 μm nozzle) Approximately 1 to 10 mm (50 μm nozzle) Approximately 2 to 10 mm (60 μm, 75 μm nozzle) * Depends on the distance between printhead and a workpiece, the print speed, and the ambient temperature.				
Maximum print speed	2,133 ~ 3,666 characters/second * The maximum print speed in the case of using 5x5 dots font and setting the character spacing 1 dot. * For details, refer to "Ink compatibility table".				
Character type	Alphabetical characters (uppercase/lowercase), numerical characters, symbols, Hiragana characters, Katakana characters, Kanji characters (JIS 1st and 2nd standard), Simplified Chinese characters (G B2312), user-defined characters				
Number of printing lines and number of dots	e.g. 1 to 6 lines, 1 to 5 lines: 5 x 5, 5 x N dots 1 to 4 lines: 7 x 5, 7 x 8, 7 x N dots 1 to 3 lines: 9 x 7, 9 x 9, 10 x 8, 12 x 10 dots 1 to 2 lines: 16 x 12, 16 x 16 dots 1 line: 24 x 18, 24 x 24, 32 x 24, 32 x 32 dots * The number of printing lines in the case of placing the character transversely. * The font matrix is described as "vertical x horizontal". * 5 x N and 7 x N are proportional fonts.				
Number of characters registered for a message	Up to 4096 characters				
Number of messages registered	Up to 999 messages				
Date/time (use-by date) printing function	Function of assignment of Christian year, Japanese-style year, date, day of week, time (12/24-hour format), Julian date, serial week number in a year, early/middle/late part of month (variable period setting), AM/PM, shift code, and character assignment function (year, month, day, hour, minute, second, and day of week) to up to 4 to 15 other characters				
Numbering function	Up to 10 digits, initial value setting, up/down, carry (1 count can be set at 1 to 9999 workpieces), zero suppress function (high-order zero is replaced with a space, or left-justified), numbering character assignment function (numbering can be assigned to other characters than numerical characters), base setting (binary number to base 36 number), separable (a character can be inserted between numerical characters)				
Distance printing function	Up to 10 digits, separable (a character can be inserted between numerical characters)				
Barcode printing function	ITF, Code39, NW7, EAN, Code128, UPC, Code93				
2D code printing function	QR code and Data matrix				
Kana-kanji conversion	Available				

Model	Dye standard machine	Pigment machine (not equipped with magnetic stirrer)	Pigment machine (equipped with magnetic stirrer)	Pigment machine (equipped with magnetic stirrer & rocker solenoid valve)	Egg machine
Model name Type	CCS3100-D CCS3100D	CCS3100-P CCS3100P	CCS3100-PS CCS3100PS	CCS3100-PSV CCS3100PSV	CCS3100-EG CCS3100E
External connection	I/O, signal lamp, RS-232C, LAN, encoder, UPS, USB media				
Data entry	Touch panel, RS-232C communication, Ethernet				
Communications function	RS-232C 1CH, up to 115,200 bps Ethernet				
Head cable length	3.5 m				
Dry air source	Compatible tube outside diameter: 6 mm or 8 mm in diameter Air source pressure: 0.8 MPa or less Air flow: 70 L/min or less (pigment machine equipped with magnetic stirrer) 10 L/min or less (excluding pigment machine equipped with magnetic stirrer) * Air ventilation set included				
Outside dimensions (Width x Depth x Height)	Main unit: 400 mm x 307 mm x 548 mm (excluding protrusions) Printhead: Φ 49.2 mm x 197 mm				
Operating environment (temperature, humidity)	0 to 40 °C 10 to 85% (non-condensing) * For details, refer to "Ink compatibility table"				
Power	100-240V, 50/60Hz, 0.9-0.5A				
Weight	25 kg				
Grounding	Class D ground				

Character/printing specifications

■ Standard font

The standard fonts installed in this product are as follows.

Character type	32x32	32x24	24x24	24x18	16x16	16x12	12x10
Alphanumeric characters and symbols	Gothic Mincho *1	Original	Gothic Mincho *1	Original	Gothic Mincho *1	Original	Original
Hiragana characters	Gothic Mincho *1	Original	Gothic Mincho *1	Original	Original *1	Original	Original
Katakana characters	Gothic Mincho *1	Original	Gothic Mincho *1	Original	Original *1	Original	Original
Kanji characters	Gothic Mincho	Original	Gothic Mincho	Original *2	Original	Original *2	Original *3

Character type	10x8	9x9	9x7	7x8	7x5, 7xN	5x5, 5xN
Alphanumeric characters and symbols	Original	Original	Original	Original	Original	Original
Hiragana characters	Original *1	Original	Original	Original	Original *4	- *5
Katakana characters	Original *1	Original	Original	Original	Original	Original *4
Kanji characters	Original *3	Original *2	Original *3	Original *3	- *5	- *5

Original: An original typeface for CCS3100 is registered.

*1 A character style can be selected from [Standard/Bold] as an installation option.

*2 Font data is registered, but it is impractical except "JIS 1st standard."

*3 Font data is registered, but it is impractical except "Specific char"

*4 Impractical font data is partly included.

*5 Font data is registered, but it is impractical.

Specific char (for English)	I	II	III	IV	V	VI	VII	VIII	IX	X	←	↑	→	↓	①	②	③	④	⑤	⑥	⑦	⑧	⑨	⑩	⑪	⑫	⑬	⑭
	⑮	⑯	⑰	⑱	⑲	⑲																						

■ Messages

Up to 999 messages (printing contents) can be registered.

Type of module	General description of module
Text module	String of normal characters such as alphanumeric characters, symbols, Kanji characters, and Katakana characters
Calendar module	Date/time such as a date of manufacture and a use-by date
Numbering module	Automatic carry (borrow) printing
Barcode module	Barcode printing
2D code module	Printing 2D code such as QR code and Data matrix
Bit image module	User-created graphic data
Interval module	Space between modules
Distance module	Printing of a distance at a constant pitch

■ Multiple lines printing

In the case of using the module of placing the character transversely, multiple lines printing can be performed. And multiple lines printing can be performed even if fonts with different numbers of dots are mixed. Multiple lines printing allows the use of various formats based on the settings of Condition (vertical dots, font size, and arrangement). When a message is created, the font positions can be specified by the number of lines or by making an arbitrary setting.

Image sample for the number of lines

The number of lines can be specified, up to 6 lines, and the print positions of the 2nd and subsequent lines are determined depending on the number of vertical dots. Images for multiple lines with different numbers of vertical dots in the case of fixed width fonts are as follows.

Number of vertical dots: 36

Lines	Print position	Font sizes that can be registered	Image
1	1st line (0th dot)	32x32 or less (all character directions)	
2	1st line (0th dot) 2nd line (18th dot)	24x18 (horizontal), 16x16 or less (all character directions)	
3	1st line (0th dot) 2nd line (12th dot) 3rd line (24th dot)	16x12 (horizontal), 12x10 or less (all character directions)	
4	1st line (0th dot) 2nd line (9th dot) 3rd line (18th dot) 4th line (27th dot)	10x8 (horizontal), 7xN (vertical), 9x9 or less (all character directions)	
5	1st line (0th dot) 2nd line (7th dot) 3rd line (14th dot) 4th line (21th dot) 5th line (28th dot)	9x7 (horizontal), 7xN (vertical), 7x8 (vertical), 5xN (vertical), 7x5 or less (all character directions)	
6	1st line (0th dot) 2nd line (6th dot) 3rd line (12th dot) 4th line (18th dot) 5th line (24th dot) 6th line (30th dot)	7x5 (horizontal), 5xN (vertical), 5x5 (all character directions)	

4

Specifications

Number of vertical dots: 32

Lines	Print position	Font sizes that can be registered	Image
1	1st line (0th dot)	32x32 or less (all character directions)	
2	1st line (0th dot) 2nd line (16th dot)	16x16 or less (all character directions)	
3	1st line (0th dot) 2nd line (10th dot) 3rd line (20th dot)	12x10 (horizontal), 10x8 or less (all character directions)	
4	1st line (0th dot) 2nd line (8th dot) 3rd line (16th dot) 4th line (24th dot)	10x8 (horizontal), 9x7 (horizontal), 7xN (vertical), 7x8 or less (all character directions)	
5	1st line (0th dot) 2nd line (6th dot) 3rd line (12th dot) 4th line (18th dot) 5th line (24th dot)	7x5 (horizontal), 5xN (vertical), 5x5 (all character directions)	
6	1st line (0th dot) 2nd line (5th dot) 3rd line (10th dot) 4th line (15th dot) 5th line (20th dot) 6th line (25th dot)	7x5 (horizontal), 5xN (vertical), 5x5 (all character directions)	

Number of vertical dots: 28

Lines	Print position	Font sizes that can be registered	Image
1	1st line (0th dot)	32x24 (horizontal), 24x24 or less (all character directions)	
2	1st line (0th dot) 2nd line (14th dot)	16x12 (horizontal), 12x10 or less (all character directions)	
3	1st line (0th dot) 2nd line (9th dot) 3rd line (18th dot)	10x8 (horizontal), 7xN (vertical), 9x9 or less (all character directions)	
4	1st line (0th dot) 2nd line (7th dot) 3rd line (14th dot) 4th line (21th dot)	9x7 (horizontal), 7xN (vertical), 7x8 (vertical), 5xN (vertical), 7x5 or less (all character directions)	
5	1st line (0th dot) 2nd line (5th dot) 3rd line (10th dot) 4th line (15th dot) 5th line (20th dot)	7x5 (horizontal), 5xN (vertical), 5x5 (all character directions)	

Number of vertical dots: 26

Lines	Print position	Font sizes that can be registered	Image
1	1st line (0th dot)	32x24 (horizontal), 24x24 or less (all character directions)	
2	1st line (0th dot) 2nd line (13th dot)	16x12 (horizontal), 12x10 or less (all character directions)	
3	1st line (0th dot) 2nd line (8th dot) 3rd line (16th dot)	10x8 (horizontal), 9x7 (horizontal), 7xN (vertical), 7x8 or less (all character directions)	
4	1st line (0th dot) 2nd line (6th dot) 3rd line (12th dot) 4th line (18th dot)	7x5 (horizontal), 5xN (vertical), 5x5 (all character directions)	
5	1st line (0th dot) 2nd line (5th dot) 3rd line (10th dot) 4th line (15th dot) 5th line (20th dot)	7x5 (horizontal), 5xN (vertical), 5x5 (all character directions)	

Number of vertical dots: 24

Lines	Print position	Font sizes that can be registered	Image
1	1st line (0th dot)	32x24 (horizontal), 24x24 or less (all character directions)	
2	1st line (0th dot) 2nd line (12th dot)	16x12 (horizontal), 12x10 or less (all character directions)	
3	1st line (0th dot) 2nd line (8th dot) 3rd line (16th dot)	10x8 (horizontal), 9x7 (horizontal), 7xN (vertical), 7x8 or less (all character directions)	
4	1st line (0th dot) 2nd line (6th dot) 3rd line (12th dot) 4th line (18th dot)	7x5 (horizontal), 5xN (vertical), 5x5 (all character directions)	

Number of vertical dots: 22

Lines	Print position	Font sizes that can be registered	Image
1	1st line (0th dot)	24x18 (horizontal), 16x16 or less (all character directions)	
2	1st line (0th dot) 2nd line (11th dot)	12x10 (horizontal), 10x8 or less (all character directions)	
3	1st line (0th dot) 2nd line (7th dot) 3rd line (14th dot)	9x7 (horizontal), 7xN (vertical), 7x8 (vertical), 5xN (vertical), 7x5 or less (all character directions)	
4	1st line (0th dot) 2nd line (5th dot) 3rd line (10th dot) 4th line (15th dot)	7x5 (horizontal), 5xN (vertical), 5x5 (all character directions)	

Number of vertical dots: 20

Lines	Print position	Font sizes that can be registered	Image
1	1st line (0th dot)	24x18 (horizontal), 16x16 or less (all character directions)	
2	1st line (0th dot) 2nd line (10th dot)	12x10 (horizontal), 10x8 or less (all character directions)	
3	1st line (0th dot) 2nd line (6th dot) 3rd line (12th dot)	7x5 (horizontal), 5xN (vertical), 5x5 (all character directions)	
4	1st line (0th dot) 2nd line (5th dot) 3rd line (10th dot) 4th line (15th dot)	7x5 (horizontal), 5xN (vertical), 5x5 (all character directions)	

Number of vertical dots: 16

Lines	Print position	Font sizes that can be registered	Image
1	1st line (0th dot)	16x16 or less (all character directions)	
2	1st line (0th dot) 2nd line (8th dot)	10x8 (horizontal), 9x7 (horizontal), 7xN (vertical), 7x8 or less (all character directions)	
3	1st line (0th dot) 2nd line (5th dot) 3rd line (10th dot)	7x5 (horizontal), 5xN (vertical), 5x5 (all character directions)	

Number of vertical dots: 15

Lines	Print position	Font sizes that can be registered	Image
1	1st line (0th dot)	16x16 or less (all character directions)	
2	1st line (0th dot) 2nd line (8th dot)	9x7 (horizontal), 7xN (vertical), 7x8 (vertical), 5xN (vertical), 7x5 or less (all character directions)	
3	1st line (0th dot) 2nd line (5th dot) 3rd line (10th dot)	7x5 (horizontal), 5xN (vertical), 5x5 (all character directions)	

Number of vertical dots: 12

Lines	Print position	Font sizes that can be registered	Image
1	1st line (0th dot)	16x12 (horizontal), 12x10 or less (all character directions)	
2	1st line (0th dot) 2nd line (6th dot)	7x5 (horizontal), 5xN (vertical), 5x5 (all character directions)	

Number of vertical dots: 11

Lines	Print position	Font sizes that can be registered	Image
1	1st line (0th dot)	12x10 (horizontal), 10x8 or less (all character directions)	
2	1st line (0th dot) 2nd line (6th dot)	7x5 (horizontal), 5xN (vertical), 5x5 (all character directions)	

Number of vertical dots: 10

Lines	Print position	Font sizes that can be registered	Image
1	1st line (0th dot)	12x10 (horizontal), 10x8 or less (all character directions)	
2	1st line (0th dot) 2nd line (5th dot)	7x5 (horizontal), 5xN (vertical), 5x5 (all character directions)	

Number of vertical dots: 9, 7, 5

Vertical dots	Print position	Font sizes that can be registered	Image
5	1st line (0th dot)	7x5 (horizontal), 5xN (vertical), 5x5 (all character directions)	
7	1st line (0th dot)	9x7 (horizontal), 7xN (vertical), 7x8 (vertical), 5xN (vertical), 7x5 or less (all character directions)	
9	1st line (0th dot)	10x8 (horizontal), 7xN (vertical), 9x9 or less (all character directions)	

■ Samples for arbitrary print position settings

Limits of positioning the lowest dot of each font dot in the case of fixed width fonts.

Vertical dots	Character direction	32x32	32x24	24x24	24x18	16x16	16x12	12x10	10x8
36	Vertical	0-4	0-4	0-12	0-12	0-20	0-20	0-24	0-26
	Horizontal	0-4	0-12	0-12	0-18	0-20	0-24	0-26	0-28
32	Vertical	0	0	0-8	0-8	0-16	0-16	0-20	0-22
	Horizontal	0	0-8	0-8	0-14	0-16	0-20	0-22	0-24
28	Vertical	-	-	0-4	0-4	0-12	0-12	0-16	0-18
	Horizontal	-	0-4	0-4	0-10	0-12	0-16	0-18	0-20
26	Vertical	-	-	0-2	0-2	0-10	0-10	0-14	0-16
	Horizontal	-	0-2	0-2	0-8	0-10	0-14	0-16	0-18
24	Vertical	-	-	0	0	0-8	0-8	0-12	0-14
	Horizontal	-	0	0	0-6	0-8	0-12	0-14	0-16
22	Vertical	-	-	-	-	0-6	0-6	0-10	0-12
	Horizontal	-	-	-	0-4	0-6	0-10	0-12	0-14
20	Vertical	-	-	-	-	0-4	0-4	0-8	0-10
	Horizontal	-	-	-	0-2	0-4	0-8	0-10	0-12
16	Vertical	-	-	-	-	0	0	0-4	0-6
	Horizontal	-	-	-	-	0	0-4	0-6	0-8
15	Vertical	-	-	-	-	-	-	0-3	0-5
	Horizontal	-	-	-	-	-	0-3	0-5	0-7
12	Vertical	-	-	-	-	-	-	0	0-2
	Horizontal	-	-	-	-	-	0	0-2	0-4
11	Vertical	-	-	-	-	-	-	-	0-1
	Horizontal	-	-	-	-	-	-	0-1	0-3
10	Vertical	-	-	-	-	-	-	-	0
	Horizontal	-	-	-	-	-	-	0	0-2
9	Vertical	-	-	-	-	-	-	-	-
	Horizontal	-	-	-	-	-	-	-	0-1
7	Vertical	-	-	-	-	-	-	-	-
	Horizontal	-	-	-	-	-	-	-	-
5	Vertical	-	-	-	-	-	-	-	-
	Horizontal	-	-	-	-	-	-	-	-

Vertical dots	Character direction	9x9	9x7	7xN	7x8	7x5	5xN	5x5
36	Vertical	0-27	0-27	0-29	0-29	0-29	0-31	0-31
	Horizontal	0-27	0-29	0-26	0-28	0-31	0-28	0-31
32	Vertical	0-23	0-23	0-25	0-25	0-25	0-27	0-27
	Horizontal	0-23	0-25	0-22	0-24	0-27	0-24	0-27
28	Vertical	0-19	0-19	0-21	0-21	0-21	0-23	0-23
	Horizontal	0-19	0-21	0-18	0-20	0-23	0-20	0-23
26	Vertical	0-17	0-17	0-19	0-19	0-19	0-21	0-21
	Horizontal	0-17	0-19	0-16	0-18	0-21	0-18	0-21
24	Vertical	0-15	0-15	0-17	0-17	0-17	0-19	0-19
	Horizontal	0-15	0-17	0-14	0-16	0-19	0-16	0-19
22	Vertical	0-13	0-13	0-15	0-15	0-15	0-17	0-17
	Horizontal	0-13	0-15	0-12	0-14	0-17	0-14	0-17
20	Vertical	0-11	0-11	0-13	0-13	0-13	0-15	0-15
	Horizontal	0-11	0-13	0-10	0-12	0-15	0-12	0-15
16	Vertical	0-7	0-7	0-9	0-9	0-9	0-11	0-11
	Horizontal	0-7	0-9	0-6	0-8	0-11	0-8	0-11
15	Vertical	0-6	0-6	0-8	0-8	0-8	0-10	0-10
	Horizontal	0-6	0-8	0-5	0-7	0-10	0-7	0-10
12	Vertical	0-3	0-3	0-5	0-5	0-5	0-7	0-7
	Horizontal	0-3	0-5	0-2	0-4	0-7	0-4	0-7
11	Vertical	0-2	0-2	0-4	0-4	0-4	0-6	0-6
	Horizontal	0-2	0-4	0-1	0-3	0-6	0-3	0-6
10	Vertical	0-1	0-1	0-3	0-3	0-3	0-5	0-5
	Horizontal	0-1	0-3	0	0-2	0-5	0-2	0-5
9	Vertical	0	0	0-2	0-2	0-2	0-4	0-4
	Horizontal	0	0-2	-	0-1	0-4	0-1	0-4
7	Vertical	-	-	0	0	0	0-2	0-2
	Horizontal	-	0	-	-	0-2	-	0-2
5	Vertical	-	-	-	-	-	0	0
	Horizontal	-	-	-	-	0	-	0

5 Dimensional outline drawing

5-1 Main unit

Unit: [mm]

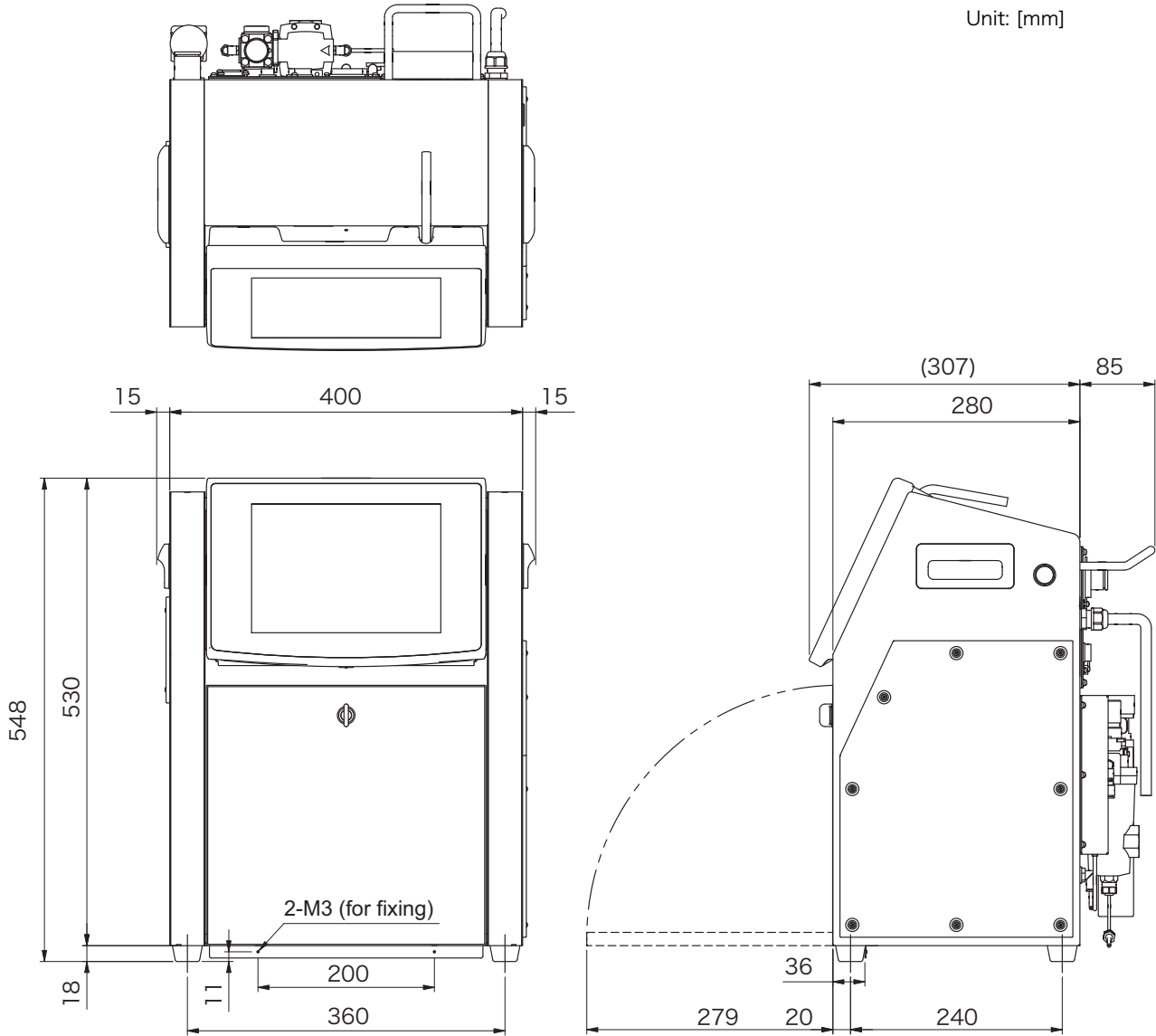

5-2 Printhead

Unit: [mm]

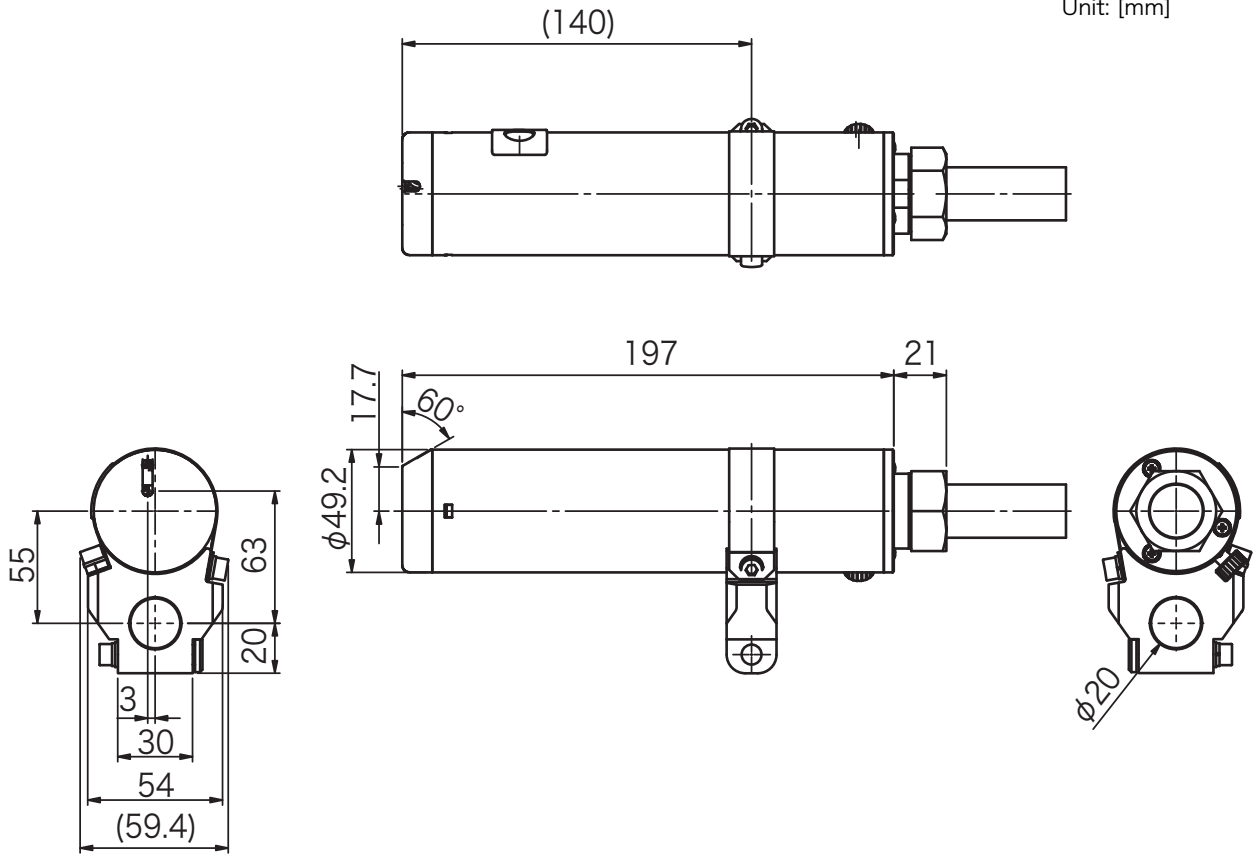

5-3 Operation panel

Unit: [mm]

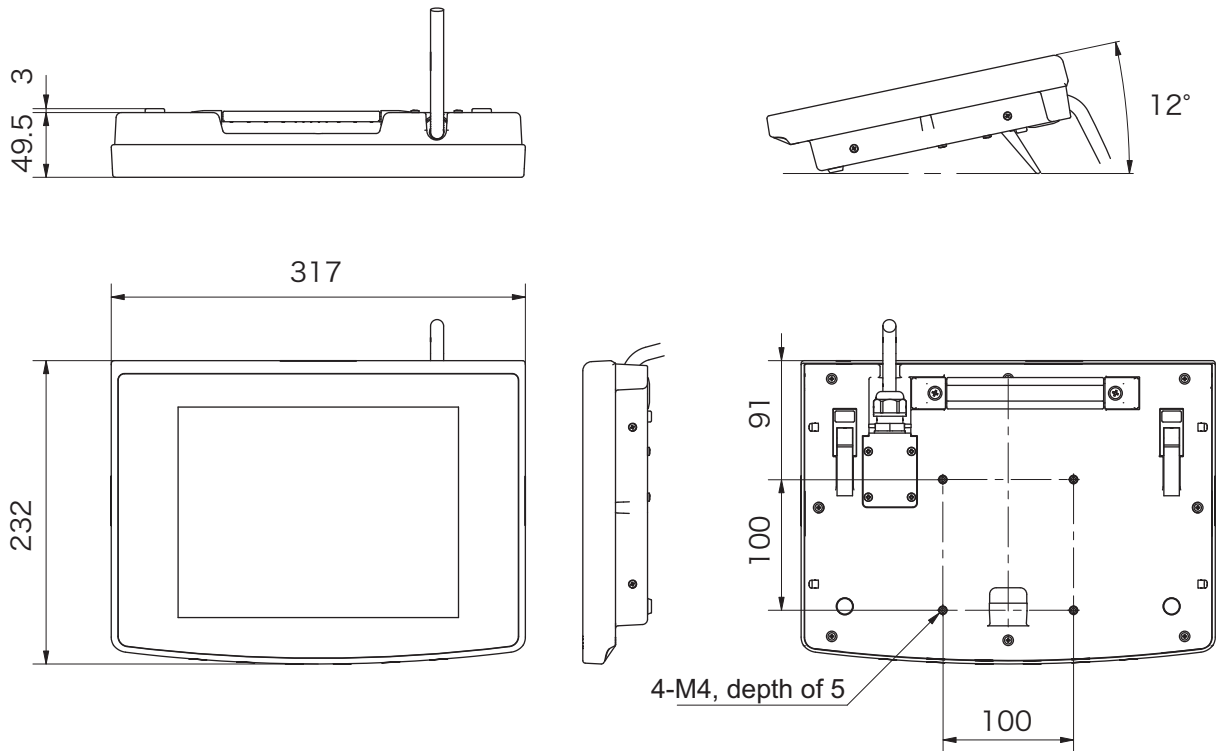



Kishu Giken Kogyo Co., Ltd.

466 Nunohiki, Wakayama-shi, Japan 641-0015
<https://www.kishugiken.co.jp>



TEC2785ZAD (February, 2024)